

DS/RS MACO-NET Firmware Update Kit 71-1145-xx0 (V1.01)

	Yes	No
Changes to Wonderware CSV Files		X
Changes to Concept CSV Files		X
Changes to Modfile		X



WARNING:

Hazardous extraneous voltage capable of causing severe injury or death may exist between sensor leads and ground. Disconnecting the instrument power may not remove this voltage. Measure for the presence of voltage between each sensor lead and ground before servicing. Do NOT place power wiring in the same conduit or wiring trough with sensor wiring.

NOTICE:

Class 2 Wiring must be separated a minimum of 1/4 inch from any Class 1 conductors.

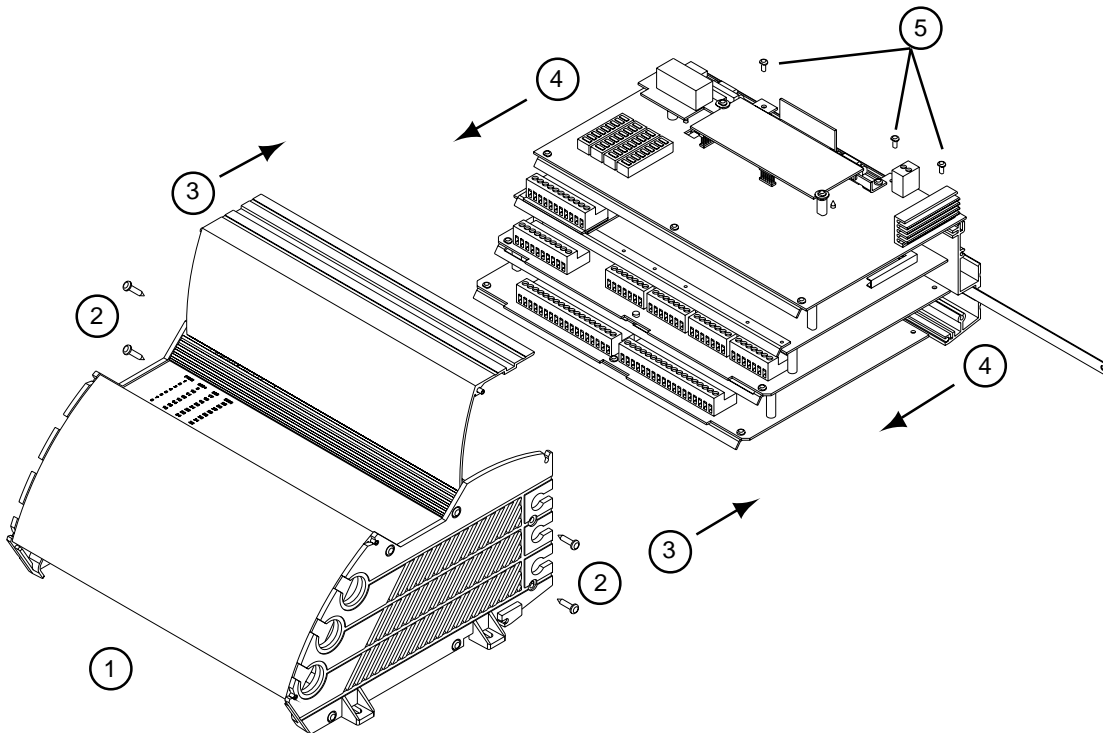

Attention:

Observe proper ESD precautions! Place the ASB assembly on an ESD mat and attach a wrist strap to the ground strap on the ASB.

1. Remove all field wiring connectors from the PCBs.
2. Remove the 2 screws from each side of the ASB.
3. Carefully slide the entire assembly out of the enclosure.
4. Boards in the bottom 3 slots can be removed by carefully pulling them forward off the motherboard connectors.
5. The Data Handler assembly is held in place by 3 screws.

Figure 1. Installing and Removing Boards in an ASB

6. On the A-60134 data handler, the communications board and battery are held in place by 3 screws and the processor board is held in place by 2 screws.

7. On the A-60149 data handler, the communications board is held in place by 4 screws and the processor board (if present) is held in place by 2 screws and a threaded bracket. The Anybus board (if present) is held in place by 3 screws.

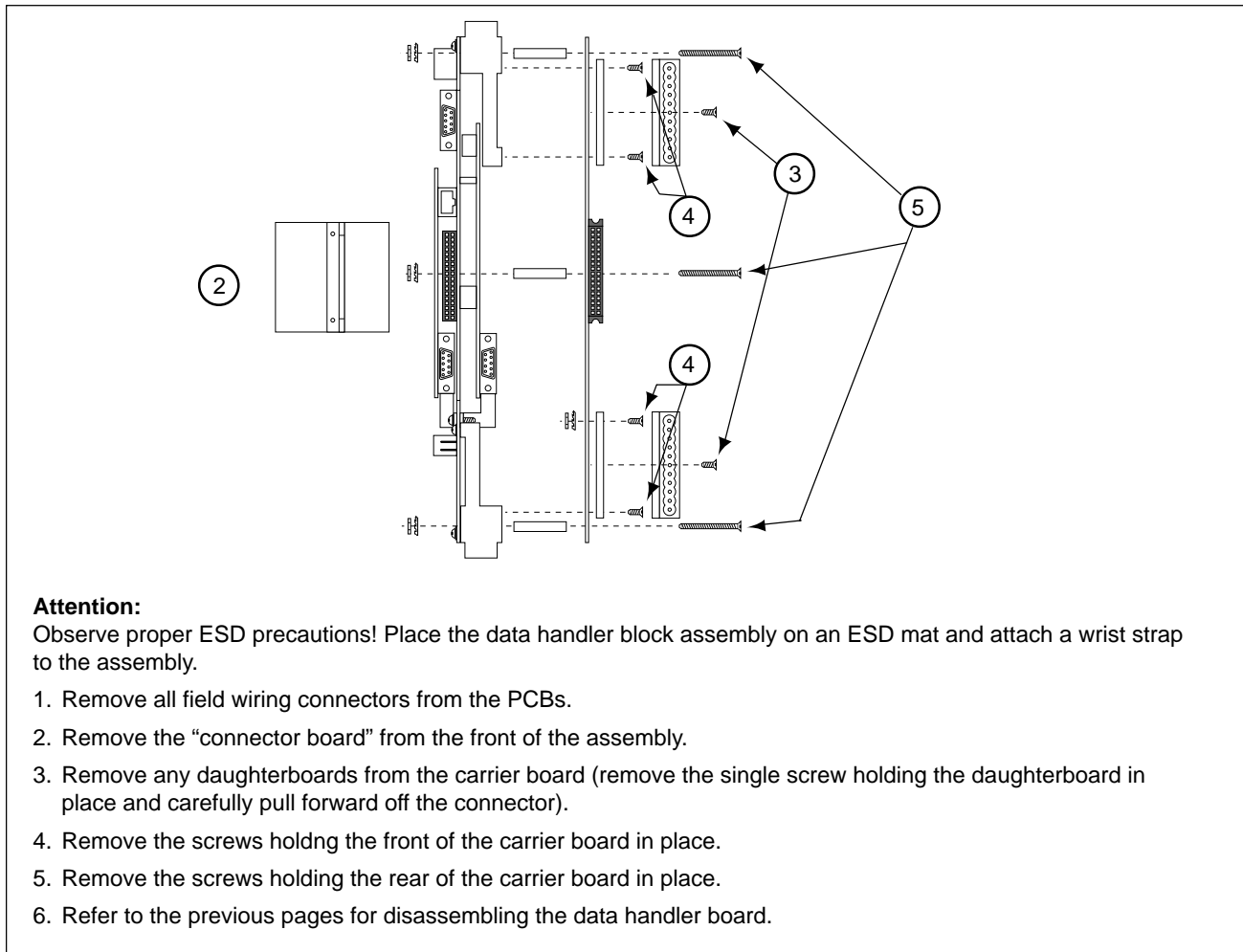
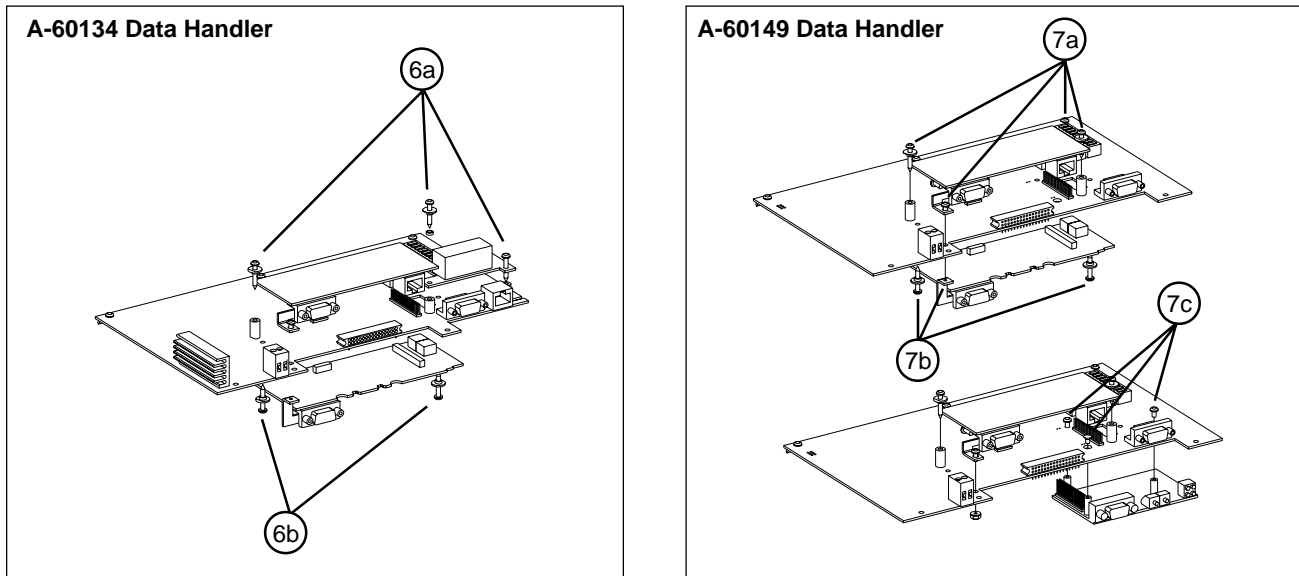

Attention:

Observe proper ESD precautions! Place the data handler block assembly on an ESD mat and attach a wrist strap to the assembly.

1. Remove all field wiring connectors from the PCBs.
2. Remove the "connector board" from the front of the assembly.
3. Remove any daughterboards from the carrier board (remove the single screw holding the daughterboard in place and carefully pull forward off the connector).
4. Remove the screws holding the front of the carrier board in place.
5. Remove the screws holding the rear of the carrier board in place.
6. Refer to the previous pages for disassembling the data handler board.

Figure 2. Disassembling the Data Handler Block in an RS

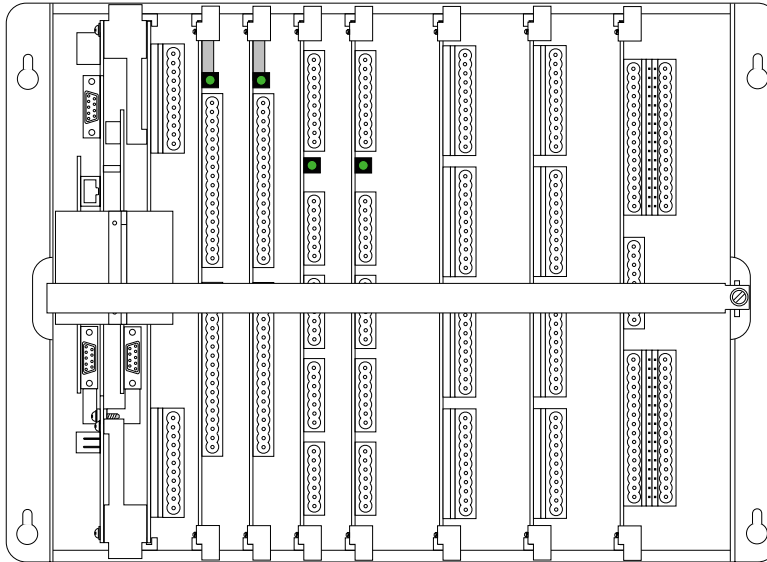

Attention:

Observe proper ESD precautions!

1. Power down the system.
2. Remove the “retaining bar” (or front cover) from the controller.
3. Remove the board from the controller.
4. Remove and replace the EPROM.
5. Reinstall the board.
6. Replace the retaining bar or front cover.
7. Apply power to the system.

Figure 3. Removing boards from a Rack System

Attention:

Observe proper ESD precautions! Place the board assembly on an ESD mat and attach a wrist strap to the ESD mat.

1. Remove the EPROM from "U1" using the extraction tool from kit 71-873.
2. Install the new EPROM labeled "SN-144 101-01 5600H" into "U1" being careful to follow the orientation indentation of the device.

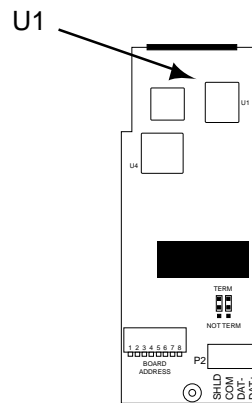

Figure 4. MACO-NET Card A-60187

MACO-NET Firmware Version 1.01:

This is the first release of the MACO-NET firmware.

This firmware requires that your DS/RS system use Data Handler firmware V3.01 (or later).



Barber-Colman Company / Eurotherm Controls, Inc.

741-F Miller Drive, Leesburg VA, 20175

Phone: 703-443-0000

Fax: 703-669-1300

<http://www.barber-colman.com> <http://www.eurotherm.com>

An Invensys Company

Copyright © Barber-Colman Company 2002