



170.IU0.XKC.0C1 05-02



USER MANUAL

PKC  
MKC



Xkc-01-C0.P65

2

5/29/02, 11:58 AM

## INDEX

MOUNTING REQUIREMENTS .....	1	ERROR MESSAGES .....	97
OUTLINE AND CUT OUT DIMENSIONS .....	2	GENERAL INFORMATIONS .....	103
CONNECTION DIAGRAMS .....	4	MAINTENANCE .....	112
PRELIMINARY HARDWARE SETTINGS .....	17	DEFAULT PARAMETERS .....	A.1
SECURITY CODE SETTING MODE .....	22	ALPHANUMERIC INDEX OF THE	
RUN TIME AND CONFIGURATION MODE .....	25	DISPLAY INDICATION .....	B.1
General notes about graphic symbols .....	25	CODING .....	B.7
Keyboard description .....	25		
CONFIGURATION MODE .....	27		
RUN TIME MODE .....	62		
Display function .....	62		
Indicators .....	64		
Bargraph description .....	65		
OUT failure detection function (OFD) .....	66		
Direct access to the set point .....	66		
Manual function .....	67		
Serial link .....	68		
Lamp test .....	69		
SMART function .....	69		
Hold function .....	70		
Parameter protection .....	70		
RUN TIME PARAMETER MODIFICATION .....	71		



Xkc-01-C0.P65

4

5/29/02, 11:58 AM

## MOUNTING REQUIREMENTS

Select a location, for instrument mounting, where minimum vibrations are present and the ambient temperature is within 0 and 50 °C (32 and 122 °F).

The instrument can be mounted on a panel up to 15 mm thick with a cutout of 92 x 45 mm (PKC) or 92 x 92 (MKC).

For outline and cutout dimensions refer to Fig. 2. The surface texture of the panel must be better than 6,3 µmm.

The instrument is shipped with rubber panel gasket (50 to 60 Sh).

To assure the IP65 and NEMA 4 protection, insert the panel gasket between the instrument and the panel as shown in fig. 1.

While holding the instrument against the panel proceed as follows:

- 1) insert the gasket in the instrument case;
- 2) insert the instrument in the panel cutout;
- 3) pushing the instrument against the panel;
- 4) insert the mounting brackets as shown in fig. 1;
- 5) with a screwdriver, turn the screws with a torque between 0.3 and 0.4 Nm.

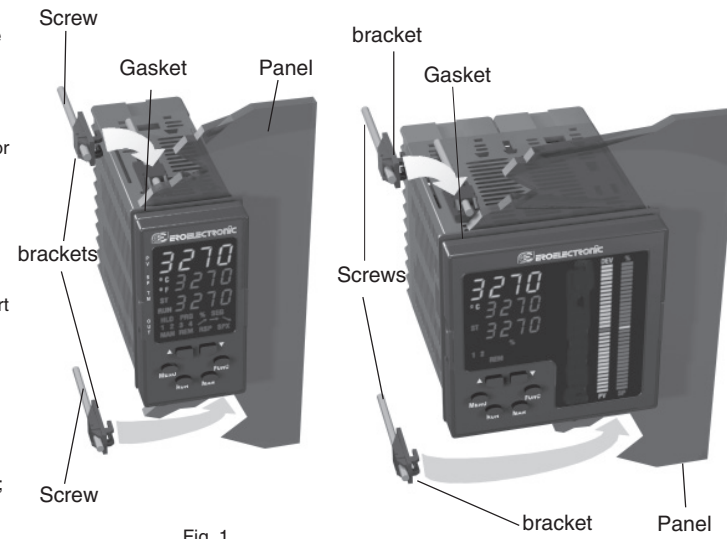

**OUTLINE AND CUT OUT DIMENSIONS**

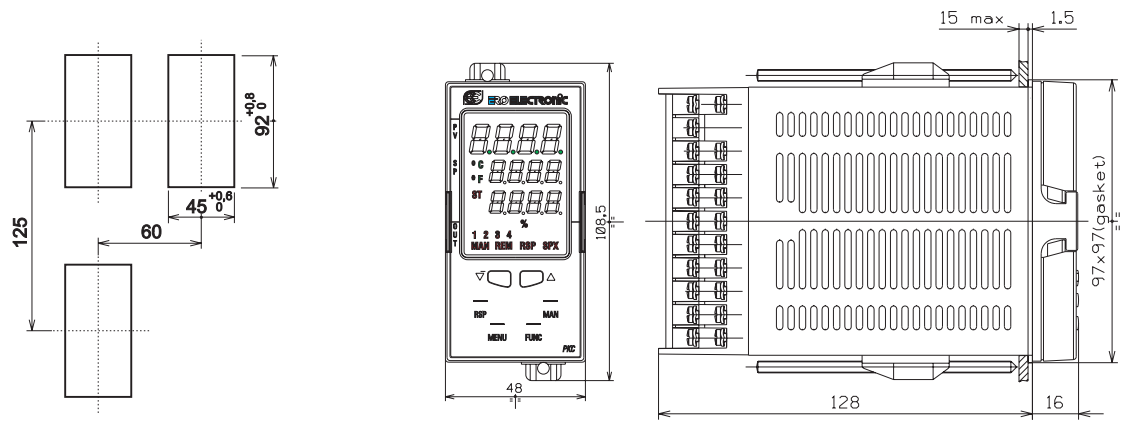

Fig. 2.A OUTLINE AND CUT-OUT DIMENSIONS FOR PKC MODEL

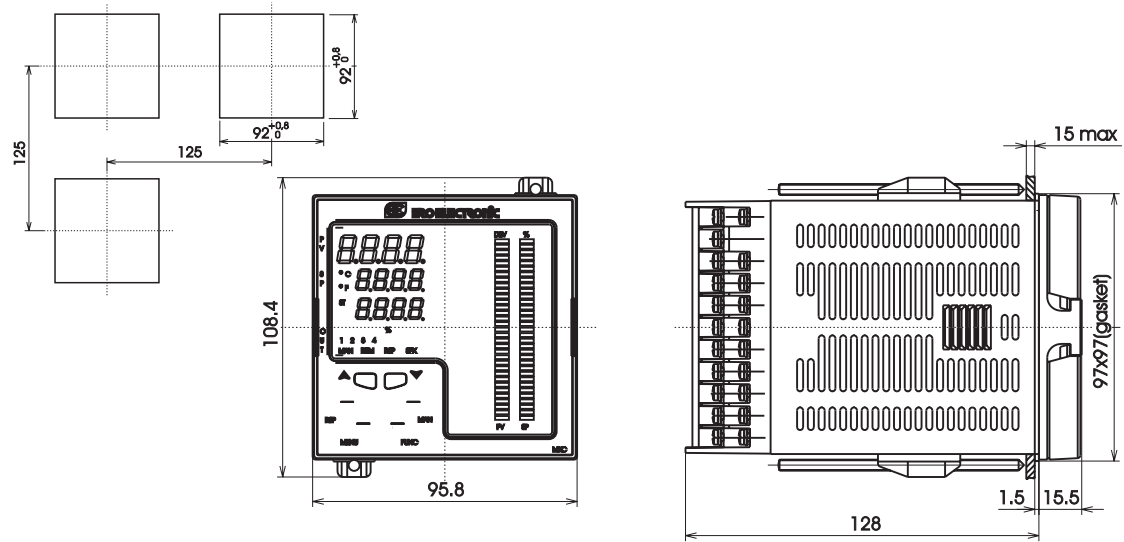

Fig. 2.B OUTLINE AND CUT-OUT DIMENSIONS FOR MKC MODEL

### CONNECTION DIAGRAMS

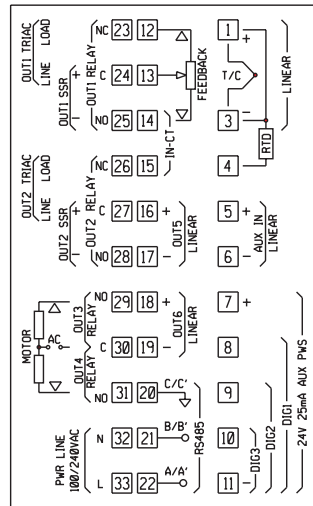

Fig. 3.A PKC -REAR TERMINAL BLOCK

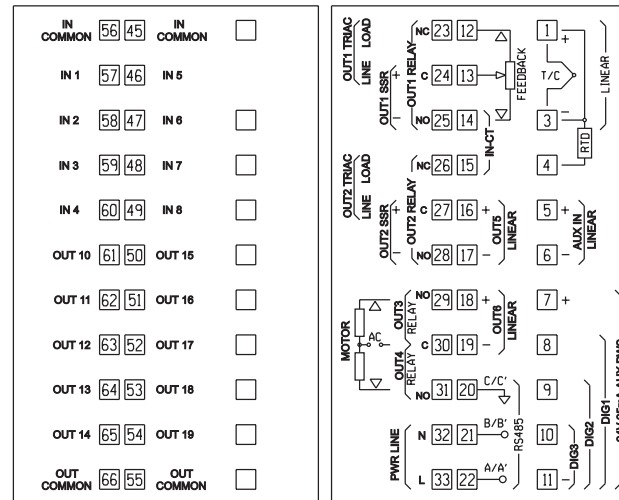

Fig. 3.B MKC REAR TERMINAL BLOCK





Connections are to be made with the instrument housing installed in its proper location.

**A) MEASURING INPUTS**

**NOTE:** Any external component (like zener barriers etc.) connected between sensor and input terminals may cause errors in measurement due to excessive and/or not balanced line resistance or possible leakage currents.



**A.1) TC INPUT**

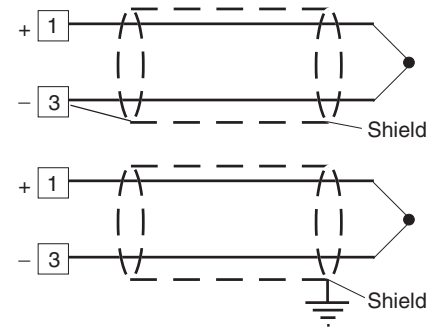

Fig. 4 THERMOCOUPLE INPUT WIRING

**NOTES:**

- 1) Don't run input wires together with power cables.
- 2) For TC wiring use proper compensating cable preferable shielded.
- 3) When a shielded cable is used, it should be connected at one point only.



### A.2) RTD INPUT

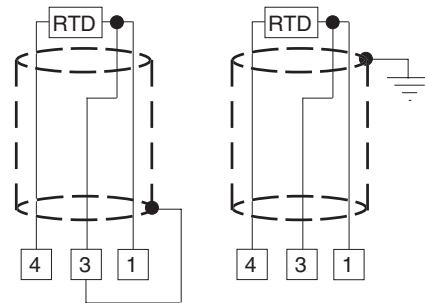

Fig. 5 RTD INPUT WIRING

**NOTES:**

- 1) Don't run input wires together with power cables.
- 2) Pay attention to the line resistance; a high line resistance may cause measurement errors.
- 3) When shielded cable is used, it should be grounded at one side only to avoid ground loop currents.
- 4) The resistance of the 3 wires must be the same.

### A.3) LINEAR INPUT

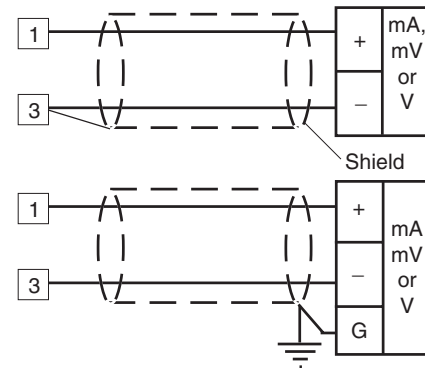

Fig. 6 mA, mV AND V INPUTS WIRING

**NOTES:**

- 1) Don't run input wires together with power cables.
- 2) Pay attention to the line resistance; a high line resistance may cause measurement errors.

- 3) When shielded cable is used, it should be grounded at one side only to avoid ground loop currents.
- 4) The input impedance is equal to:
  - < 5  $\Omega$  for 20 mA input
  - > 1 M $\Omega$  for 60 mV input
  - > 200 k $\Omega$  for 5 V input
  - > 400 k $\Omega$  for 10 V input

**A.4) 2, 3 AND 4-WIRE TRANSMITTER INPUT**

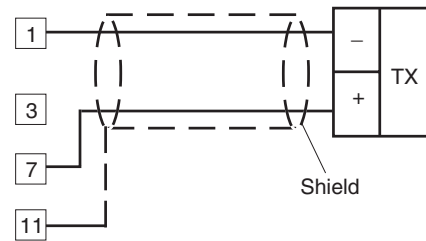

Fig. 7.A INPUTS WIRING FOR 2-WIRE TRANSMITTER

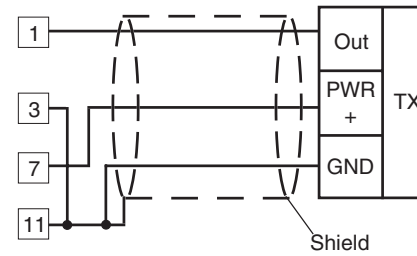

Fig. 7.B INPUTS WIRING FOR 3-WIRE TRANSMITTER

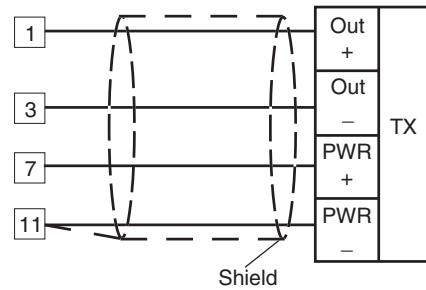

Fig. 7.C INPUTS WIRING FOR 4-WIRE TRANSMITTER

**NOTES:**

- 1) Don't run input wires together with power cables.
- 2) Pay attention to the line resistance; a high line resistance may cause measurement errors.
- 3) When shielded cable is used, it should be grounded at one side only to avoid ground loop currents.
- 4) The input impedance is lower than 5  $\Omega$  (20 mA input)

**B) AUXILIARY INPUT**

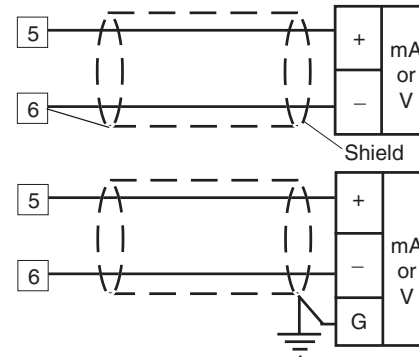

Fig. 8 AUXILIARY INPUT WIRING

**NOTES:**

- 1) This input is **not isolated** from measuring input. A double or reinforced insulation between instrument output and power supply must be assured by the external instrument.
- 2) Don't run input wires together with power cables.
- 3) Pay attention to the line resistance; a high line resistance may cause measurement errors.

- 4) When shielded cable is used, it should be grounded at one side only to avoid ground loop currents.
- 5) The input impedance is equal to:
  - < 5  $\Omega$  for 20 mA input
  - > 200 k $\Omega$  for 5 V input
  - > 400 k $\Omega$  for 10 V input

**C) LOGIC INPUT**

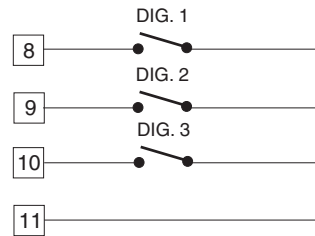

Fig. 9.A - LOGIC INPUTS DIG.1, 2 and 3 WIRING

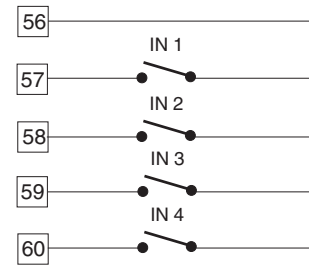

Fig. 9.B - LOGIC INPUTS IN 1, 2, 3 and 4 WIRING

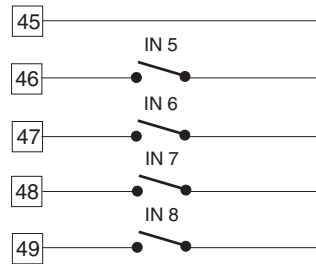

Fig. 9.c - LOGIC INPUTS IN 5, 6, 7 and 8 WIRING

**NOTES:**

- 1) Do not run logic input wiring together with power cables.
- 2) Use an external dry contact capable of switching 0.5 mA, 5 V DC.
- 3) The instrument needs 110 ms to recognize a contact status variation.
- 4) The logic inputs are **NOT** isolated by the measuring input. A double or reinforced insulation between instrument output and power supply must be assured by the external element.

**D) CURRENT TRANSFORMER INPUT**

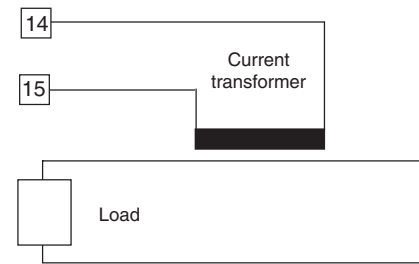

Fig. 10 CURRENT TRANSFORMER INPUT WIRING

This input allows you to measure and display the current running in the load, driven by a time proportional control output, during the ON and OFF periods of the output cycle time. By this feature it is also available the "Output failure detection" function (see page 66).

**NOTES:**

- 1) This input is **not isolated** from measuring input. A double or reinforced insulation between instrument output and power supply must be assured by the external element.
- 2) Do not run current transformer input wiring together with AC power cables.
- 3) The minimum active period to perform this measurement is equal to 120 ms.
- 4) The input impedance is equal to 20  $\Omega$ .

**E.1) RELAY OUTPUTS**

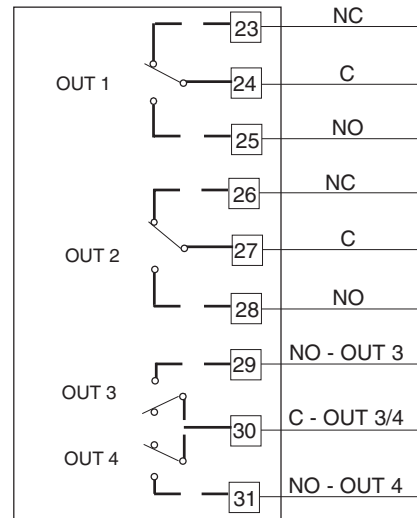

Fig. 11.A RELAY OUTPUTS 1,2,3 and 4 WIRING

The outputs from OUT 1 to OUT 4 are equipped with relays having contact rating equal to 3A/250V AC on resistive load.

**WARNING:** When OUT 3 and 4 are used as independent relay outputs the addition of the two currents must not exceed 3 A.

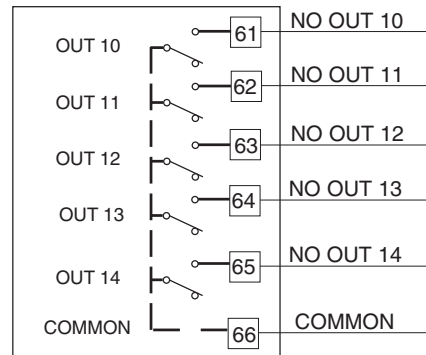

Fig. 11.B RELAY OUTPUTS 10 to 14 WIRING

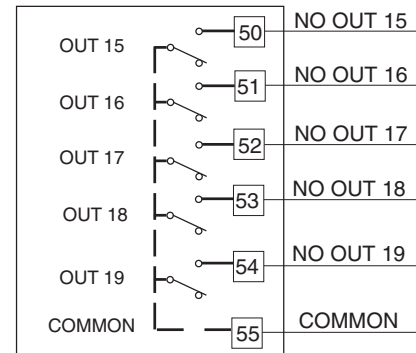

Fig. 11.C RELAY OUTPUTS 15 to 19 WIRING

The outputs from OUT 10 to 19 are equipped with relays having contact rating equal to 0.5A/250V AC on resistive load.



- NOTES**
- 1) To avoid electrical shock, connect power line at the end of the wiring procedure.
  - 2) For power connections use No 16 AWG or larger wires rated for at least 75 °C.
  - 3) Use copper conductors only.
  - 4) Don't run input wires together with power cables.
- All relay contacts are protected by varistor against inductive load with inductive component up to 0.5 A.

The following recommendations avoid serious problems which may occur, when using relay output for driving inductive loads.

**INDUCTIVE LOADS**

High voltage transients may occur switching inductive loads. Through the internal contacts these transients may introduce disturbances which can affect the performance of the instrument.

For all the outputs, the internal protection (varistor) assures a correct protection up to 0.5 A of inductive component.

The same problem may occur when a switch is used in series with the internal contacts as shown in Fig. 12.

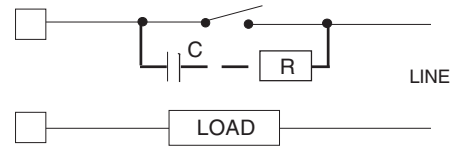

Fig. 12 EXTERNAL SWITCH IN SERIES WITH THE INTERNAL CONTACT

In this case it is recommended to install an additional RC network across the external contact as show in Fig. 12. The value of capacitor (C) and resistor (R) are shown in the following table.

LOAD (mA)	C (µF)	R (Ω)	P. (W)	OPERATING VOLTAGE
<40 mA	0.047	100	1/2	260 V AC
<150 mA	0.1	22	2	260 V AC
<0.5 A	0.33	47	2	260 V AC

Anyway the cable involved in relay output wiring must be as far away as possible from input or communication cables.

### E.2) VOLTAGE OUTPUTS FOR SSR DRIVE

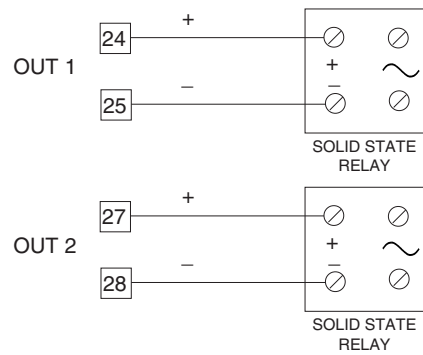

Fig. 13 SSR DRIVE OUTPUT WIRING

**Logic level 0:**  $V_{out} < 0.5 \text{ V DC}$ .

**Logic level 1:**

-  $14 \text{ V} \pm 20\% @ 20 \text{ mA}$

-  $24 \text{ V} \pm 20\% @ 1 \text{ mA}$ .

Maximum current = 20 mA.

**NOTE:** This output is not isolated.

A double or reinforced insulation between instrument output and power supply must be assured by the external solid state relay.

### E.3) TRIAC OUTPUTS

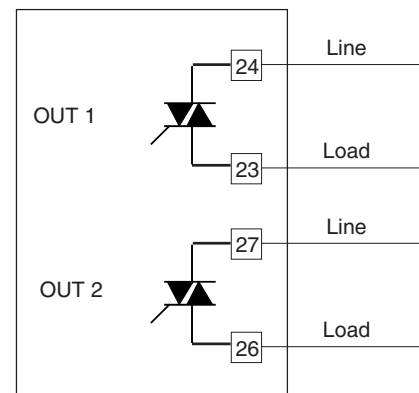

Fig. 14 TRIAC OUTPUT WIRING

**Switching mode:** isolated zero crossing type.  
**Rated current:** from 50 mA to 1 A.  
**Rated voltage:** from 24 V<sub>RMS</sub> to 240 V<sub>RMS</sub> -10 % +15 % (50/60Hz)

**Load type:** resistive load only

- NOTES**
- 1) To avoid electrical shock, connect power line at the end of the wiring procedure.
  - 2) For power connections use No 16 AWG or larger wires rated for at last 75 °C.
  - 3) Use copper conductors only.
  - 4) Don't run input wires together with power cables.
  - 5) This output is not fuse protected. Please, provide it externally using a fuse with a I<sup>2</sup>t equal to 128.

#### E.4) SERVOMOTOR OUTPUT

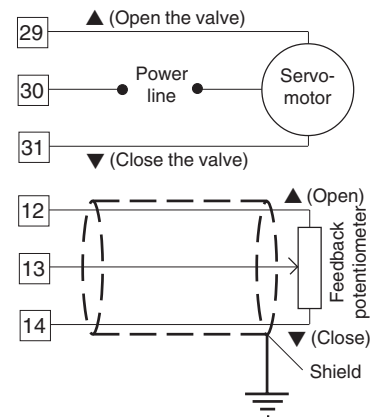

Fig. 15 SERVOMOTOR OUTPUT WIRING

The two relay output must be interlocked (see chapter "Preliminary hardware setting" paragraph "Out 3 and 4 selection").

**NOTES:**

- 1) Before connecting the instrument to the power line, make sure that line voltage and the load current are in accordance with the contact rating (3A/250V AC on resistive load).
- 2) To avoid electric shock, connect power line at the end of the wiring procedure.
- 3) For servomotor connections use No 16 AWG or larger wires rated for at least 75 °C.
- 4) Use copper conductors only.
- 5) Don't run input wires together with power cables.
- 6) For feedback potentiometer, use shielded cable with the shield connected to the earth at one point only.
- 7) The relay outputs are protected by varistor against inductive load with inductive component up to 0.5 A.

**E.5) ANALOG OUTPUTS**

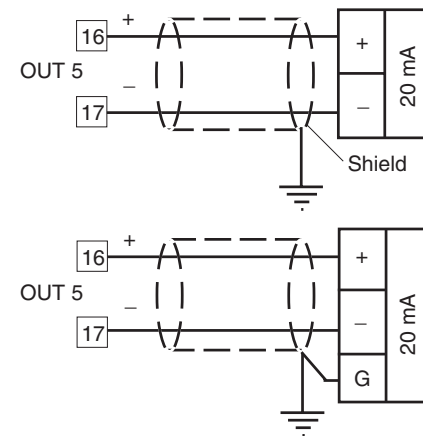

Fig. 16.A OUTPUT 5 WIRING

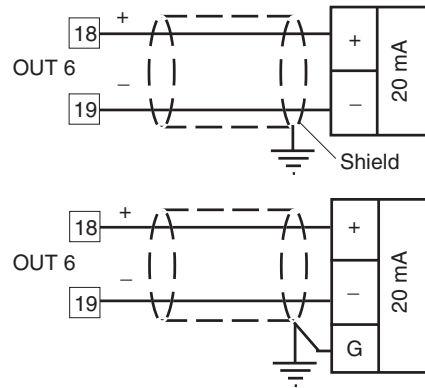

Fig. 16.B OUTPUT 6 WIRING

**NOTE:**

- 1) Do not run analog output wirings together with AC power cables.
- 2) Out 5 and 6 are isolated outputs.
- 3) The maximum load is equal to 600 Ω.

**F) SERIAL INTERFACE**

RS-485 interface allows you to connect up to 30 devices with one remote master unit.

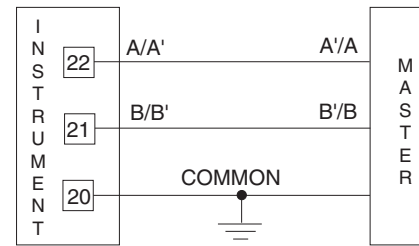

Fig. 17 - RS-485 WIRING

**NOTES:**

- 1) The cable length must not exceed 1.5 km at 9600 BAUD.
- 2) This serial interface is isolated.
- 3) The following report describes the signal sense of the voltage appearing across the interconnection cable as defined by EIA for RS-485.
  - a) The "A" terminal of the generator shall be negative with respect to the "B" terminal for a binary 1 (MARK or OFF) state.

- b) The "A" terminal of the generator shall be positive with respect to the "B" terminal for a binary 0 (SPACE or ON).
- 4) The EIA standard establishes that by RS-485 interface it is possible to connect up to 30 devices with one remote master unit.
- The serial interface of these instruments is based on "High input impedance" transceivers; this solution allows you to connect up to 127 devices (based on the same transceiver type) with one remote master unit.

#### G) POWER LINE WIRING

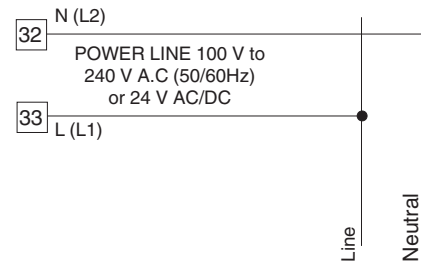

Fig. 18 POWER LINE WIRING

#### NOTES:

- 1) Before connecting the instrument to the power line, make sure that line voltage corresponds to the description on the identification label.
- 2) To avoid electrical shock, connect power line at the end of the wiring procedure.
- 3) For supply connections use No 16 AWG or larger wires rated for at least 75 °C.

- 4) Use copper conductors only.
- 5) Don't run input wires together with power cables.
- 6) For 24 V DC the polarity is a not care condition.
- 7) The power supply input is fuse protected by a sub miniature fuse rated T, 1A, 250 V.

When fuse is damaged, it is advisable to verify the power supply circuit, so that it is necessary to send back the instrument to your supplier.

- 8) The safety requirements for Permanently Connected Equipment say:
  - a switch or circuit-breaker shall be included in the building installation;
  - it shall be in close proximity to the equipment and within easy reach of the operator;
  - it shall be marked as the disconnecting device for the equipment.

**NOTE:** a single switch or circuit-breaker can drive more than one instrument.

- 9) When a neutral line is present please connect it to the 32 terminal.

## PRELIMINARY HARDWARE SETTINGS

### How to remove the instrument from its case

- 1) Switch off the instrument.
- 2) Push gently the lock A on the right.
- 3) While the lock A is maintained out, slide out the right side of the instrument (see fig. 19.a)



Fig. 19.a

- 4) Push gently the lock C on the left.
- 5) While the lock C is maintained out, slide out the instrument (see fig. 19.b)

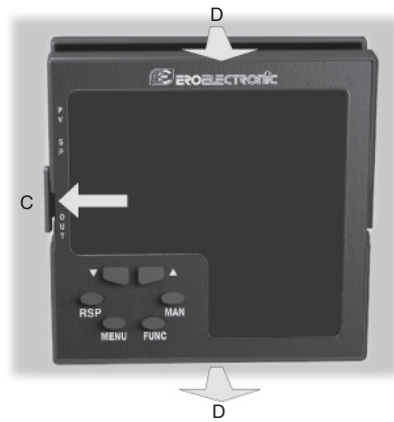

Fig. 19.b

#### MAIN INPUT SELECTION

Set J103 (see fig. 20) according to the desired input type as shown in the following table.

J103	INPUT TYPE				
	T/C, RTD	60 mV	5 V	10 V	20 mA
1-2	open	open	close	open	open
3-4	open	open	close	close	open
5-6	open	open	open	open	close
7-8	open	open	open	open	close
5-7	close	close	open	close	open
6-8	close	close	open	open	open



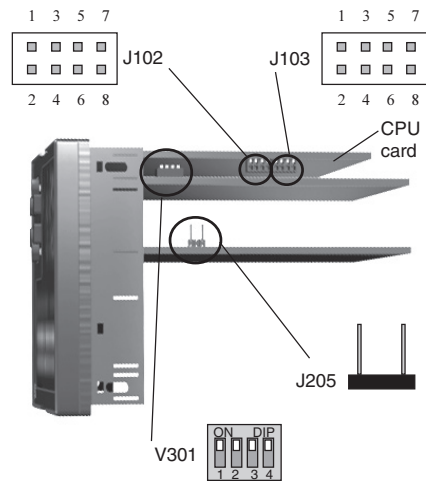

Fig. 20

**AUXILIARY INPUT SELECTION (option)**

Set J102 (see fig. 20) according to the desired input type as shown in the following table.

J102	INPUT TYPE		
	5 V	10 V	20 mA
1-2	close	open	open
3-4	close	close	open
5-6	open	open	close
7-8	open	open	close
5-7	open	close	open
6-8	open	open	open

### OUTPUT 3 AND 4 SELECTION

Output 3 and 4 can be set as:

- 2 independent relay outputs
- 1 servomotor output with interlocked contact.

Set J204 (see fig. 21) and J205 (see fig. 20) according to the desired output type as shown in the following table.

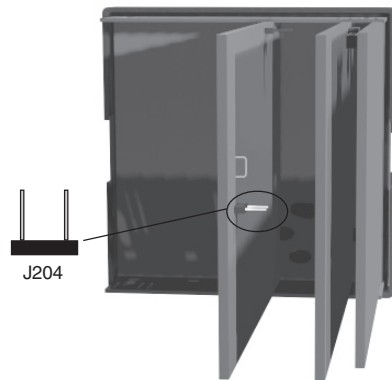

Fig.21

Output	J 204	J 205
Relay	close	open
Servo	open	close

**NOTE:** when the servomotor close loop or the servomotor open loop with valve position indication outputs is required, it will be necessary to set also V301 (see "IN CT/Feedback selection" paragraph)

### IN CT / FEEDBACK SELECTION

This instrument can use the "IN CT" input or the "Feedback" input; the two inputs are not contemporarily.

The current transformer input allows you to measure and display the current running in a load driven by a time proportional control output during the ON and OFF periods of the output cycle time. By this feature it is also available the "Out failure detection" function (see page 66).

The feedback input is used when the servomotor close loop or the servomotor open loop with valve position indication outputs is required.

To select the desired input type, set V301 (see fig. 20) as detailed in the following table:

Input	V301.1	V301.2	V301.3	V301.4
IN CT	ON	OFF	ON	ON
Feedback	OFF	ON	OFF	ON

**OPTION CHECK**

This instrument can be supplied with many options.  
 Two integrated circuits (KY101 and KY103), located as shown in fig. 22 and inserted in a socket, give you the possibility to verify if your instrument is equipped with the desired option.  
 When KY101 is present the auxiliary input and the digital inputs are present.  
 When KY103 is present the auxiliary power supply option is present.

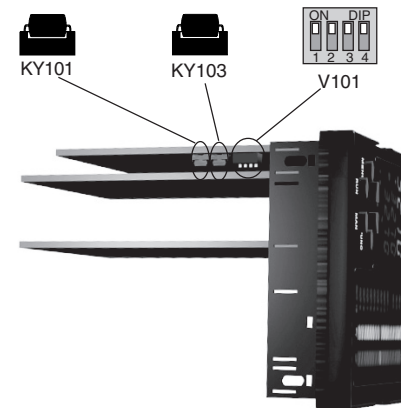

Fig. 22

### Operative mode and Hardware lock

1) By V101 (see fig 22) it is possible to select one of the following operative modes:

- a) run time mode without configuration mode
- b) run time and configuration modes
- c) security code setting mode

Set V101 according to the following table:

Modes	V101.1	V101.2	V101.3	V101.4
a	OFF	ON	ON	ON
b	OFF	ON	OFF	ON
c	OFF	ON	OFF	OFF

2) When run time mode is selected (mode a or b), V101.3 allows you to activate/deactivate the hardware lock for configuration parameters.

If V101.3 is ON, the lock is activated.

If V101.3 is OFF, the lock is deactivated.

When the lock is activated, no one of the configuration parameter can be modified.

3) All the others switch combinations are reserved.

### SECURITY CODE SETTING MODE

#### General notes

The instrument parameters are divided in two families and each family is divided in groups.

- The first family encompasses all the run time parameters.
- The second family comprises all the configuration parameters.

A specific security code enables the parameter modification of each family.

For run time parameters, it is possible to select which groups of them will be protected by the security code and in this case it is necessary to set the run time security code before to modify one or more parameters of a protected group.

The configuration security code protects all configuration parameters and it will be necessary to set the configuration security code before to start the configuration parameters modification.

For configuration parameters an hardware lock is also available.

#### Security code setting:

- 1) Remove the instrument from its case.
- 2) Set the internal dip switch V101 as follows:
  - V101.1 = OFF- V101.2 = ON
  - V101.3 = OFF- V101.4 = OFF
- 3) Re-insert the instrument.
- 4) Switch on the instrument. The display will show:

S c r t

A 0 1

The upper display shows that the security code setting mode is selected while the lower display shows the firmware version.

- 5) Push the FUNC pushbutton.

#### Run time security code

The display will show:

S c r t

S . r u n

**Note:** the middle display shows the current status of the run time security code ("0", "1" or "On").

By ▲ and ▼ push-button, set "S.run" parameter as follows:

- 0 No protection (it is ever possible to modify all run time parameters);
  - 1 ever protected (it is never possible to modify a run time parameter);
- from 2 to 250 security code for run time parameter protection.

#### NOTES:

- 1) the selected value of a security code cannot be displayed anymore and, coming back to the "S.run" parameter, the display will show "On" when "S.run" is different from 0 or 1, "0" when "S.run" is equal to 0, "1" when "S.run" is equal to 1. When the security code is forgotten, a new value can be set.
- 2) When "S.run" is different from 0 or 1, the "run time default " and the "run time hidden" groups are ever protected by security code.

### Run time groups protected by security code

The display will show:

```
S c r t
  Y E S
  G r 1
```

By this parameter it is possible to set if the run time group 1 will be protected or not by the run time security code.

By ▲ and ▼ push-button, set "Gr1" parameter as follows:

- n0 No protection (it is always possible to modify run time group 1 parameters)
- Yes the run time group 1 parameter modification will be protected by security code.

Push the FUNC push-button; the instrument memorizes the new setting and goes to the next parameter.

**NOTE:** the above described selection may be repeated for all groups of the run time mode.

### Configuration security code

The display will show:

```
S c r t
  - - -
  S c n F
```

**Note:** the middle display shows the actual status of the configuration security code ("0", "1" or "On").

By ▲ and ▼ push-button, set "S.CnF" parameter as follows:

- 0 No protection (it is ever possible to modify all configuration parameters);
  - 1 ever protected (it is never possible to modify a configuration parameter);
- from 2 to 250 security code for configuration parameter protection.

**NOTE:** the selected value of a security code cannot be displayed anymore and, coming back on the "S.CnF" parameter, the display will show "On" when "S.CnF" is different from 0 or 1, "0" when "S.CnF" is equal to 0, "1" when "S.CnF" is equal to 1.  
When the security code is forgotten, a new value can be set.

## RUN TIME AND CONFIGURATION MODES







The hardware selection described in "Operative mode and hardware lock" paragraph allows you to start one of the two following operative modes:

- run time mode
- configuration mode.

At power up, the instrument starts in the same mode it was prior to the power OFF.



### General note about graphic symbols used for mnemonic code visualization.



The instrument displays some characters with special symbols. The following table shows the correspondence between the symbols and the characters



symbol	character
"  "	k
"  "	m
"  "	V
"  "	W
"  "	Z
"  "	J

## Keyboard description

MENU =  is used to select a parameter group

FUNC =  when the instrument is in "normal display mode" it changes the indication on the lower display (see "display function").  
 During parameter modification, it allows you to memorize the new value of the selected parameter and go to the next parameter (increasing order).

MAN =  when the instrument is in "normal display mode", pushing MAN push-button for more than 1 s, it is possible to enable or disable the manual function.  
 During parameter modification, it allows you to scroll back the parameters and groups without memorizing the new setting.

 =  During parameter modification, it allows you to increase the value of the selected parameter  
 During MANUAL mode, it allows you to increase the output value.

- ▼ =  During parameter modification, it allows you to decrease the value of the selected parameter
- During MANUAL mode, it allows to decrease the output value.
- RSP = allows to toggle from Local set point to Remote set point or viceversa when depressed for more than 1 sec.
- ▼+MENU= are used to start the lamp test function (the command is accepted when push-button are kept depressed for more than 5 s and device is in normal display mode)
- ▲+FUNC or ▼+FUNC  
During parameter modification they allow you to increase/decrease the value under modification with higher rate.
- ▲+MAN or ▼+MAN  
During parameter modification they allow you to jump to the max or min programmable value.

**NOTES:**

- 1) All the actions explained above which requires two or more push-buttons must follow exactly the push-button sequence shown.
- 2) A 10 or 30 seconds time out (see "t.out" [C.110]) can be selected for parameter modification during run time mode. If, during parameter modification, no push-button is depressed for more than 10 (30) seconds, the instrument goes automatically to the "normal display mode" and the eventual modification of the last parameter will be lost.



### CONFIGURATION MODE

Switch on the instrument.

The instrument will start in the same way it was prior to the power down (configuration mode or run time mode)

If the instrument starts in configuration mode, push the MENU pushbutton and go to the "Configuration group 1" (see page 30). If the instrument starts in run time mode, by keeping depressed the MENU push-button for more than 5 seconds the instrument will show:

```
CnF
mon.
AQ1
```

#### NOTES:

- 1) The upper display shows the selected parameter family.
- 2) The middle display shows the selected action.
- 3) The lower display shows the firmware version.
- 4) If no push-button is depressed for more than 10 s (or 30 s according to "CnF.6" "t.out" [time out selection" C.I10] parameter setting), the instrument returns automatically to the normal display mode.

By ▲ or ▼ push-button it is possible to select between:

$\bar{n}on.t.$  = (monitor) this selection allows you to monitor but not to modify the value assigned to the configuration parameters

$\bar{n}od.F.$  = (modify) this selection allows you to monitor and to modify the value assigned to the configuration parameters.

#### NOTES:

- 1) During monitor mode, the instrument continues to operate as in run time mode.
- 2) When modify mode is started, the instrument stops the control and:
  - sets control outputs to OFF;
  - turns OFF the bargraph displays (MKC only);
  - sets analog retransmissions to the retransmitted initial scale value;
  - sets alarms in no alarm condition;
  - sets events to OFF;
  - disables the serial link;
  - the time out will be removed.
- 3) When the modify mode is disabled by V101 (V101.3), the ▲ or ▼ push-button pressure has no effect.

### MONITOR MODE

During the run time mode, it is possible to monitor but not modify all configuration parameters.

When it is desired to verify the instrument configuration, proceed as follows:

- 1) By ▲ or ▼ push-button select the monitor mode.
- 2) Push the MENU push-button the display will show:

*CnF. 1*

*INPt.*

it shows that configuration group 1 is selected and it encompass all the input parameters.

The configuration parameter "Monitor mode" follows the "Modify mode" sequence.

#### NOTES:

- 1) During monitor mode, the instrument continues to operate as in run time mode.
- 2) During monitor mode, if no push-button is depressed for more than 10 s (or 30 s according to "t.out" [C.110] parameter setting), the instrument returns automatically to the normal display mode.

### MODIFY MODE

- 1) By ▲ or ▼ push-button select the modify mode.

- 2) Push the MENU push-button.

If a security code is applied to the configuration parameter, the instrument will show:

*CnF*

*----*

*SCrE*

- 3) By ▲ and ▼ push-button set a value equal to the security code assigned to the configuration mode (see "Configuration security code " at page 24).

If the code is different from the security code, the instrument automatically returns to the first configuration display otherwise the display will show:

*CnF*

*OFF*

*dFLt.*

The modify mode is started.  
This display allows you to load the default configuration parameter.  
For more details see chapter "Default parameter" (see Appendix A).

- 4) By ▲ or ▼ push-button select the OFF indication and push the MENU push-button.

The display will show:

*CONF.*

*INPT.*

This is the starting display of the first group of configuration parameters.

**NOTES:**

- 1) In the following pages we will describe all the parameters of the instrument but the instrument will show only the parameters related with the specific hardware and in accordance with the specific instrument configuration (i.e. setting OUT 3 different from servo, all the parameters related with servomotor output will be skipped).

- 2) During configuration parameters modify mode, the upper display shows the selected parameter group, the lower display shows the mnemonic code of the selected parameter while the central display shows the value or status assigned to the selected parameter.
- 3) For an easy consultation of this manual, a table with all the parameter visualizations is enclosed.

When it is desired to exit from configuration modify mode proceed as follows:

- a) Push "MENU" push-button until the "Configuration group END" is displayed.
- b) Pushing "▲" or "▼" push-button select the "YES" indication.
- c) Push "MENU" push-button. The instrument terminates the configuration modify mode, it performs an automatic reset and restarts in the run time mode.

CnF. 1

**CONFIGURATION GROUP 1 [C.dxx]**  
MAIN AND AUXILIARY INPUT CONFIGURATION

CnF. 1

INPT.

Push the FUNC push-button

**LrFr** - Line frequency - [C.d01]

Range: 50 Hz  
60 Hz

**r.inL** - Main input type and range - [C.d02]

Ranges:

- \* 1 = TC L From -100 to 900 °C
- \* 2 = TC J From -100 to 1000 °C
- \* 3 = TC K From -100 to 1370 °C
- \* 4 = TC T From -200 to 400 °C
- \* 5 = TC U From -200 to 600 °C

- \* 6 = TC E From -100 to 800 °C
- 7 = TC N From -100 to 1400 °C
- 8 = TC S From - 50 to 1760 °C
- 9 = TC R From - 50 to 1760 °C
- 10 = TC B From 0 to 1820 °C
- 11 = TC G (or W) From 0 to 2300 °C
- 12 = TC D (or W3) From 0 to 2300 °C
- 13 = TC C (or W5) From 0 to 2300 °C
- 14 = TC Ni-Ni18%Mo From 0 to 1200 °C
- \* 15 = RTD Pt100 From -200 to 850 °C
- 16 = TC L From -150 to 1650 °F
- 17 = TC J From -150 to 1830 °F
- 18 = TC K From -150 to 2500 °F
- 19 = TC T From -330 to 750 °F
- 20 = TC U From -330 to 1110 °F
- 21 = TC E From -150 to 1470 °F
- 22 = TC N From -150 to 2550 °F
- 23 = TC S From - 60 to 3200 °F
- 24 = TC R From - 60 to 3200 °F
- 25 = TC B From 32 to 3300 °F
- 26 = TC G ( or W) From 0 to 4170 °F
- 27 = TC D (or W3) From 0 to 4170 °F
- 28 = TC C (or W5) From 0 to 4170 °F
- 29 = TC Ni-Ni18%Mo From 0 to 2190 °F
- \* 30 = RTD Pt100 From -330 to 1560 °F

31 = Linear	From	0 to	20 mA
32 = Linear	From	4 to	20 mA
33 = Linear	From	0 to	5 V
34 = Linear	From	1 to	5 V
35 = Linear	From	0 to	10 V
36 = Linear	From	2 to	10 V
37 = Linear	From	0 to	60 mV
38 = Linear	From	12 to	60 mV

\* For these ranges it is possible to select a read-out with one decimal figure but the instrument could not display a measure lower than -199.9 or higher than 999.9 and the input range will be limited by it.

**NOTES:**

- 1) When a linear input is selected, the instrument set automatically the "readout initial scale value" [C.d05] equal to 0 and the "readout final scale value" [C.d06] equal to 4000
- 2) When input type has been changed, the instrument automatically forces:
  - the "n.In.L" [C.d05], "SS.th" [C.I09] and "brG.L" [C.I03] parameters to the new initial scale value,
  - the "n.In.H" [C.d06] and "brG.H" [C.I04] parameter to the new final scale value and
  - the "n.In.d" [C.d03] parameter to "no decimal figure".

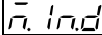
 - **Decimal point position - [C.d03]**

Ranges: ----. = no decimal figure  
 ----. = one decimal figure  
 ----. = two decimal figures  
 ----. = three decimal figures

**NOTES:**

- 1) For main input type 1 to 6, 15 and 30 only the "no decimal figure" and "one decimal figure" are selectable, the input range is limited within -199.9 and 999.9 and it acts as an input type change.
- 2) For main input type 7 to 14 and 16 to 29 this parameter is not available.
- 3) For linear input types (from 31 to 38) all positions are available.

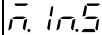
 - **Square root extraction for main input- [C.d04]**

Ranges: dIS = square root extraction disabled  
 Enb = square root extraction enabled

CnF.1

**NOTES:**

- 1) This parameter is available only for main input type 31 to 38.
- 2) When the square root extraction is enabled the "ñ.In.L" (read-out - initial scale value [C.d05]), "ñ.In.H" (read-out - full scale value [C.d06]), "brG.L" (bargraph - initial scale value [C.I03]), "brG.H" (bargraph - full scale value [C.I04]) and "SS.th" (threshold to enable the soft start [C.I09]) parameter values must be positive or equal to zero.  
Enabling the square root extraction the instrument verify the actual value of the "ñ.In.L", "ñ.In.H", "brG.L", "brG.H" and "SS.th" parameters and force to zero the eventual negative values.

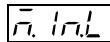
**Read-out - initial scale value - [C.d05]**

- Ranges: - from -1999 to 9999 for linear input (Input range 31 to 38),  
 - from 0 to 9999 for linear input with square root extraction,  
 - from initial range value to "ñ.In.H" (read-out- full scale value C.d06) for TC/RTD input

**NOTE:** Changing the value of this parameter, the "brG.L" (bargraph - initial scale value [C.I03]) and "rL" (set point low limit [r.E12]) parameters will be realigned to it.

If a linear input is selected, also the "SS.th" (threshold for soft start [C.I09]) will be realigned to it.

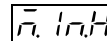
**Read-out - full scale value - [C.d06]**

- Ranges: - from -1999 to 9999 for linear input (Input range 31 to 38),  
 - from 0 to 9999 for linear input with square root extraction,  
 - from "ñ.In.L" (read-out- initial scale value [C.d05]) to full range value for TC/RTD input.

**NOTES:**

- 1) Changing the value of this parameter, the "brG.H" (bargraph - full scale value [C.I04]) and "rH" (set point high limit [r.E13]) parameters will be realigned to it.
- 2) The programmed input span, in absolute value, must be greater than:  
 300 °C or 550 °F for TC inputs  
 100°C or 200 °F for RTD inputs  
 100 digits for linear inputs.

**OFSt** - Offset on the main input - [C.d07]

Ranges: from -500 to 500.

**NOTE:** the decimal point will be automatically positioned as selected for the main input.

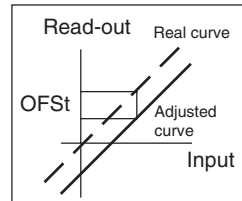

**DSFL** - Filter on the displayed value - [C.d08]

Ranges: from 0 (no filter) to 8 seconds.

**NOTE:** this is a first order digital filter applied to the read-out of the main input.

**A.In.F** - Auxiliary input function - [C.d09]

Range: nonE = Input not used

rSP = Input used as remote set point input

bIAS = Input used as bias for local set point

**NOTES:**

- 1) When auxiliary input option is not mounted the middle display will show "no.Pr" (not present).
- 2) The parameter "L.r.O.n" [C.d16] will be forced to "n.ALG" if "A.In.F" [C.d09]= "bIAS" and "A.l.Añ" [C.d14]= "Cnd.A".
- 3) When "bIAS" is selected, the instrument uses as operative set point the sum of the local set point with the value measured by the auxiliary input scaled by "A.In.L" [C.D11] and "A.In.H" [C.d12] parameters.

CnF.1

CnF. 1

**A.InL** - Auxiliary input type - [C.d10]

This parameter will be skipped when the auxiliary input option is not mounted or "A.In.F" (auxiliary input function [C.d09]) is equal to "nonE".

Range: 0-20 = 0-20 mA  
4-20 = 4-20 mA  
0-5 = 0-5 V  
1-5 = 1-5 V  
0-10 = 0-10 V  
2-10 = 2-10 V

**A.InL** - Initial scale read-out of the auxiliary input - [C.d11]

This parameter is available only when auxiliary input is configured

Range: from -1999 to 9999

**NOTE:** the decimal point will be automatically positioned as selected for the main input.

**A.InH** - Full scale read-out of the auxiliary input - [C.d12]

This parameter is available only when auxiliary input is configured

Range: from -1999 to 9999

**NOTE:** the decimal point will be automatically positioned as selected for the main input.

**A.FL** - Filter on auxiliary input - [C.d13]

This parameter is available only when auxiliary input is configured

Ranges: from 0 (no filter) to 8 seconds.

**NOTE:** this is a first order digital filter applied to the measured value made by the auxiliary input.

**A.InA** - Auxiliary input activation mode - [C.d14]

This parameter is available only when auxiliary input is configured

Range: norñ = The auxiliary input activation is controlled by external contact, front key or serial link



Cnd.A= The auxiliary input activation is controlled by its status (The device works with local set point when auxiliary input is out of range, while it works with remote set point (or bias) when it is within range)

**NOTE:** The parameter "L.r.O.n̄" (local/remote set point operative mode [C.d16]) will be forced to "n.ALG" if "A.In.F" (auxiliary input function [C.d09]) is equal to "BIAS" and "A.I.Añ" (auxiliary input activation mode [C.d14]) is equal to "Cnd.A".

#### **A.I.Sc** - Auxiliary input safety condition - [C.d15]

This parameter is available only when auxiliary input is configured and "A.i.Añ" [C.d14] is equal to "norñ".

Range: nonE = when the auxiliary input is out of range, the instrument operates as in presence of the min or max auxiliary input value.

Cnd.A = when the auxiliary input is out of range, the control output goes to safety value "SF.UL" (output safety value [C.G08]).  
If servomotor open loop control drive is configured the "Safety value" "SF.UL" [C.G08] has no effect and the instrument operates in

accordance with "SF.Cn" (Output safety condition [C.G07]) parameter setting.

**NOTE:** The "SF.Cn" (Output safety condition" [C.G07]) has the priority on "A.I.Sc" (auxiliary input safety condition [C.d15]).

#### **L.r.O.n̄** - Local/remote set point operative mode - [C.d16]

This parameter is available only when auxiliary input is configured

Range: ALG = when the transfer from remote to local set point is performed, the local set point value will be aligned to last remote set point value.

n.ALG = when the transfer from remote to local set point is performed, the local set point value will not be changed (The programmed ramps Grd1 [r.E14] and Grd2 [r.E15] may be activated).

#### **NOTES:**

- 1) The selected local set point will be changed even if it is software protected.
- 2) The parameter is forced to "n.ALG" if "A.In.F" (auxiliary input function [C.d09]) is equal to "BIAS" and "A.I.Añ" (auxiliary input activation mode [C.d14]) is equal to "Cnd.A"

Cnf. 1

CnF.2

### General note on configuration group 1

Exiting from the configuration group 1 the instrument verifies automatically the programmed span for the linear input. If it is wrong, the device will show:

CnF.1  
Err  
InPt

### CONFIGURATION GROUP 2 [C.Exx] OUTPUTS CONFIGURATION

CnF.2

OUT.

**OUT 1 function - [C.E01]**

Range: nonE = Output not used

nAin = Time proportional main control output

SECn = Time proportional secondary control output

ALr.1 = Alarm 1 output

Eun.1 = Event 1 output

**02.Fn** - OUT 2 function - [C.E02]

Range: nonE = Output not used  
 ñAin = Time proportional main control output  
 SECn = Time proportional secondary control output  
 ALr.2 = Alarm 2 output  
 Eun.2 = Event 2 output

**03.Fn** - OUT 3 function - [C.E03]

When the option is not mounted the middle display will show "no.Pr" (not present).  
 Range: nonE = Output not used  
 ñAin = Time proportional main control output  
 SECn = Time proportional secondary control output  
 ALr.3 = Alarm 3 output  
 Eun.3 = Event 3 output  
 ñC.Sñ = Servomotor control drive as main control output  
 SC.Sñ = Servomotor control drive as secondary control output

**04.Fn** - OUT 4 function - [C.E04]

Range: nonE = Output not used  
 ñAin = Time proportional main control output  
 SECn = Time proportional secondary control output  
 ALr.4 = Alarm 4 output  
 Eun.4 = Event 4 output

**NOTES:**

- 1) When option is not mounted the middle display will show "no.Pr" (not present).
- 2) When servomotor control drive is hardware selected (see "Output 3 and 4 selection" at pag. 20), the OUT 4 can be used only as servomotor drive.

**5n.LP** - Servomotor type - [C.E05]

This parameter will be available only when servomotor control drive is configured ("CnF.2 - O3.Fn" [C.E03]= "ñC.Sñ" or "SC.Sñ").  
 Range: CLSd = Close loop type  
**NOTE:** this selection is available only if feedback circuitry is mounted and selected.  
 OPEn = Open loop type

**FEED** - Valve position indication - [C.E06]

This parameter will be displayed only when open loop servomotor control drive output is configured.

Range: Fb = The valve position is measured and displayed  
no.Fb = The valve position is not measured

**NOTE:** If the feedback option is not mounted, this parameter will be forced to "no.Fb" (no feedback).

**O5Fn** - OUT 5 function - [C.E07]

Range: nonE = Output not used  
ñAin = Main control output (linear)  
SECn = Secondary control output (linear)  
PV.rt = Process variable retransmission  
SP.rt = Operative set point retransmission

**NOTE:** When the option circuitry is not mounted the middle display will show "no.Pr" (not present).

**O5r** - OUT 5 range - [C.E08]

This parameter will be available only when Out 5 is configured ("O5.Fn" [C.E07] different from "nonE")

Range: 0-20 = 0÷20 mA  
4-20 = 4÷20 mA

**O5Lr** - OUT 5 retransmission initial scale value - [C.E09]

This parameter will be available only when Out 5 function [C.E07] is configured as "PV.rt" or "SP.rt"

Range: From -1999 to 9999

**NOTE:** Decimal point is positioned as previously selected at "CnF.1 - ñ.In.d" [C.d03]

**O5Hr** - OUT 5 retransmission full scale value - [C.E10]

This parameter will be available only when Out 5 function [C.E07] is configured as "PV.rt" or "SP.rt"

Range: From -1999 to 9999

**NOTE:** Decimal point is positioned as previously selected at "CnF.1 - ñ.In.d" [C.d03]

**05.FL** - OUT 5 filter on the retransmitted value  
- [C.E11]

This parameter will be available only when OUT 5 is configured as process variable retransmission ("O5.Fn" [C.E07] is equal to "PV.rt").

Range: From 0 (no filter) to 8 seconds

**NOTE:** this is a first order digital filter applied to the retransmitted output value.

**06.Fn** - OUT 6 function - [C.E12]

Range: nonE = Output not used

nAin = Main control output (linear)

SECn = Secondary control output (linear)

PV.rt = Process variable retransmission

SP.rt = Operative set point retransmission

**NOTE:** When the option circuitry is not mounted the middle display will show "no.Pr" (not present).

**06.rn** - OUT 6 range - [C.E13]

This parameter will be available only when Out 6 is configured ("O6.Fn" [C.E12] different from "nonE")

Range: 0-20 = 0÷20 mA

4-20 = 4÷20 mA

**06.Lr** - OUT 6 retransmission initial scale value  
- [C.E14]

This parameter will be available only when Out 6 function [C.E12] is configured as "PV.rt" or "SP.rt"

Range: From -1999 to 9999

**NOTE:** Decimal point is positioned as previously selected at "CnF.1 - n.In.d" [C.d03].

CnF. 2

**06.Hr** - OUT 6 retransmission full scale value  
- [C.E15]

This parameter will be available only when Out 6 function [C.E12] is configured as "PV.rt" or "SP.rt"  
Range: From -1999 to 9999

**NOTE:** Decimal point is positioned as previously selected at "CnF.1 - n.In.d" [C.d03])

**06.Fl** - OUT 6 filter on the retransmitted value  
- [C.E16]

This parameter will be available only when OUT 6 is configured as process variable retransmission ("O6.Fn" [C.E12] is equal to "PV.rt").

Range: From 0 (no filter) to 8 seconds

**NOTE:** this is a first order digital filter applied to the retransmitted output value.

#### General notes on configuration group 2

I) Exiting from the configuration group 2 the instrument verifies automatically the congruence of all parameters. If a wrong setting is detected, the device will show:

CnF.2  
Err  
OUT.

The group 2 parameter passes the congruence test when:

- 1) Only one of the 6 outputs is configured as main output ("nAin")
- 2) Only one of the 6 outputs is configured as secondary output ("SEcn")
- 3) If only one control output is configured, it should be the main control output ("nAin")
- 4) The servomotor must be "close loop" type if it is one of two control outputs.

**NOTE:** The instrument may be used as an indicator, so that this test is satisfied even if no output is configured as control output

II) Exiting from the configuration group 2 also the following actions are automatically performed:

- A) The "Añ.UL" parameter ("Output value for auto to manual transfer" [C.G04]) will be forced to "bumpless" ("buñ") if:

- 1) its value is < 0 and only one control output is configured;
- 2) servomotor open loop without feedback is configured.
- B) The parameter "SF.Cn" ("Condition for output safety value" [C.G07]) will be forced to "standard" ("Std.") if it is not complied with configured control output type
- C) The parameter "SF.UL" ("Output safety value" [C.G08]) will be forced to 0 if only one control output is configured and its value is < 0.
- D) The parameter "Fd.Fn" ("Out failure detection current measurement" [C.I11]) will be forced to "nonE" if it is assigned to a control output different from a time proportional output.
- E) The parameter "Fd.Ou" ("Out failure detection output assignment" [C.I13]) will be forced to "nonE" if it is assigned to an output configured as control output
- F) The parameter "IP" ("Integral pre-load" [r.d05]) will be forced to 50.0 if only one control output is configured and its value is < 0

**CONFIGURATION GROUP 3 [C.Fxx]**  
CONTROL OUTPUT CONFIGURATION

**CnF.3**

**C.Cn**

**SPLLE** - Split range - [C.F01]

This parameter will be available only when two control outputs are configured.

- Range: dIS = Split range feature is not required
- Enb = Split range feature is required

**NOTE about the split range.**

This function allows you to drive by the same control action, two physical outputs (two actuators) with different bias and gain. The relation between the Calculated Power Output and the resulting real outputs are shown below:

CnF. 3

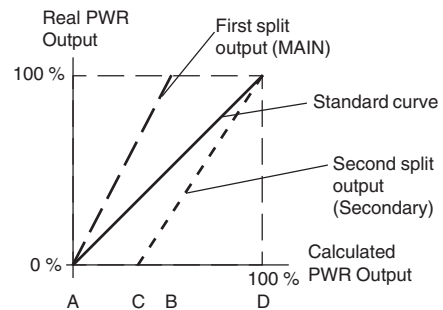

where:

- for the first split output (MAIN)
  - Bias 1 = -A
  - Gain 1 =  $100 / (B - A)$
- For the second split output (SECONDARY)
  - Bias 2 = -C
  - Gain 2 =  $100 / (D - C)$

**FOR EXAMPLE:**

Let's suppose that the first split output operates from 0 % to 33.3 % of the calculated output while the second one operates from 33.3 % to the 100 % of the calculated output.

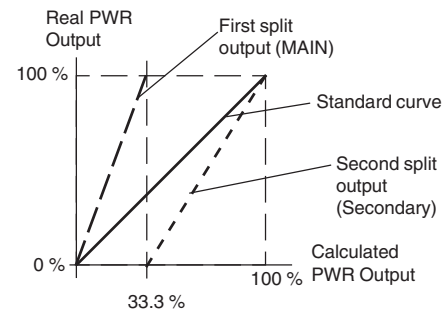

Where: A = 0 %  
 B = C = 33.3 %  
 D = 100 %

We will set:

- Bias 1 = 0
- Gain 1 =  $100 / (33.3 - 0) = 3$
- Bias 2 = - 33.3
- Gain 2 =  $100 / (100 - 33.3) = 1,5$



The bias and gain of the two split outputs are the following:  
 "nC.bs" [C.F03] is the Bias 1 applied to the main output  
 "nC.Gn" [C.F02] is the Gain 1 applied to the main output  
 "SC.bs" [C.F05] is the Bias 2 applied to the secondary output  
 "SC.Gn" [C.F04] is the Gain 2 applied to the secondary output

**nC.Gn** - Main control output gain - [C.F02]

This parameter will be available only when the split range is enabled ("SPLt." [C.F01] = "Enb").  
 Range: from 0.50 to 5.00.

**nC.bs** - Main control output bias - [C.F03]

This parameter will be available only when the split range is enabled ("SPLt." [C.F01] = "Enb").  
 Range: from -100.0 to 100.0 % of the output span.

**SC.Gn** - Secondary control output gain - [C.F04]

This parameter will be available only when the split range is enabled ("SPLt." [C.F01] = "Enb").  
 Range: from 0.50 to 5.00

**SC.bs** - Secondary control output bias - [C.F05]

This parameter will be available only when the split range is enabled ("SPLt." [C.F01] = "Enb").  
 Range: from -100.0 to 100.0 % of the output span.

**nC.Cn** - Main control output conditioning - [C.F06]

This parameter will be available only when main control output is configured.

- Range: norñ = The control output is calculated by the PID  
 CñPL = The control output is complemented (100-PID calculated value)  
 Quic = The control output is conditioned to match a "QUICK OPENING" flow characteristic  
 Eou = The control output is conditioned to match an "EQUAL PERCENTAGE" flow characteristic

**NOTE about output conditioning**

Sometimes non linear valves are used where a linear valve is suitable.  
 In these cases, it is advisable to linearize the ratio between flow rate and valve travel in order to obtain a better control of the process.

CnF. 3

This instrument allows you to select an output linearization in accordance with the two most common valve flow characteristics:

- Quick opening
- Equal percentage.

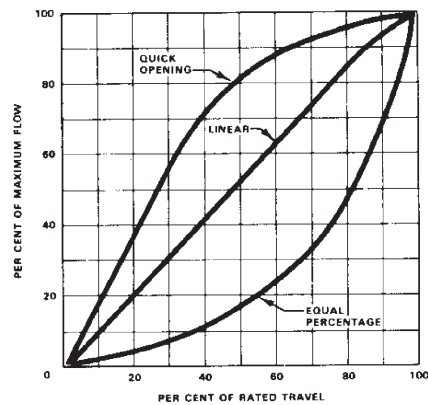

**n.SCL** - Main control output in engineering unit - [C.F07]

This parameter will be available only when main control output is configured.

Range: nO = Scalable is not required

YES = Scalable is required

**NOTE:** This scaling allows you to display the output value in engineering units instead of in percent.

**n.C.dp** - Main output decimal point position - [C.F08]

This parameter will be available only when "n.SCL" ("Main control output in engineering units" [C.F07]) is set to "yES".

Range: ----. = No decimal figure

----. = One decimal figure.

----. = Two decimal figures.

**ACEL** - Main output initial scale readout - [C.F09]

This parameter will be available only when "n.SCL" ("Main control output in engineering units" [C.F07]) is set to "YES".  
Range: from -199 to 999

**ACEH** - Main output full scale readout - [C.F10]

This parameter will be available only when "n.SCL" ("Main control output in engineering units" [C.F07]) is set to "YES".  
Range: from -199 to 999

**ACEC** - Main output auxiliary conditioning - [C.F11]

This parameter will be available only when main control output is configured and "n.Cn" ("Main control output conditioning" [C.F06]) is different from "norñ".

Range: bEFr = The functions listed at Note (\*\*) are calculated **before** to apply the action selected by "n.Cn" ("Main control output conditioning" [C.F06]) parameter.

AFtr = The functions listed at Note (\*\*) are calculated **after** to apply the action selected by "n.Cn" ("Main control output conditioning" [C.F06]) parameter.

**Note (\*\*)**

- "Main control output limiters" - for more details see [r.E04] and [r.E05] parameters.
- "Main control output max rate of rise" (see [r.E06]).
- "Control output display value" - for more details see "Display function" paragraph at pag. 62 and [C.F07], [C.F08], [C.F09] and [C.F10] parameters.
- "Threshold for alarm on control output value" - for more details see [r.F01], [r.F05] [r.F09] and [r.F13] parameters.
- The control output value displayed by bargraph.

CnF. 3

**SCLC** - Secondary control output conditioning  
- [C.F12]

This parameter will be available only when secondary control output is configured.

- Range: nor $\bar{n}$  = The control output is calculated by the PID  
 C $\bar{n}$ PL = The control output is complemented (100-PID calculated value)  
 Ouic = The control output is conditioned to match a "QUICK OPENING" flow characteristic  
 Eou = The control output is conditioned to match an "EQUAL PERCENTAGE" flow characteristic

For more details see also **NOTE about output conditioning** at page 43.

**S.SCL** - Secondary control output in engineering unit  
- [C.F13]

This parameter will be available only when secondary control output is configured.

- Range: nO = Scalable is not required  
 YES = Scalable is required

**NOTE:** This scaling allows to display the output value in engineering units instead of in percent.

**SCLDP** - Secondary control output decimal point  
position - [C.F14]

This parameter will be available only when "S.SCL" ("Secondary control output in engineering units" [C.F13]) is set to "YES".

- Range: ----. = No decimal figure  
 ----. = One decimal figure.  
 --. = Two decimal figures.

**SCEL** - Secondary control output initial scale value  
- [C.F15]

This parameter will be available only when "S.SCL" ("Secondary control output in engineering units" [C.F13]) is set to "YES".  
Range: from -199 to 999

**SCEH** - Secondary control output full scale value  
- [C.F16]

This parameter will be available only when "S.SCL" ("Secondary control output in engineering units" [C.F13]) is set to "YES".  
Range: From -199 to 999

**SCAL** - Secondary output auxiliary conditioning  
- [C.F17]

This parameter will be available only when secondary control output is configured and "SC.Cn" ("Secondary control output conditioning" [C.F12]) is different from "norñ".

Range: bEFr = The functions listed at Note (\*\*) are calculated **before** to apply the action selected by "SC.Cn" ("Secondary control output conditioning" [C.F12]) parameter.

AFtr = The functions listed at Note (\*\*) are calculated **after** to apply the action selected by "SC.Cn" ("Secondary control output conditioning" [C.F12]) parameter.

**General note on configuration group 3**

Exiting from the configuration group 3 the instrument automatically tests the "SPLt" parameter (Split range [C.F01]). When "SPLt." parameter is enabled (= "Enb"), the instrument performs the following actions:

- 1) If "Añ.UL" parameter ("Output value for AUTO to MAN transfer [C.G04]) is lower than 0, it will be forced to "buñ".
- 2) If the "SF.UL" parameter ("Output safety value" [C.G08]) is lower than zero, it will be forced to zero.
- 3) If the "IP" parameter ("Integral pre-load" [r.d05]) is lower than zero, it will be forced to 50.0.

CnF. 3

CnF. 4

**CONFIGURATION GROUP 4 [C.Gxx]**  
AUXILIARY CONTROL CONFIGURATION

CnF.4

ACCn

**SnFn** - Smart function - [C.G01]

This parameter will be available only when at least one control output is configured

Range: dIS = Smart function disabled  
Enb = Smart function may be enabled

**CnEP** - Control action type - [C.G02]

This parameter will be available only when at least one control output is configured

Range: Pid = The process is controlled by PID actions  
Pi = The process is controlled by PI actions

**nAnF** - Manual function - [C.G03]

This parameter will be available only when at least one control output is configured

Range: dIS = Manual function disabled  
Enb = Manual function may be enabled

**AnUL** - Output value for AUTO to MAN transfer - [C.G04]

This parameter will be available only when at least one control output is configured and manual function is enabled ("nAn.F" [C.G03] = "Enb")

Range: - from 0.0 to 100.0 % of the output span if device is configured with only one control output  
- from -100.0 to 100.0 of the output span if device is configured with two control outputs (split range excluded).

Above the value 100.0 the display shows "buñ." meaning that the transfer from AUTO to MANUAL is bumpless (the instrument set for MANUAL mode the same power output used in AUTO mode)



**NOTES:**

- 1) When open loop servomotor control drive without valve position indication is configured, this parameter is forced to “buñ.” and it cannot be modified.
- 2) When open loop servomotor control drive with valve position indication is configured and the transfer from AUTO to MAN is required, the instrument is able to reach the value programmed by this parameter using temporarily the valve position value as a feedback.

**buñ.b** - MANUAL to AUTO transfer type - [C.G05]

This parameter will be available only when at least one control output is configured and manual function is enabled (“ñAn.F” [C.G03] = “Enb”)

Range: buñ. = Bumpless balance transfer  
buñ.b = Bumpless balancelless transfer (the operative set point is aligned to the measure value)

**NOTES:**

- 1) The “alignment” is not performed if measure is in error condition or Remote Set point is selected
- 2) The selected local set point will be changed even if it is software protected.

**SLFn** - Device status at start up - [C.G06]

This parameter will be available only when at least one control output is configured and manual function is enabled (“ñAn.F” [C.G03] = “Enb”).

Range: Auto = It starts always in auto mode  
 ñan = It starts always in manual mode with power output set to 0  
 Cnd.A = It starts in the same way it was left prior to power shut down (if in manual mode the power output is set to 0)  
 Cnd.b = It starts in the same way it was left prior to power shut down (if in manual mode the power output will be equal to the last value prior to power shut down).

CnF. 4



**SF.Cn** - Condition for output safety value - [C.G07]

This parameter will be available only when at least one control output is configured.

Ranges:

- When no output is configured as open loop servomotor control, "SF.Cn" can be set as follows:
  - Std. = No safety value ("standard setting" see chapter ERROR MESSAGES).
  - Ov.Un = Safety value applied when the instrument detect an overrange or underrange condition of the main input.
  - OvEr = Safety value applied when the instrument detect an overrange condition of the main input.
  - Undr = Safety value applied when the instrument detect an underrange condition of the main input.
- When the open loop servomotor control is configured, "SF.Cn" can be set as follows:
  - Std. = No safety value ("standard setting" see chapter ERROR MESSAGES).
  - Cnd.A = When the instrument detects an overrange or underrange condition of the main input, the servomotor is driven to its high limit position.
  - Cnd.b = When the instrument detects an overrange or

underrange condition of the main input, the servomotor is driven to its low limit position.

- Cnd.C = When the instrument detects an overrange or underrange condition of the main input, the action on servomotor is the complement of "standard" setting.

**SF.Ul** - Output safety value - [C.G08]

This parameter will be available only when "SF.Cn" [C.G07] is equal to "Ov.Un", "OvEr" or "Undr" or the parameter "A.I.Sc" ("Auxiliary input safety condition" [C.d15]) is equal to "Cnd.A"

Range:

- from 0.0 to 100.0 if device is configured with one control output;
- from -100.0 to 100.0 if device is configured with two control outputs (split range excluded).



**CONFIGURATION GROUP 5 [C.Hxx]**  
DIGITAL INPUT/OUTPUT CONFIGURATION

CnF.5

InDt

**IFn** - Logic input 1 function - [C.H01]

- Range: nonE = Input contact not used  
 SP1.2 = Input contact used for SP /SP2 set point selection (see note 2)  
 SP3.4 = Input contact used for SP3/SP4 set point selection (see note 2)  
 SP.L.r = Input contact used for Local/Remote set point selection (Remote when logic level is "1")  
 Au.nA = Input contact used for Auto/Manual selection (Manual when logic level is "1")  
 O.LIn = Input contact used for output limiter activation (Output limited when logic level is "1")  
 Hold = Input contact used to stop input sampling (Hold function) (Stop sampling when logic level is "1")

- n.rSt = Input contact used to reset (acknowledge) alarm (Reset when logic level is "1")  
 rE.dr = Input contact used for Reverse/Direct control action selection (Direct when logic level is "1")

**NOTES:**

- When logic input circuits are not mounted the middle display will show "no.Pr" (not present).
- When one logic input is set to "SP.1.2" and no other logic input is set to "SP.3.4", the relation between the logic level and the selected set point is the following:  
 Logic level 0 = SP  
 Logic level 1 = SP2

When one logic input is set to "SP.1.2" and a second logic input is set to "SP.3.4", the relation between the logic levels and the selected set point is the following:

"SP.3.4" level	"SP.1.2" level	Set point selected
0	0	SP
0	1	SP2
1	0	SP3
1	1	SP4

CnF.5

When one logic input is set to "SP.3.4" and no other logic input is set to "SP.1.2", the relation between the logic level and the selected set point is the following:

Logic level 0 = SP  
Logic level 1 = SP3

#### **d1.Fn** - Logic input 1 contact status - [C.H02]

This parameter will be available only when "d1.Fn" [C.H01] is different from "nonE".

Range: CLSd = The input is at logic level "1" when contact is closed  
OPEn = The input is at logic level "1" when contact is open

#### **d2.Fn** - Logic input 2 function - [C.H03]

This parameter will be available only when input contact option is fitted.

Range: nonE = Input contact not used  
SP1.2 = Input contact used for SP /SP2 set point selection (see note 2)  
SP3.4 = Input contact used for SP3/SP4 set point selection (see note 2)  
SP.L.r = Input contact used for Local/Remote set point selection (Remote when logic level is "1")  
Au.nA = Input contact used for Auto/Manual selection (Manual when logic level is "1")  
O.LIn = Input contact used for output limiter activation (Output limited when logic level is "1")  
Hold = Input contact used to stop input sampling (Hold function) (Stop sampling when logic level is "1")  
n.rSt = Input contact used to reset (acknowledge) alarm (Reset when logic level is "1")  
rE.dr = Input contact used for Reverse/Direct control action selection (Direct when logic level is "1")

**NOTE:** See also NOTE 2) of the "d1.Fn" ("Logic input 1 function" [C.H01]) parameter.

**d2St** - Logic input 2 contact status - [C.H04]

This parameter will be available only when "d2.Fn" [C.H03] is different from "nonE".

Range: CLSd = The input is at logic level "1" when contact is closed  
OPEn = The input is at logic level "1" when contact is open

**d3Fn** - Logic input 3 function - [C.H05]

This parameter will be available only when input contact option is fitted.

Range: nonE = Input contact not used  
SP1.2 = Input contact used for SP /SP2 set point selection (see note 2)  
SP3.4 = Input contact used for SP3/SP4 set point selection (see note 2)  
SP.L.r = Input contact used for Local/Remote set point selection (Remote when logic level is "1")  
Au.nA = Input contact used for Auto/Manual selection (Manual when logic level is "1")  
O.Liñ = Input contact used for output limiter activation (Output limited when logic level is "1")

Hold = Input contact used to stop input sampling (Hold function) (Stop sampling when logic level is "1")  
ñ.rSt = Input contact used to reset (acknowledge) alarm (Reset when logic level is "1")  
rE.dr = Input contact used for Reverse/Direct control action selection (Direct when logic level is "1")

**NOTE:** See also NOTE 2) of the "d1.Fn" ("Logic input 1 function" [C.H01]) parameter.

**d3St** - Logic input 3 contact status - [C.H06]

This parameter will be available only when "d3.Fn" [C.H05] is different from "nonE".

Range: CLSd = The input is at logic level "1" when contact is closed  
OPEn = The input is at logic level "1" when contact is open

CnF.5

**E1Fn** - Event 1 function - [C.H07]

This parameter will be available only when OUT 1 is configured as event annunciator ("O1.Fn" [C.E01] is equal to "Eun.1").

- Range:  $\bar{n}$ .In.E= Error condition (Over-Under-Open-Shrt) on main input (Logic level "1" when error occurs)  
 Cj.Er = Error condition on CJ measurement (Logic level "1" when error occurs)  
 A.In.E= Error condition (Over-Under-Open) on auxiliary input (Logic level "1" when error occurs)  
 $\bar{n}$ EA.E = Error condition on any measurement (Logic level "1" when error occurs)  
 Au. $\bar{n}$ A = Auto/manual mode annunciator (Logic level "1" when device is in manual mode)  
 SP.L.r = Local/Remote set point annunciator (Logic level "1" when remote set point is used)

**E1SL** - Event 1 contact status - [C.H08]

This parameter will be available only when OUT 1 is configured as event annunciator ("O1.Fn" [C.E01] is equal to "Eun.1").

- Range: CLSd = The output is at logic level "1" when contact is closed  
 OPEn = The output is at logic level "1" when contact is open

**E2Fn** - Event 2 function - [C.H09]

This parameter will be available only when OUT 2 is configured as event annunciator ("O2.Fn" [C.E02] is equal to "Eun.2").

- Range:  $\bar{n}$ .In.E= Error condition (Over-Under-Open-Shrt) on main input (Logic level "1" when error occurs)  
 Cj.Er = Error condition on CJ measurement (Logic level "1" when error occurs)  
 A.In.E= Error condition (Over-Under-Open) on auxiliary input (Logic level "1" when error occurs)  
 $\bar{n}$ EA.E = Error condition on any measurement (Logic level "1" when error occurs)

Au.ñA = Auto/manual mode annunciator (Logic level "1" when device is in manual mode)  
SP.L.r = Local/Remote set point annunciator (Logic level "1" when remote set point is used)

#### **E2.5t** - Event 2 contact status - [C.H10]

This parameter will be available only when OUT 2 is configured as event annunciator ("O2.Fn" [C.E02] is equal to "Eun.2").

Range: CLSd = The output is at logic level "1" when contact is closed  
OPEn = The output is at logic level "1" when contact is open

#### **E3.Fn** - Event 3 function - [C.H11]

This parameter will be available only when OUT 3 is configured as event annunciator ("O3.Fn" [C.E03] is equal to "Eun.3").

Range: ñ.In.E= Error condition (Over-Under-Open-Shrt) on main input (Logic level "1" when error occurs)  
Cj.Er = Error condition on CJ measurement (Logic level "1" when error occurs)  
A.In.E= Error condition (Over-Under-Open) on auxiliary input (Logic level "1" when error occurs)  
ñEA.E = Error condition on any measurement (Logic level "1" when error occurs)  
Au.ñA = Auto/manual mode annunciator (Logic level "1" when device is in manual mode)  
SP.L.r = Local/Remote set point annunciator (Logic level "1" when remote set point is used)

CnF.5

**E3.SL** - Event 3 contact status - [C.H12]

This parameter will be available only when OUT 3 is configured as event annunciator ("O3.Fn" [C.E03] is equal to "Eun.3").

Range: CLSd = The output is at logic level "1" when contact is closed

OPEn = The output is at logic level "1" when contact is open

**E4.Fn** - Event 4 function - [C.H13]

This parameter will be available only when OUT 4 is configured as event annunciator ("O4.Fn" [C.E04] is equal to "Eun.4").

Range: ñ.In.E= Error condition (Over-Under-Open-Shrt) on main input (Logic level "1" when error occurs)

Cj.Er = Error condition on CJ measurement (Logic level "1" when error occurs)

A.In.E= Error condition (Over-Under-Open) on auxiliary input (Logic level "1" when error occurs)

ñEA.E = Error condition on any measurement (Logic level "1" when error occurs)

Au.ñA = Auto/manual mode annunciator (Logic level "1" when device is in manual mode)

SP.L.r = Local/Remote set point annunciator (Logic level "1" when remote set point is used)

**E4.SL** - Event 4 contact status - [C.H14]

This parameter will be available only when OUT 4 is configured as event annunciator ("O4.Fn" [C.E04] is equal to "Eun.4").

Range: CLSd = The output is at logic level "1" when contact is closed

OPEn = The output is at logic level "1" when contact is open



**General notes on configuration group 5**

- 1) Digital input function selection should be “consistent” with other configuration parameters otherwise this digital input will remain unused.
- 2) Changing menu the device will check that the same function is not assigned to more than one digital input, otherwise the display will show:

CnF.5  
Err  
InDt.

**CONFIGURATION GROUP 6 [C.Ixx]**  
OTHERS CONFIGURATION PARAMETERS

CnF.6

DEHr

**GbrG** - Green bargraph function - [C.I01]

This parameter will be available for MKC models only.  
Range: Pr.Ur = the green bargraph will show the process variable value  
DEV. = the green bargraph will show the deviation (measured value minus set point)

**OrbG** - Orange bargraph function - [C.I02]

This parameter will be available for MKC models only.  
Range: OP.SP= On bargraph is shown the operative set point value  
P.Out. = On bargraph is shown the process output value

CnF. 6



**brIL** - Bargraph initial scale value - [C.I03]

This parameter will be available only for MKC models when "G.brG" [C.I01] is equal to "Pr.Ur" and/or "O.brG" [C.I02] is equal to "OP.SP".

Range: From "ñ.In.L" ("Read-out initial scale value" [C.d05]) to "ñ.In.H" ("Read-out full scale value [C.d06])

**brFH** - Bargraph full scale value - [C.I04]

This parameter will be available only for MKC models when "G.brG" [C.I01] is equal to "Pr.Ur" and/or "O.brG" [C.I02] is equal to "OP.SP".

Range: From "ñ.In.L" ("Read-out initial scale value" [C.d05]) to "ñ.In.H" ("Read-out full scale value [C.d06])

**brCd** - Resolution of the deviation bargraph - [C.I05]

This parameter will be available only for MKC models when "G.brG" [C.I01] is equal to "DEV.".

Range: 1-2-5-10-20 or 50 = Digits per segment

**SPAL** - Operative set point alignment at start up - [C.I06]

Range: ALG = At start up the operative set point is aligned to measure value and then it will reach the selected set point with the programmed ramp ("Grd1" [r.E14] and "Grd2" [r.E15]).

n.ALG = At start up the operative set point is equal to the selected set point

**NOTE:**The "ALG" selection has no effect when the measure is in error condition or Remote Set point is selected.



**SP.DS** - Set point display type - [C.I07]

Range: Fn.SP = When device is in normal display mode and it is performing a set point ramp, the middle display will show the final set point value.

OP.SP= When device is in normal display mode and it is performing a set point ramp, the middle display will show the operative set point value.

**NOTE:** This selection has effect only when local set points are used

**Sr.bH** - Servomotor behaviour when the output power is limited - [C.I08]

This parameter will be available only when the close loop servomotor control drive is configured

Range: bAL = When the PID output reaches the specific output limits ("Main control output low limit" [r.E04] or "Main control output high limit" [r.E05] or "Secondary control output low limit" [r.E08] or "Secondary control output high limit" [r.E09]) the instrument will reach the respective limit and than it will maintain the output relay in open condition.

n.bAL = When PID value is higher than "Main control output high limit" [r.E05] or "Secondary control output high limit" [r.E09] the OUT 3 (▲) relay contact is ever closed.  
When PID value is lower than "Main control output low limit" [r.E04] or "Secondary control output low limit" [r.E08] the OUT 4 (▼) relay contact is ever closed.

**SSLH** - Input threshold to enable the soft start - [C.I09]

Range: for TC/RTD ranges - within the input range;  
for linear input - within "ñ.In.L" ("Read-out initial scale value" [C.d05]) and "ñ.In.H" ("Read-out full scale value" [C.d06]).

**NOTE:** At start up if the measured value is lower than threshold value, the device maintains the output power limiting ("ñ.OLL" [r.E04], "ñ.OLH" [r.E05], "S.OLL" [r.E08] and "S.OLH" [r.E09]) for a programmed time ("tOL" [rE.16]).  
This function is called "soft start"

This threshold value has no effect if "tOL" [rE.16] = InF or when one logic input is configured for output limiter activation

Crit. 6

**EdwE** - Time out selection - [C.I10]

Range: tñ.10 = 10s time out  
tñ.30 = 30s time out

**NOTE:** for more details see "NOTE 2" at page 26.

**FdFn** - Out failure detection (OFD) - [C.I11]

This parameter will be available only when the option is fitted and the main and/or the secondary output is configured as time proportional control output

Range: nonE = Function not provided

ñC.On = Set "Fd.Fn" to "ñC.On" when the load under test is energized during the ON status of the main output (relay energized or SSR output status 1).

ñC.OF = Set "Fd.Fn" to "ñC.OF" when the load under test is energized during the OFF status of the main output (relay de-energized or SSR output status 0).

SC.On = Set "Fd.Fn" to "SC.On" when the load under test

is energized during the ON status of the secondary output (relay energized or SSR output status 1).

SC.OF = Set "Fd.Fn" to "SC.OF" when the load under test is energized during the OFF status of the secondary output (relay de-energized or SSR output status 0).

**NOTE:** When the option is not fitted the middle display will show "no.Pr"

**FdHS** - Primary current of the current transformer - [C.I12]

This parameter will be available only when "Fd.Fn" [C.I11] is different from "nonE"

Range: From 10 A to 100 A

**FdOut** - Out failure detection - output assignment  
- [C.113]

This parameter will be available only when "Fd.Fn" [C.111] is different from "nonE"

Range: nonE = The "Out failure detection" alarm is signalled only on display

OUT.1 = The "Out failure detection" alarm is signalled on OUT 1

OUT.2 = The "Out failure detection" alarm is signalled on OUT 2

OUT.3 = The "Out failure detection" alarm is signalled on OUT 3

OUT.4 = The "Out failure detection" alarm is signalled on OUT 4

**NOTE:** "Out failure detection" alarm annunciator cannot be assigned to an output just configured as control output.

**CONFIGURATION GROUP 7 [C.Lxx]**  
INPUT/OUTPUT TEST

*HErF*

*inOt.*

This group is displayed only when configuration modify mode is enabled.

This group allows you to verify the correct working of:

- the relay outputs (OUT 1 up to OUT4),
- digital inputs (diG.1 up to diG.3),
- the inputs from In1 up to In8 and the relays of the outputs from OUT10 up to OUT19, if the optional I/O card is fitted.

When an output is in "On" status, the related LED will light up

CnF.7

**C.L01 OUT 1 status**

Upper display: VErF

Lower display: OU.1

Range: On = Output enabled (relay energized)  
OFF = Output disabled (relay deenergized)**NOTE:** By pushing the ▲ or ▼ key it is possible to change the output state. The setting above described is the same for the remaining outputs.**C.L02 OUT 10 status**

This parameter is available only if the optional card is fitted.

Upper display: VErF

Lower display: OU.10

Range: On = Output enabled (relay energized)  
OFF = Output disabled (relay deenergized)**NOTE:** By pushing the ▲ or ▼ key it is possible to change the output state. The setting above described is the same for the remaining outputs.**C.L03 Digital input dIG.1 status**

Upper display: VErF

Lower display: dIG.1

Range: Open = Input open  
CLSd = Input closed**NOTE:** The setting above described is the same for the remaining inputs.**C.L04 Digital input In.1 status**

This parameter is available only if the optional card is fitted.

Upper display: VErF

Lower display: In.1

Range: Open = Input open  
CLSd = Input closed**NOTE:** The setting above described is the same for the remaining inputs.

**General note for configuration group "VErF"**

Returning in the "run time mode", the instrument restarts to control the process, the settings performed into this group do not affect the working settings.

**CONFIGURATION GROUP END [C.Lxx]**

END CONFIGURATION

This group will be displayed only when configuration modify mode is enabled.

*CONF*

*End.*

Range: nO = with this selection the instrument comes back to the first display of the configuration modify mode

YES = this selection terminate the configuration modify mode; the instrument performs an automatic reset and restarts the run time mode.

Pushing "▲" or "▼" push-button select the desired action and then push "MENU" push-button.

Conf. END

### RUN TIME MODE

If V101 is correctly set (see "Operative mode and hardware lock" at pag. 22), and the configuration mode has been terminated, the instrument will be in run time mode and in "normal display mode" (see below).

During run time mode the instrument performs the loop control and manages all the instrument functions (SMART, ALARMS, etc.).

### DISPLAY FUNCTION

When device is powered and is operating in automatic mode, the upper display shows the process variable (the value will be flashing if device is in hold status) and the middle display shows the set point value (final or operative according to "SP.dS" [C.107] parameter setting).

We define the above condition as "normal display mode".

The lower display will show:

- a) at instrument start up, the control output value (the LED % is lighted).

### NOTES:

In accordance with the configured output type, the control output can be displayed in the following ways:

- a.1) If the device is configured with servomotor control drive only, the feedback position value is displayed in the range -19.0 % to 120.0 % (the display is blank if open loop servomotor without valve position indication has been programmed)
- a.2) If the device is configured with one control output (linear or time proportional), the control output value is displayed in the range 0 % to 100 %.
- a.3) if the device is configured with two control outputs the value of the MAIN output is shown on the two most significant digits while the value of the SECONDARY output is shown on the two less significant digits. The decimal point between the two values will be flashing.

**NOTE:** the graphic symbol "□ □" shows that the specific control output is  $\geq 100\%$ .

Whenever one of the two outputs is a servomotor type, the instrument shows, for this output, the feedback position instead of the output in percent.

b) push the FUNC push-button; the lower display will show " A." followed by the current consumed by the load under test when the load is in ON condition (see also "OUT failure detection").

c) Push FUNC push-button again, the lower display will show " b." followed by the leakage current running in the load under test when the load is in OFF condition (see also "OUT failure detection").

d) Push FUNC push-button again, the lower display will show " Fd." followed by the OUT failure detection alarm status:

OF = no alarm

AL (flashing) = alarm

AL (steady) = acknowledged alarm

e) Push FUNC push-button again, the lower display will show " ñ." followed by the MAIN control output value in the range 0.0 % (-19.0 % for feedback) to 99.9 % (" □ □ □ " shows that the control output is  $\geq 100.0$  %) or within the scale configured by "ñC.E.L" [C.F09] and "ñC.E.H" [C.F10].

**NOTE:** When the MAIN output is a servomotor type, the instrument shows, for this output, the feedback position instead of the output in percent.

f) Push FUNC push-button again, the lower display will show " S." followed by the SECONDARY control output value in the range 0.0 % (-19.0 % for feedback) to 99.9 % (" □ □ □ " shows that the control output is  $\geq 100.0$  %) or within the scale configured by "SC.E.L" [C.F15] and "SC.E.H" [C.F16].

**NOTE:** When the secondary output is a servomotor type, the instrument shows, for this output, the feedback position instead of the output in percent.

g) Push FUNC push-button again, the lower display will show the value of the auxiliary input, if configured.

- Pushing FUNC push-button again, the display will come back to the control output value indication.

All the seven types of visualization are not bound to a time out unless OFD (output failure detection) is in not acknowledged alarm condition.

In this situation, the instrument forces the indication described at point d) and, if a different indication is required, it restores this indication after time out (see "t.out" [C.110]).

#### NOTES:

- 1) The previous informations will be displayed only if the relative function has been previously configured.
- 2) After parameter modification or monitoring, the instrument comes back to the "normal display mode" with, on the lower display, the indication previously selected.

#### INDICATORS

- °C Lit when process variable is in Celsius degree.  
°F Lit when process variable is in Fahrenheit degree.  
ST Flashing when the first step of SMART algorithm is activated.  
Lit when the second step of SMART algorithm is activated.  
% Lit when the lower display shows the output power value.  
MAN Lit when device is in manual mode.  
REM Lit when device is controlled by serial link.  
RSP Lit when Remote Set point is used.  
SPX Lit when an auxiliary Set point (SP2, SP3 or Sp4) is used.  
Flashing when a temporary set point, from serial link, is used.

- 1 Lit when OUT 1 is used as control output and it is in ON condition or when Event 1 is at logic level 1 or when alarm 1 is in alarm state and acknowledged.  
Flashes when alarm 1 is in alarm state and it is not acknowledged.
- 2 Lit when OUT 2 is used as control output and it is in ON condition or when Event 2 is at logic level 1 or when alarm 2 is in alarm state and acknowledged.  
Flashes when alarm 2 is in alarm state and it is not acknowledged.
- 3 Lit when OUT 3 is used as control output and it is in ON condition or when servomotor output increases or when Event 3 is at logic level 1 or when alarm 3 is in alarm state and acknowledged.  
Flashes when alarm 3 is in alarm state and it is not acknowledged.
- 4 Lit when OUT 4 is used as control output and it is in ON condition or when servomotor output decreases or when Event 4 is at logic level 1 or when alarm 4 is in alarm state and acknowledged.  
Flashes when alarm 4 is in alarm state and it is not acknowledged.



### BARGRAPH DESCRIPTION

On MKC model only, two 33 LED's bargraphs are available.

On the right bargraph, with orange LED's, it is possible to show:

- the operative set point scaled as configured by "brG.L" [C.I03] and "brG.H" [C.I04].

The "SP" LED, located on the base of the bargraph, is lighted.

- the power output value.

The "%" LED, located on the top of the bargraph, is lit.

When the device has two process outputs, the central LED (which is a two-color LED) become green. It divides the bargraph into two parts: the MAIN process output is shown on the upper part while the SECONDARY process output is shown on the lower part.

If a process output is a servomotor type, the bargraph will show the valve position instead of the power output (the first or last LED's is flashing when the feedback position is out of range 0÷100).

On the left bargraph, with green LED's, it is possible to show:

- the process variable scaled as configured by "brG.L" [C.I03]

and "brG.H" [C.I04].

The "PV" LED, located on the base of the bargraph, is lit.

- The deviation error (PV - SP) with resolution configured at "brG.d" [C.I05].

The "DEV" LED, located on the top of the bargraph, is lit.

When the deviation error indication is selected, the central LED (which is a two-color LED) become orange. It divides the bargraph into two parts: the positive error is shown on the upper part while the negative error is shown on the lower part. The last LED will flash if deviation is out of range.

#### **OUT FAILURE DETECTION FUNCTION (OFD)**

The device is capable to measure and display:

- the current running in a load driven by a time proportional control output (main or secondary programmable) when the load is energized;
- the leakage current flowing through the load when the load is de-energized.

If the instrument has been correctly set, it generates an alarm when:

- the current running in the load (when the load is energized) is lower than the "A.L.Fd" [r.C14] parameter value (It shows a partial or total break down of the load, the break down of the actuator or a power down due to a protection or a fuse intervention);
- the leakage current (when the load is de-energized) is higher than the "A.H.Fd" [r.C15] parameter value (It shows a short circuit of the actuator).

The "Display function" paragraph describes how to show the two current values.

The fault condition is shown on the lower display by the "Fd.AL" indication ("AL" may be flashing or steady on in accordance with acknowledge condition) and by the status of the assigned output.

If the ON or OFF period is lower than 120 ms the relative measurement couldn't be performed and the instrument will show flashing the last measured value.

#### **DIRECT ACCESS TO THE SET POINT**

When the device is in AUTO mode and in "Normal Display Mode", it is possible to access directly to the selected set point modification (SP, SP2, SP3 or SP4).

Pushing ▲ or ▼ for more than 2 s, the set point will begin changing.

The new set point value becomes operative since no push-button has been depressed at the end of 2 s time out.

The direct access to the set point is disabled if the run time group 1 is software protected or remote set point is used.

### MANUAL FUNCTION

The MANUAL mode function can be accessed (only if configured) by depressing the MAN push-button for more than 1 sec or by acting on a logic input configured as "Au.nA" (auto/manual selection).

The command from keyboard is accepted and executed only if the instrument is in "Normal Display Mode" while the command from logic input is always accepted.

When in MANUAL mode the LED's MAN light up while the middle display shows "n." followed by the main output values (from 0.0 to 99.9%) and the lower display shows "S." followed by the secondary output value (from 0.0 to 99.9%).

When the device is configured with one control output only and this output is "Servo", the display will show the current valve position.

When the device has two control outputs and one of them is "Servo", during valve positioning the display will show the final position of the valve and not the current position.

The control output and/or the feedback position can be modified by using "▲" and "▼".

To come back to the AUTO mode, depress "MAN" push-button for more than 1 sec. or toggle the logic input.

The transfer from AUTO to MANUAL is bumpless (this function is not provided if an output value has been selected at configuration parameter "Añ.UL" [C.G04]).

The transfer from MANUAL to AUTO is bumpless or bumpless balanceless (the bumpless feature is not provided if integral action is excluded).

If transfer from AUTO to MANUAL is performed during the first part of SMART algorithm (TUNE) when returning in AUTO the device will be forced automatically in the second part of the SMART algorithm (ADAPTIVE).

At power up the device starts as configured at "St.Fn" [C.G06] configuration parameter.

### NOTES:

1) When auto/manual control mode is selected by logic input, at power up the instrument will start in accordance with the logic input status.

If the logic input status requires the manual mode, the instrument will verify the "St.Fn" [C.G06] parameter setting and if "St.Fn" [C.G06] is equal to "Auto", "ñan" or "Cnd.A" the power output will be set to zero otherwise the power output will be set equal to the last value prior to power shut down.

2) If the instrument is configured for one control output, the control output is a servo motor type (close or open loop) and device starts up in manual mode, the following action may occur:

2.A) The valve remains in the same position if:

"St.Fn" [C.G06] = "ñan" or  
"St.Fn" [C.G06] = "Cnd.A" or  
"St.Fn" [C.G06] = "Cnd.b" and "Añ.UL" [C.G04] = "buñ."

2.B) The valve will be moved to the value set in "Añ.UL" if  
"St.Fn" [C.G06] = "Cnd.b" and "Añ.UL" [C.G04] is  
different from "buñ."

### SERIAL LINK

The device can be connected to a host computer by a serial link. The host can put the device in LOCAL (functions and parameters are controlled via keyboard) or in REMOTE (functions and parameters are controlled via serial link).

The REMOTE status is signalled by the REM LED.

This instrument allows to modify the operative and configuration parameters, via serial link.

The necessary conditions to implement this function are the following:

- 1) the serial parameters (see Run time group 7) should be properly configured.
- 2) the device must be in the run time mode.
- 3) when it is desired to modify configuration parameter, the dip switch V101.3 should be set to "OFF" (configuration parameter enabled)

During configuration parameter downloading the device goes in open loop with all output in OFF state.

At the end of configuration procedure, the device performs an automatic reset and then returns to close loop control.

### LAMP TEST

When it is desired to verify the display efficiency, put the instrument in "normal display mode" and push ▼ and MENU push-buttons for more than 5 s.

The instrument will turn ON, with a 50 % duty cycle, all the LEDs of the display (we define this function "LAMP TEST").

No time out is applied to the LAMP TEST.

When it is desired to come back to the normal display mode, push any push-button.

During the LAMP TEST the instrument continues to control the process.

### SMART FUNCTION

It is used to automatically optimize the control action.

To enable the SMART function proceed as follows:

- 1) push the MENU push-button until "Gr. 2" run time parameter group is shown.
- 2) push the FUNC push-button until "Sñrt" parameter is shown.
- 3) push ▲ or ▼ and set the "On" indication on the middle display;
- 4) push the FUNC push-button.

The ST LED will turn on or flashing according to the selected algorithm.

When the smart function is enabled, it is possible to display but not to modify the control parameters.

To disable the SMART function proceed as follows:

- 1) push the MENU push-button until "Gr. 2" run time parameter group is shown.
- 2) push the FUNC push-button until "Sñrt" parameter is shown.
- 3) push ▲ or ▼ and set the "OFF" indication on the middle display;
- 4) push the FUNC push-button.

The ST LED will turn off.

The instrument maintains the current set of control parameters and it enables parameter modification.

- NOTES :**
- 1) When ON/OFF control is programmed (Pb=0), the SMART function is disabled.
  - 2) The SMART enabling/disabling can be protected by safety key.

### HOLD FUNCTION

By means of an logic input it is possible to stop the inputs sampling keeping frozen the last measure values (main and auxiliary input).

During measuring hold the instrument will continue to control the process using the last measured values and the following functions will be inhibited:

- 1) Local set point to remote set point transfer and viceversa
- 2) Manual to auto mode transfer

**NOTE:** The auto to manual transfer is allowed  
The measure value on the upper display will be flash to indicate the hold status

### PARAMETER PROTECTION

Moving from one run time parameter group to another, the instrument will show, at first, the group number (on the upper display), the mnemonic code (on the lower display) and the security status (on the middle display) of the group.

The possible security status are:

Enb = the parameters of this group are not protected and they may be modified;

inh = the parameters of this group are ever protected and they cannot be modified

---- = the parameters of this group are software protected.  
In this case, using "▲" and "▼" push-button set a value equal to the security code programmed during the "Run time security code " (see page 23) and then push "FUNC".

If the programmed value matches the security code the parameters of this group can be modified otherwise they remain protected.

**ATTENTION:** One software key protects one or more run time parameter groups so that when the software key is inserted, it is possible to modify the run time parameters of all groups. The software protection will be automatically restored when the instrument comes back to the "normal display mode" (by "MENU" push-button pressure or by the time out).

### RUN TIME PARAMETER MODIFICATION.

By "MENU" push-button it is possible to start the run time parameter modification by selecting desired run time parameter group.

During the run time parameter modification, the upper display shows the selected parameter group, the lower display shows the mnemonic code of the selected parameter while the central display shows the value or status assigned to the selected parameter.

The parameter monitoring and modification are subjected to a time out (see "t.out" [C.110] parameter) after that the display returns in "Normal display mode" and the eventual modification on the last displayed parameter will be lost.

#### NOTES:

- 1) In the following pages we will describe all the parameter of the instrument but it will show only the parameters related with the specific hardware and in accordance with the specific instrument configuration.
- 2) If all the parameters of a group are not available, the instrument will not display this group.
- 3) For an easy consultation of the manual, it is accompanied by a table with all the run time parameter visualization.

### Run time group 1 [r.Axx] Set point VALUES

Gr. 1  
-----  
SPn

**SP** - Main set point - [r.A01]

Range: from "rL" [r.E12] to "rH" [r.E13].

**SP2** - Set point 2 - [r.A02]

This parameter is available only when one of the logic inputs is configured for SP/SP2 selection

Range: from "rL" [r.E12] to "rH" [r.E13].

Gr.1

Gr.2

**SP3** - Set point 3 - [r.A03]

This parameter is available only when one of the logic inputs is configured for SP3/SP4 selection.  
Range: from "rL" [r.E12] to "rH" [r.E13].

**SP4** - Set point 4 - [r.A04]

This parameter is available only when one of the logic inputs is configured for SP/SP2 selection and another one for SP3/SP4 selection.  
Range: from "rL" [r.E12] to "rH" [r.E13].

**dFlt** - Group 1 default data loading - [r.A05]

Range: OFF = No loading data  
ON = Loading data

**Run time group 2 [r.bxx]**  
SMART ENABLE/DISABLE

Gr. 2  
-----  
Smart

**Smart** - SMART function - [r.b01]

This parameter is available when at least one control output is configured and SMART function is enabled ("Sñ.Fn" [C.G01]= "Enb")

Range: OFF = SMART algorithm is deactivated  
ON = SMART algorithm is activated

Set On or OFF to activate/deactivate the SMART algorithm.



**Run time group 3 [r.Cxx]**  
ALARM THRESHOLD AND HYSTERESIS VALUE

Gr. 3  
-----  
ALrñ

**ñrSt** - Manual reset of the alarms - [r.C01]

Range: ON/OFF  
Change to ON and then depress "FUNC" key to reset/  
acknowledge the alarm condition.

**NOTES:**

- 1) The reset/acknowledge function is always enabled.
- 2) When one of the logic input is configured as alarm reset, both actions (of "ñ.rSt" parameter and of the logic input) are active.

**AL1** - Alarm 1 threshold - [r.C02]

This parameter is available when alarm 1 is configured as process, deviation, main power output or secondary power output alarm ("A1.tP" [rF.01] = "Proc" or "dEV" or "ñAin" or "SECn")

Range: - in engineering units within the span limits for process alarm;  
- from -1000 to 1000 digits for deviation alarm;  
- from 0.0% to 100.0 % for control output alarm.

**NOTE:** The span limits are configured by "ñ.In.L" [C.d05] and "ñ.In.H" [C.d06].

**baL** - Low threshold used when the alarm 1 is a band alarm - [r.C03]

This parameter is available only when the alarm 1 is configured as band alarm ("A1.tP" [rF.01] = "bAnd")

Range: from 0 to -1000 digits.

Gr.3

**BA1H** - high threshold used when the alarm 1 is a band alarm - [r.C04]

This parameter is available only when the alarm 1 is configured as band alarm ("A1.tP" [rF.01] = "bAnd")

Range: from 0 to 1000 digits.

**NOTE:** The "bA1.L" and "bA1.h" values are algebraically added to the operative set point in order to obtain the band limits.

**AL2** - Alarm 2 threshold - [r.C05]

This parameter is available when alarm 2 is configured as process, deviation, main power output or secondary power output alarm ("A2.tP" [rF.05] = "Proc" or "dEV" or "nAin" or "SECh")

Range: - in engineering units within the span limits for process alarm;  
- from -1000 to 1000 digits for deviation alarm;  
- from 0.0% to 100.0 % for control output alarms.

**NOTE:** The span limits are configured by "n.In.L" [C.d05] and "n.In.H" [C.d06].

**BA2L** - Low threshold used when the alarm 2 is a band alarm - [r.C06]

This parameter is available only when the alarm 2 is configured as band alarm ("A2.tP" [rF.05] = "bAnd")

Range: from 0 to -1000 digits.

**BA2H** - high threshold used when the alarm 2 is a band alarm - [r.C07]

This parameter is available only when the alarm 2 is configured as band alarm ("A2.tP" [rF.05] = "bAnd")

Range: from 0 to 1000 digits.

**NOTE:** The "bA2.L" and "bA2.h" values are algebraically added to the operative set point in order to obtain the band limits.

**AL3** - Alarm 3 threshold - [r.C08]

This parameter is available when alarm 3 is configured as process, deviation, main power output or secondary power output alarm ("A3.tP" [rF.09] = "Proc" or "dEV" or "ñAin" or "SECn")

Range: - in engineering units within the span limits for process alarm;

- from -1000 to 1000 digits for deviation alarm;
- from 0.0% to 100.0 % for control output alarms.

**NOTE:** The span limits are configured by "ñ.In.L" [C.d05] and "ñ.In.H" [C.d06].

**bA3L** - Low threshold used when the alarm 3 is a band alarm - [r.C09]

This parameter is available only when the alarm 3 is configured as band alarm ("A3.tP" [rF.09] = "bAnd")

Range: from 0 to -1000 digits.

**bA3H** - high threshold used when the alarm 3 is a band alarm - [r.C10]

This parameter is available only when the alarm 3 is configured as band alarm ("A3.tP" [rF.09] = "bAnd")

Range: from 0 to 1000 digits.

**NOTE:** The "bA3.L" and "bA3.h" values are algebraically added to the operative set point in order to obtain the band limits.

**AL4** - Alarm 4 threshold - [r.C11]

This parameter is available when alarm 4 is configured as process, deviation, main power output or secondary power output alarm ("A4.tP" [rF.13] = "Proc" or "dEV" or "ñAin" or "SECn")

Range: - in engineering units within the span limits for process alarm;

- from -1000 to 1000 digits for deviation alarm;
- from 0.0% to 100.0 % for control output alarms.

**NOTE:** The span limits are configured by "ñ.In.L" [C.d05] and "ñ.In.H" [C.d06].

Gr.3

**bA4L** - Low threshold used when the alarm 4 is a band alarm - [r.C12]

This parameter is available only when the alarm 4 is configured as band alarm ("A4.tP" [rF.13] = "bAnd")  
Range: from 0 to -1000 digits.

**bA4H** - high threshold used when the alarm 4 is a band alarm - [r.C13]

This parameter is available only when the alarm 4 is configured as band alarm ("A4.tP" [rF.13] = "bAnd")  
Range: from 0 to 1000 digits.

**NOTE:** The "bA4.L" and "bA4.h" values are algebraically added to the operative set point in order to obtain the band limits.

**ALFd** - Output failure detection low alarm threshold - [r.C14]

This parameter is available only when the option is present and "Fd.Fn" [C.I10] is equal to "ñC.On" or "ñC.OF" or "SC.On" or "SC.OF".

Range: from 0 to "Fd.HS" [C.I12].

**NOTES:**

- 1) The device is in alarm status when the current, measured during the ON status of the load, is lower than this threshold.
- 2) The OFD (output failure detection) alarm threshold resolution values is equal to 0.1 A for range up to 25 A and 1 A for range up to 100 A
- 3) The hysteresis on this threshold values is fixed to 1% of fsv

**AHFd** - Output failure detection high alarm threshold - [r.C15]

This parameter is available only when the option is present and "Fd.Fn" [C.I10] is equal to "ñC.On" or "ñC.OF" or "SC.On" or "SC.OF".

Range: from 0 to "Fd.HS" [C.I12].

**NOTES:**

- 1) The device is in alarm status when the current, measured during the OFF status of the load (leakage current), is higher than this threshold.

- 2) The OFD (output failure detection) alarm threshold resolution values is equal to 0.1 A for range up to 25 A and 1 A for range up to 100 A
- 3) The hysteresis on this threshold values is fixed to 1% of fsv

**HSR1** - Alarm 1 hysteresis - [r.C16]

This parameter is available only when Out 1 is configured as alarm output ("O1.Fn" [C.E01] = "ALr.1")  
Range: from 1 to 200 digits

**HSR2** - Alarm 2 hysteresis - [r.C17]

This parameter is available only when Out 2 is configured as alarm output ("O2.Fn" [C.E02] = "ALr.2")  
Range: from 1 to 200 digits

**HSR3** - Alarm 3 hysteresis - [r.C18]

This parameter is available only when Out 3 is configured as alarm output ("O3.Fn" [C.E03] = "ALr.3")  
Range: from 1 to 200 digits

**HSR4** - Alarm 4 hysteresis - [r.C19]

This parameter is available only when Out 4 is configured as alarm output ("O4.Fn" [C.E04] = "ALr.4")  
Range: from 1 to 200 digits

**DEFL** - Group 3 default data loading - [r.C20]

Range: OFF = No loading data  
ON = Loading data

Gr.3

Run time group 4 [r.dxx]  
CONTROL PARAMETERS

Gr. 4  
-----  
Enter

Gr.4

**NOTE:** when SMART function is activated, all the parameters calculated by SMART (Pb, Ti, Td and rCG) can not be modified.

**Pb** - Proportional band - [r.d01]

This parameter is available when at least one control output is configured.

Range: from 0.5% to 999.0% of the input span.

Set 0.0% for On/OFF control action

**NOTES:**

- 1) The Pb resolution will be equal to 0.1% up to 10.0% and 1% up to 999.0.
- 2) When device is working with SMART algorithm the "Pb" value will be limited as selected by parameters "Pb.Hi" [r.L02] and "Pb.Lo" [r.L01]

**HY** - Hysteresis (for ON/OFF control) - [r.d02]

This parameter is available when Pb [r.d01]=0 (On/OFF control action)

Range: from 0.1% to 10.0% of the input span.

**TI** - Integral time - [r.d03]

This parameter is available when at least one control output is configured and Pb [r.d01] is different from 0.

Range: from 00.01 to 20.00 mm.ss

Above this value the display blanks and the integral action is excluded

**NOTE:** When device is working with SMART algorithm the "ti" value will be limited as selected by "ti.Hi" [r.L04] and "ti.Lo" [r.L03].

**td** - Derivative time - [r.d04]

This parameter is available when at least one control output is configured, "Cn.tP" [C.G02] is equal to "Pid" and "Pb" [r.d01] is different from 0.

Range: From 00.00 to 10.00 mm.ss

**NOTES:**

- 1) When device is working with SMART algorithm and "Cn.tP" [C.G02] is equal to "Pid", the "td" value will be made equal to a quarter of "ti" value.
- 2) When "Cn.tP" [C.G02] is equal to "Pi", the derivative action is excluded

**IP** - Integral preload - [r.d05]

This parameter is available when at least one control output is configured and "Pb" [r.d01] is different from 0.

Ranges:

- from 0.0 to 100.0 % of the output when device is configured with only one control output
- from -100.0 to 100.0 % of the output when device is configured with two control outputs (split range excluded)

**r.Gn** - Relative secondary output gain - [r.d06]

This parameter is available when two control outputs are configured (split range excluded) and "Pb" [r.d01] is different from 0.

Range: from 0.20 to 2.00

**OLAP** - Overlap/dead band between main and secondary outputs - [r.d07]

This parameter is available when two control outputs are configured (split range excluded) and "Pb" [r.d01] is different from 0.

Range: from -20 to 50

**NOTE:** A negative value means a dead band while a positive value means an overlap.

**Cn.AC** - Control action - [r.d08]

Range: rEv = reverse action  
dir = direct action

**Gr.5**

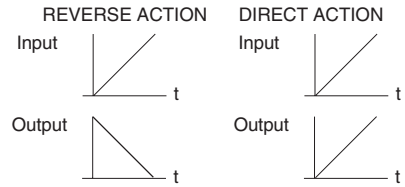

**NOTES:**

- 1) When device is configured with two control outputs (split range excluded) the control action is forced to reverse and it cannot be modify.
- 2) When direct/reverse selection is performed by a logic input this parameter allows you to monitor the current selected action only.

**Gr.4** - Group 4 default data loading - [r.d09]

Range: OFF = No loading data  
 ON = Loading data

**Run time group 5 [r.Exx]**

AUXILIARY CONTROL PARAMETER

Gr. 5  
 -----  
 ACTr

**Gr.4** - Anti reset wind up - [r.E01]

This parameter is available when at least one control output is configured and "Pb" [r.d01] is different from 0.  
 Range: from 10% to 200% of the input span

**Gr.4** - Servo motor travel time - [r.E02]

This parameter is available when the open loop servomotor control drive output is configured ("O3.Fn" [C.E03] is equal to "ñC.Sñ" or "SC.Sñ" and "Sñ.tP" [C.E05] are equal to "OPEn").  
 Range: from 0.12 to 3.00 m.ss



**Srdb** - Servo motor dead band - [r.E03]

This parameter is available when the servomotor control drive output is configured ("O3.Fn" [C.E03] is equal to "ñC.Sñ" or "SC.Sñ").  
Range: from 1% to 50%

**nOLL** - Main control output low limit - [r.E04]

This parameter is available when one control output is configured as main output.  
Range: from 0.0 % (of the output span) to ñ.OLH [r.E05]

**nOLH** - Main control output high limit - [r.E05]

This parameter is available when one control output is configured as main output.  
Range: from ñ.OLL [r.E04] to 100.0 % of the output span

**n.rnP** - Main control output max rate of rise - [r.E06]

This parameter is available when one control output is configured as main output.  
Ranges: from 0.1%/s to 25.0%/s.  
Above this value the display shows "Inf" meaning that no limit is imposed

**NOTES:**

- 1) This parameter will be active even if device is configured for On/OFF control.
- 2) During the transfert from AUTO to MANUAL, if this action is programmed as a not bumpless transfer, the "ñ.rnP" function will be ignored and the output will step up to the value set by "Añ.UL" [C.G04] parameter.

**nCCY** - Main output cycle time - [r.E07]

This parameter is available when time proportional main control output is configured.  
Range: from 1 to 200 s

Gr.5

**SOLL** - Secondary control output low limit - [r.E08]

This parameter is available when one control output is configured as secondary control output.

Range: From 0.0 % of the output span to S.OLH [r.E09].

**SOLH** - Secondary control output high limit - [r.E09]

This parameter is available when one control output is configured as secondary control output.

Range: from S.OLL [r.E08] to 100.0 % of the output span

**SrñP** - Secondary control output max rate of rise - [r.E10]

This parameter is available when one control output is configured as secondary control output.

Ranges: from 0.1%/s to 25.0%/s.

Above this value the display shows "Inf" meaning that no limit is imposed

**NOTES:**

- 1) This parameter will be active even if device is configured for On/OFF control.
- 2) During the transfer from AUTO to MANUAL, if this action is programmed as a not bumpless transfer, the "S.rñP" function will be ignored and the output will step up to the value set by "Añ.UL" [C.G04] parameter.

**SCCY** - Secondary output cycle time - [r.E11]

This parameter is available when a time proportional secondary control output is configured.

Range: from 1 to 200 s

**rL** - Set point low limit - [r.E12]

Range: From "ñ.In.L" [C.d05] to rH [r.E13].

**NOTES:** Whenever "ñ.In.L" [C.d05] has been modified, the following occurs:

- 1) rL will be realigned to it;
- 2) if the set point values are out of the new limits, the set point automatically assumes the default value.

**rH** - Set point high limit - [r.E13]

Range: from rL [r.E12] to "n.In.H" [C.d06].

**NOTES:** Whenever "n.In.H" [C.d06] has been modified, the following occurs:

- 1) rH will be realigned to it;
- 2) if the set point values are out of the new limits, "rH" automatically assumes the default value.

**Grd1** - Rate of change for positive set point variations - [r.E14]

Range: from 1 to 200 digits per minute.

Above this value the display shows "Inf" and the transfer will be a step change.

**Grd2** - Rate of change for negative set point variations - [r.E15]

Range: from 1 to 200 digits per minutes.

Above this value the display shows "Inf" and the transfer will be a step change.

**tOL** - Time out for the soft start - [r.E16]

This parameter is available when at least one output is configured as control output and no logic input is configured as "Output limiter activator".

Range: from 1 to 540 min.

Above this value the display shows "InF" and the limiting action is always active.

**NOTE:** The tOL can be always modified but the new value will be used only at the next device power up

Gr.5

**E.Añ** - External control for AUTO /MANUAL mode  
- [r.E17]

This parameter is available when one of the logic inputs is configured for Auto/Manual selection.

Range: On the Auto/Manual selection is made by logic input only  
OFF the Auto/Manual selection is made by "Man" key or serial link only

**E.Lr** - External control for local/remote set point selection - [r.E18]

This parameter is available when one of the logic inputs is configured for Local/Remote set point selection and "A.I.Añ" [C.d14] is equal to "norñ".

Range: On the local/remote set point selection is made by external contact only  
OFF the local/remote selection is made by "RSP" push-button or serial link only.

**E.rd** - External control for reverse/direct output action selection - [r.E19]

This parameter is available when one of the logic inputs is configured for direct/reverse output action selection.

Range: On the reverse/direct selection is made by external contact only  
OFF the reverse/direct selection is made by "Cn.Ac" [r.d08] parameter or serial link only.

**dFLE** - Group 5 default data loading - [r.E20]

Range: OFF = No loading data  
ON = Loading data

Run time group 6 [r.Fxx]  
ALARM SETTING

Gr. 6  
-----  
RSET

**ALP** - Alarm 1 type - [r.F01]

This parameter is available only when OUT 1 is configured as alarm 1 output ("O1.Fn" [C.E01] = "ALr.1")

Range: Proc = Alarm on process variable

bAnd = Band alarm on process variable

dEV = Deviation alarm on process variable

nAin = Alarm on Main control output value

SECn = Alarm on Secondary control output value

**NOTE:** When alarm type has been changed the alarm threshold will be forced to its default value and alarm status will be cleared.

**ALr** - Alarm 1 configuration - [r.F02]

This parameter is available only when OUT 1 is configured as alarm 1 output ("O1.Fn" [C.E01] = "ALr.1")

Range: H.A. = High alarm (outside band) with automatic reset

L.A. = Low alarm (inside band) with automatic reset

H.A.Ac= High alarm (outside band) with automatic reset and acknowledge

L.A.Ac= Low alarm (inside band) with automatic reset and acknowledge

H.L. = High alarm (outside band) with manual reset

L.L. = Low alarm (inside band) with manual reset

**NOTE:** When alarm configuration has been changed, the alarm status will be cleared.

Gr.6

**A1AC** - Alarm 1 action - [r.F03]

This parameter is available only when OUT 1 is configured as alarm 1 output ("O1.Fn" [C.E01] = "ALr.1")

Range: dir = direct action (Relay energized or SSR=1 in alarm condition)  
 rEV = Reverse action (Relay energized or SSR=1 in non alarm condition)

**A1SE** - Alarm 1 stand by (mask) function - [r.F04]

This parameter is available only when OUT 1 is configured as alarm 1 output ("O1.Fn" [C.E01] = "ALr.1")

Range: OFF = Stand-by function disabled  
 On = Stand-by function enabled

**NOTES:**

- 1) If the alarm is programmed as band or deviation alarm, this function masks the alarm condition after a set point change or at the instrument start-up until process variable reaches the alarm threshold plus or minus hysteresis. If the alarm is programmed as a process alarm or control output alarm, this function masks the alarm condition at instrument start-up until process variable reaches the alarm threshold plus or minus hysteresis.

- 2) The change from On to OFF has immediate effect, while the change from OFF to On has effect at the next start up or set point change.

**A2LP** - Alarm 2 type - [r.F05]

This parameter is available only when OUT 2 is configured as alarm 2 output ("O2.Fn" [C.E02] = "ALr.2")

Range: Proc = Alarm on process variable  
 bAnd = Band alarm on process variable  
 dEV = Deviation alarm on process variable  
 ñAin = Alarm on Main control output value  
 SECn = Alarm on Secondary control output value

**NOTE:** When alarm type has been changed the alarm threshold will be forced to its default value and alarm status will be cleared.

**A2Ln** - Alarm 2 configuration - [r.F06]

This parameter is available only when OUT 2 is configured as alarm 2 output ("O2.Fn" [C.E02] = "ALr.2")

Range: H.A. = High alarm (outside band) with automatic reset  
 L.A. = Low alarm (inside band) with automatic reset

- H.A.Ac= High alarm (outside band) with automatic reset and acknowledge
- L.A.Ac= Low alarm (inside band) with automatic reset and acknowledge
- H.L. = High alarm (outside band) with manual reset
- L.L. = Low alarm (inside band) with manual reset

**NOTE:** When alarm configuration has been changed, the alarm status will be cleared.

**A2AC - Alarm 2 action - [r.F07]**

This parameter is available only when OUT 2 is configured as alarm 2 output ("O2.Fn" [C.E02] = "ALr.2")

- Range: dir = direct action (Relay energized or SSR=1 in alarm condition)
- rEV = Reverse action (Relay energized or SSR=1 in non alarm condition)

**A2SL - Alarm 2 stand by (mask) function - [r.F08]**

This parameter is available only when OUT 2 is configured as alarm 2 output ("O2.Fn" [C.E02] = "ALr.2")

- Range: OFF = Stand-by function disabled
- On = Stand-by function enabled

**NOTES:**

- 1) If the alarm is programmed as band or deviation alarm, this function masks the alarm condition after a set point change or at the instrument start-up until process variable reaches the alarm threshold plus or minus hysteresis. If the alarm is programmed as a process alarm or control output alarm, this function masks the alarm condition at instrument start-up until process variable reaches the alarm threshold plus or minus hysteresis.
- 2) The change from On to OFF has immediate effect, while the change from OFF to On has effect at the next start up or set point change

Gr.6

**A3LP** - Alarm 3 type - [r.F09]

This parameter is available only when OUT 3 is configured as alarm 3 output ("O3.Fn" [C.E03] = "ALr.3")

Range: Proc = Alarm on process variable  
 bAnd = Band alarm on process variable  
 dEV = Deviation alarm on process variable  
 nAin = Alarm on Main control output value  
 SECn = Alarm on Secondary control output value

**NOTE:** When alarm type has been changed the alarm threshold will be forced to its default value and alarm status will be cleared.

**A3Ln** - Alarm 3 configuration - [r.F10]

This parameter is available only when OUT 3 is configured as alarm 3 output ("O3.Fn" [C.E03] = "ALr.3")

Range: H.A. = High alarm (outside band) with automatic reset  
 L.A. = Low alarm (inside band) with automatic reset  
 H.A.Ac= High alarm (outside band) with automatic reset and acknowledge  
 L.A.Ac= Low alarm (inside band) with automatic reset and acknowledge

H.L. = High alarm (outside band) with manual reset  
 L.L. = Low alarm (inside band) with manual reset

**NOTE:** When alarm configuration has been changed, the alarm status will be cleared.

**A3AC** - Alarm 3 action - [r.F11]

This parameter is available only when OUT 3 is configured as alarm 3 output ("O3.Fn" [C.E03] = "ALr.3")

Range: dir = direct action (Relay energized or SSR=1 in alarm condition)  
 rEV = Reverse action (Relay energized or SSR=1 in non alarm condition)



### **A3SL** - Alarm 3 standby (mask) function - [r.F12]

This parameter is available only when OUT 3 is configured as alarm 3 output ("O3.Fn" [C.E03] = "ALr.3")

Range: OFF = Stand-by function disabled  
On = Stand-by function enabled

#### **NOTES:**

- 1) If the alarm is programmed as band or deviation alarm, this function masks the alarm condition after a set point change or at the instrument start-up until process variable reaches the alarm threshold plus or minus hysteresis. If the alarm is programmed as a process alarm or control output alarm, this function masks the alarm condition at instrument start-up until process variable reaches the alarm threshold plus or minus hysteresis.
- 2) The change from On to OFF has immediate effect, while the change from OFF to On has effect at the next start up or set point change

### **A4LP** - Alarm 4 type - [r.F13]

This parameter is available only when OUT 4 is configured as alarm 4 output ("O4.Fn" [C.E04] = "ALr.4")

Range: Proc = Alarm on process variable  
bAnd = Band alarm on process variable  
dEV = Deviation alarm on process variable  
ñAin = Alarm on Main control output value  
SECn = Alarm on Secondary control output value

**NOTE:** When alarm type has been changed the alarm threshold will be forced to its default value and alarm status will be cleared.

### **A4Ln** - Alarm 4 configuration - [r.F14]

This parameter is available only when OUT 4 is configured as alarm 4 output ("O4.Fn" [C.E04] = "ALr.4")

Range: H.A. = High alarm (outside band) with automatic reset  
L.A. = Low alarm (inside band) with automatic reset  
H.A.Ac= High alarm (outside band) with automatic reset and acknowledge  
L.A.Ac= Low alarm (inside band) with automatic reset and acknowledge

Gr.6

H.L. = High alarm (outside band) with manual reset  
L.L. = Low alarm (inside band) with manual reset

**NOTE:** When alarm configuration has been changed, the alarm status will be cleared.

Gr.6

**AL4AC** - Alarm 4 action - [r.F15]

This parameter is available only when OUT 4 is configured as alarm 4 output ("O4.Fn" [C.E04] = "ALr.4")

Range: dir = direct action (Relay energized or SSr=1 in alarm condition)

rEV = Reverse action (Relay energized or SSr=1 in non alarm condition)

**AL4SL** - Alarm 4 stand-by (mask) function - [r.F16]

This parameter is available only when OUT 4 is configured as alarm 4 output ("O4.Fn" [C.E04] = "ALr.4")

Range: OFF = Stand-by function disabled

On = Stand-by function enabled

**NOTES:**

- 1) If the alarm is programmed as band or deviation alarm, this function masks the alarm condition after a set point change or at the instrument start-up until process variable reaches the alarm threshold plus or minus hysteresis. If the alarm is programmed as a process alarm or control output alarm, this function masks the alarm condition at instrument start-up until process variable reaches the alarm threshold plus or minus hysteresis.
- 2) The change from On to OFF has immediate effect, while the change from OFF to On has effect at the next start up or set point change

**FdLn** - OFD (Output Failure Detection) alarm configuration - [r.F17]

This parameter is available only when OFD option is configured ("Fd.Fn" [C.I11] equal to "nC.On" or "nC.OF" or "SC.On" or "SC.OF").

Range: A. = Alarm with automatic reset  
A.Ac = Alarm with automatic reset and acknowledge  
L. = Alarm with manual reset

**NOTE:** When alarm configuration has been changed, the alarm status will be cleared.

**FdAc** - OFD (Output Failure Detection) alarm action - [r.F18]

This parameter is available only when one output is configured as OFD alarm annunciator ("Fd.Fn" [C.I11] equal to "nC.On" or "nC.OF" or "SC.On" or "SC.OF" and "Fd.Ou" [C.I13] is different from "nonE").

Range: dir = direct action (Relay energized or SSR=1 in alarm condition)  
rEV = Reverse action (Relay energized or SSR=1 in non alarm condition)

**NOTE:** When OFD output is in OR condition with an alarm or an event output, the "Fd.Ac" parameter can only be monitored but not modified and it assumes the same action defined (by "Alarm Action" or "Event Logic Level") for the alarm or the event.

**dFLE** - Group 6 default data loading - [r.F19]

Range: OFF = No loading data  
ON = Loading data

Gr.6

Run time group 7 [r.Gxx]  
SERIAL LINK PARAMETER

Gr. 7  
-----  
SrLn

Gr.7

**SLPr** - Serial interface protocol - [r.G01]

Range: OFF = No serial interface  
ñbUS = Modbus  
jbUS = Jbus

**NOTE:** When serial interface circuit is not mounted, the middle display will show "no.Pr"

**SLAd** - Serial link device address - [r.G02]

This parameter is available only when "S.L.Pr" [r.G01] is different from "OFF".  
Range: from 1 to 255

**SLbd** - Serial link baud rate - [r.G03]

This parameter is available only when "S.L.Pr" [r.G01] is different from "OFF".

Range: from 600 to 19200 baud (19200 baud is shown, on display, as 19.20)

**SLbF** - Serial link byte format - [r.G04]

This parameter is available only when "S.L.Pr" [r.G01] is different from "OFF".

Range: 8 = 8 bits without parity  
8E = 8 bits + even parity  
8O = 8 bits + odd parity

**dFLl** - Group 7 default data loading - [r.G05]

Range: OFF = No loading data  
ON = Loading data

Run time group 8 [r.Hxx]  
FEEDBACK POTENTIOMETER ADJUSTMENT

Gr. 8  
-----  
F.F.A.L

**NOTE:** The run time group 8 will be displayed only if the instrument is in MANUAL mode.

**F.F.A.L** - Feedback potentiometer adjustment enabling - [r.H01]

This parameter is available only when close loop servomotor output or open loop servomotor output with valve position indication is configured.

Range: OFF = this selection disables the feedback potentiometer calibration and the instrument will come back to the first display of the run time group 8.  
On = this selection starts the feedback potentiometer calibration.

**NOTE:** No time out will be applied during feedback potentiometer calibration procedure.

**P.O.S.L** - Servomotor low limit positioning - [r.H02]

This parameter is available only when feedback potentiometer calibration enabling [r.H01] is equal to On.

Range: 0.0% to 100.0%

The middle display will show the valve position as a percentage of the full input span.

By ▲ and ▼ push-button it is possible to modify the valve position.

When the desired initial position has been reached, push the FUNC push-button.

**F.F.L.C** - Feedback low limit calibration - [r.H03]

This parameter is available only when feedback potentiometer calibration enabling [r.H01] is equal to On.

Range: OFF = To skip calibration and hold the previous value select OFF and then push FUNC

On = To memorize the current position as feedback low limit calibration select "On" and then push FUNC

Gr.8

**POSH** - Servomotor high limit positioning - [r.H04]

This parameter is available only when feedback potentiometer calibration enabling [r.H01] is equal to On.

Range: 0.0% to 100.0%.

The middle display will show the valve position as a percentage of the full input span.

By ▲ and ▼ push-button it is possible to modify the valve position.

When the desired final position has been reached, push the FUNC push-button.

**FBHL** - Feedback high limit calibration - [r.H05]

This parameter is available only when feedback potentiometer calibration enabling [r.H01] is equal to ON.

Range: OFF = To skip calibration and hold the previous value  
select OFF and then push FUNC

On = To memorize the current position as feedback  
high limit calibration select "On" and then push  
FUNC

This procedure is now completed and the calibration values are automatically checked.

If the calibrated feedback span is greater than 20 % of the potentiometer input span, the instrument memorizes the new values and comes back to the first display of the run time group 8.

Otherwise the old calibration values will be retained and the display will show:

```
Gr. 8
Err
FCAL
```

It will be necessary to repeat the feedback potentiometer calibration procedure.

**dFLE** - Group 8 default data loading - [r.H6]

Range: OFF = No loading data  
On = loading data



**Run time group 9 [R.lxx]**  
 OPTIONAL OUTPUT SETTING

Gr. 9  
 ---  
 dOUT

**R.I01 - OUT 10 setting**

This parameter is available when optional output circuitry is fitted.

Upper display: Gr.9

Lower display: Ou.10

Range: OFF = Relay deenergized

On = Relay energized

For OUT 11 up to OUT 19, the instrument will show on the lower display the related output and it is possible to perform the same setting as above described.

**R.I02 - All relays deenergization**

This parameter is available when optional output circuitry is fitted.

Upper display: Gr.9

Lower display: dEEn

Range: OFF = No action

On = All relays will be deenergized



Run time group "dF" [r.lxx]  
DEFAULT RUN TIME PARAMETER LOADING.

Gr.dF  
-----  
dFLt

Gr.Hd

**dFLt** - Default run time parameter loading - [r.I01]

Default run time parameter loading of all run time parameters  
(all groups exception made for group 8).

Range: OFF = No loading data

On = the run time parameters of all groups (exception  
made for group 8) will be forced to their default  
values.

Run time group "Hd" [r.Lxx]  
HIDDEN PARAMETERS - SMART LIMITS

Gr.Hd  
-----  
H idn

**NOTE:** This group is accessible from every group by keeping  
depress the "MENU" key for 8 secs.

**Pb.Lo** - Minimum value of proportional band  
calculated by SMART algorithm - [r.L01]

This parameter is available only when smart function is  
configured ("Sn.Fn" [C.G01] = "Enb")  
Range: From 0.5% to "Pb.Hi" [r.L02].

**NOTE:** The resolution on "Pb.Lo" value will be equal to 0.1% up  
to 10.0% and 1% up to 999.0%.



**Pb.Hi** - Maximum value of proportional band calculated by SMART algorithm - [r.L02]

This parameter is available only when smart function is configured ("Sñ.Fn" [C.G01] = "Enb")  
Range: from "Pb.Lo" [r.L01] to 999.0%  
**NOTE:** The resolution on "Pb.Hi" value will be equal to 0.1% up to 10.0% and 1% up to 999.0

**ti.Lo** - Minimum value of integral time calculated by SMART algorithm - [r.L03]

This parameter is available only when smart function is configured ("Sñ.Fn" [C.G01] = "Enb")  
Range: from 00.01 mm.ss to "ti.Hi" [r.L04].

**ti.Hi** - Maximum value of integral time calculated by SMART algorithm - [r.L04]

This parameter is available only when smart function is configured ("Sñ.Fn" [C.G01] = "Enb")  
Range: from "ti.Lo" [r.L03] to 20.00 mm.ss

**r.Gn** - Relative gain of the secondary output calculated by SMART algorithm - [r.L05]

This parameter is available only when smart function is configured ("Sñ.Fn" [C.G01] = "Enb") and a secondary control output (without split range) is configured.

Range: OFF = Smart algorithm does not calculate "r.Gn" [r.d06] value.  
On = Smart algorithm calculates "r.Gn" [r.d06] value.

Gr.Hd



**DFLL** - Hidden group default data loading - [r.L06]

Range: OFF = No loading data  
On = loading data



## ERROR MESSAGES

### OVERRANGE, UNDERRANGE AND SENSOR LEADS BREAK DETECTION

#### ON THE MAIN INPUT

The device is capable to detect a fault condition on the main input (OVERRANGE or UNDERRANGE or SENSOR LEADS BREAK).

When the process variable exceeds the full scale value programmed by "ñ.In.t" [C.d02], an OVERRANGE condition will be shown on the upper display as show in the following figure:



When the process variable is lower than the initial scale value programmed by "ñ.In.t" [C.d02], an UNDERRANGE condition will be shown on the upper display as show in the following figure:



In presence of an main input out-of-range condition, the control outputs operate as follows:

a) When "SF.Cn" [C.G07] is set to "Std.":

a.1) An OVERRANGE is detected and

- the device is set for one control output only, the output will be forced to 0 % (if reverse action is programmed) or to 100% (if direct action is programmed).
- the device has two control outputs, the "Main" output is forced to 0 % and "Secondary" output is forced to 100%.

a.2) An UNDERRANGE is detected and

- the device is set for one output only, the output is forced to 100 % (if reverse action is programmed) or to 0 % (if direct action is programmed).
- the device has two control outputs, the "Main" output is forced to 100 % and "Secondary" output is forced to 0 %

b) With "SF.Cn" [C.G07] set to "Ov.Un", when an overrange or an underrange condition is detected, the power output is forced to the safety value "SF.UL" [C.G08].

c) When "SF.Cn" [C.G07] is set to "OvEr"

- c.1) if an overrange condition is detected, the power output is forced to the safety value "SF.UL" [C.G08]
- c.2) if an underrange condition is detected the instrument will operate as described at point a.2).

d) When "SF.Cn" [C.G07] is set to "Undr"

- d.1) if an underrange condition is detected, the power output is forced to the safety value "SF.UL" [C.G08]
- d.2) if an overrange condition is detected the instrument will operate as described at point a.1).

**NOTE: IN ALL CASES ABOVE DESCRIBED THE OUTPUTS WILL BE FURTHER INFLUENCED BY "OUTPUT CONDITIONING"**

When servomotor open loop is configured, the "Condition for output safety value" ("SF.Cn [C.G07]) acts as described below:

- 1) When "SF.Cn" [C.G07] is set to "Cnd.A" and an overrange or an underrange condition is detected, the servomotor is driven to its high limit position (OUT 3 "▲" will be maintained closed).
- 2) With "SF.Cn" [C.G07] is set to "Cnd.b" and an overrange or an underrange condition is detected, the servomotor is driven to its low limit position (OUT 4 "▼" will be maintained closed).
- 3) When "SF.Cn" [C.G07] is set to "Cnd.C" the out-of-range condition acts on the control output as the complement of effect described at point a).

These instruments are capable to detect, on the main input, the sensor leads break condition.

When the sensor leads break condition is detected, the instrument shows "OPEn" on the upper display.

**Note:** On the linear input the leads break can be detected only for 4-20 mA, 1-5 V, 2-10 V, 0-60mV and 12-60 mV ranges.

In addition, on RTD input a special test is provided to signal "Shrt" when input resistance is less than 12  $\Omega$  (Short circuit sensor detection).

When a fault condition different from overrange or underrange is detected on the main input, the alarms, the power output and the analog retransmissions operate as in presence of an overrange condition.

### ON THE AUXILIARY INPUT

When the remote set point signal exceeds the full scale value programmed by "A.In.t" [C.d10], an OVERRANGE condition will be shown on the lower display as shown in the following figure:



When the remote set point signal is lower than the initial scale value programmed by "A.In.t" [C.d10], an UNDERRANGE condition will be shown on the lower display as shown in the following figure:



These instruments are capable to detect, on the auxiliary input, the sensor leads break condition.

When the sensor leads break condition is detected, the instrument shows "OPEn" on the lower display.

**NOTE:** the leads break condition can be detected only if the selected range has a zero elevation( 4/20 mA or 1/5 V or 2/10 V).

### NOTES:

- 1) The fault conditions on the auxiliary input will be displayed only if the relative indication has been selected (see "Display function" at page. 62).
- 2) When a fault condition different from overrange or underrange is detected on the auxiliary input, the alarms, the power output and the analog retransmissions operate as in presence of an underrange condition.

### ERROR MESSAGES

At the end of each configuration parameter group modification the instrument check the new parameters values.

At instrument start up in operative mode, all the parameters are checked.

If an error is detected, the instrument will show:

- on the upper display,
  - the parameter family
  - CnF.x for configuration parameters
  - GRP. x for run time parameters
  - CAL for calibration parameterswhere x is the number of the specific group where the error has been detected.

- on the middle display, the "Err" indication
- on the lower display,
  - for configuration or run time parameter, it will show the mnemonic code of the group with the wrong parameter setting.
  - for calibration parameter, it will show the mnemonic code of the wrong calibration parameter.

The device resets automatically after a time out of 6 s (20 s if serial link is enabled)

#### Configuration and run time parameter errors.

When one of this error is detected, following the procedures described for standard parameter modification reach the group with the wrong parameter setting and correct it (every keystroke restarts the time out. The time out is disabled when modify configuration parameters mode is enabled)

When the error is corrected push "MENU" until the device resets (if in run mode) or end the modify configuration parameters mode following the normal procedure.

Repeat the above described procedure if another error is shown.

#### Feedback potentiometer adjustment error

Gr. 8  
Err  
F.CAL

If this error is detected (span less than 20% of complete potentiometer travel) push any key to load default calibration parameters  
Then remake the calibration following the normal procedure (see Gr.8 [r.Hxx]).

#### Calibration parameter errors

The instrument will show on the lower display one of the following indications:

ñ.l.tc = main termocouple input calibration error  
 ñ.l.CJ = could junction compensation error  
 ñ.l.rt = main RTD input calibration error  
 ñ.l.ñA = main mA input calibration error  
 ñ.l.5 = main 5V input calibration error  
 ñ.l.10 = main 10 V input calibration error  
 A.l.ñA = auxiliary mA input calibration error  
 A.l.5 = auxiliary 5V input calibration error  
 A.l.10 = auxiliary 10 V input calibration error  
 In.Ct = current transformer input calibration error  
 FEEd = electrical feedback input calibration error  
 05.ñA = output 5 mA calibration error  
 06.ñA = output 6 mA calibration error

When one of these errors is detected, contact your supplier.



### Other errors

The instrument is also capable to detect the following errors:

- E.100 Error during data saving in FRAM
- E.110 Error in FRAM handling
- E.500 Error during auto-zero measurement
- E.501 Error during zero integrator measurement
- E.502 Error during reference junction measurement. NOTE:  
this error may be generated by an ambient temperature  
higher than 70 °C (158 °F) or lower than -20 °C (-4 °F).

When one of these errors is detected, contact your supplier.

Two errors, related with the preliminary hardware setting, are detectable:

- 3. wrong position of the V301 dip switch.
- 8. wrong position of the V101 dip switch.

When one of these error is detected, the display blanks and the error code is shown on most significant digit of the upper display.

Remake V101 or V301 setting.

## GENERAL INFORMATIONS

### GENERAL SPECIFICATIONS

**Case:** Polycarbonate black color; self-extinguishing degree: V-0 according to UL 94.

**Front protection:** designed and tested for IP 65 (\*) and NEMA 4X (\*) for indoor locations (when panel gasket is installed).

(\*) Test were performed in accordance with IEC 529, CEI 70-1 and NEMA 250-1991 STD.

**Installation:** panel mounting.

**Rear terminal block:** 32 screw terminals ( screw M3, for cables from  $\phi$  0.25 to  $\phi$  2.5 mm<sup>2</sup> or from AWG 22 to AWG 14 ) with connections diagram and safety rear cover.

**Dimensions:** according to DIN 43700

- 48 x 96 mm, depth 128 mm for PKC model.

- 96 x 96 mm, depth 128 mm for MKC model.

**Weight:** 500 g for PKC model.

600 g for MKC model.

**Power supply:**

- 100 V to 240 V AC 50/60 Hz (-15% to + 10% of the nominal value).

- 24 V AC/DC ( $\pm$  10 % of the nominal value).

**Power consumption:**

- 15 VA max. for PKC model

- 16 VA max for MKC model

**Isolation voltage:** 2600 V rms according to IEC 1010-1.

**Display updating time:** 500 ms.

**Sampling time:** 125 ms for linear inputs  
250 ms for TC and RTD inputs.

**Resolution:** 30000 counts.

**Accuracy:**  $\pm$  0,2% f.s.v..  $\pm$  1 digit @ 25 °C ambient temperature.

**NOTE:** for TC type B the accuracy is guaranteed for temperature higher than 500 °C (950 °F).

**Common mode rejection:** 120 dB @ 50/60 Hz.

**Normal mode rejection:** 60 dB @ 50/60 Hz.

**Electromagnetic compatibility and safety requirements:**

This instrument is marked CE.

Therefore, it is conforming to council directives 89/336/EEC (reference harmonized standard EN 50081-1 and EN 50082-2) and to council directives 73/23/EEC and 93/68/EEC (reference harmonized standard EN 61010-1).

**Installation category:** II



**Temperature drift:** (CJ excluded)  
 < 200 ppm/°C of span for mV and TC ranges 3, 4, 7, 18, 19, 22.  
 < 300 ppm/°C of span for mA/V  
 < 250 ppm/°C of span for TC range 1, 2, 5, 6, 8, 9, 10, 14, 16, 17, 20, 21, 23, 24, 25, 29.  
 < 350 ppm/°C of span TC ranges 11, 12, 13, 26, 27, 28.  
 < 500 ppm/°C of span for RTD.  
**Operative temperature:** from 0 to 50 °C (+32 to 122 °F).  
**Storage temperature:** -20 to +70 °C (-4 to 158 °F)  
**Humidity:** from 20 % to 85% RH, non condensing.

**INPUTS**

**A) THERMOCOUPLE**

**Type:** J, K, T, E, N, S, R, B, L, U, G, D, C, Ni/Ni 18% Mo. °C/°F selectable.

**External resistance:** 100 Ω max, maximum error 0,1% of span.

**Cold junction:** automatic compensation from 0 to 50 °C.

**Cold junction accuracy :** 0.1 °C/°C

**Input impedance:** > 1 MΩ

**Calibration :** according to IEC 584-1 and DIN 43710 - 1977.

T/C type	Ranges		
L	1	-100 / 900 °C	DIN 43710-1977
J	2	-100 / 1000 °C	IEC 584-1
K	3	-100 / 1370 °C	IEC 584-1
T	4	-200 / 400 °C	IEC 584-1
U	5	-200 / 600 °C	DIN 43710-1977
E	6	-100 / 800 °C	IEC 584-1
N	7	-100 / 1400 °C	IEC 584-1
S	8	- 50 / 1760 °C	IEC 584-1
R	9	- 50 / 1760 °C	IEC 584-1
B	10	0 / 1820 °C	IEC 584-1
G	11	0 / 2300 °C	
D	12	0 / 2300 °C	
C	13	0 / 2300 °C	
Ni	14	0 / 1200 °C	
L	16	-150 / 1650 °F	DIN 43710-1977
J	17	-150 / 1830 °F	IEC 584-1
K	18	-150 / 2500 °F	IEC 584-1
T	19	-330 / 750 °F	IEC 584-1
U	20	-330 / 1110 °F	DIN 43710-1977
E	21	-150 / 1470 °F	IEC 584-1

T/C type	Ranges		
N	22	-150 / 2550 °F	IEC 584-1
S	23	- 60 / 3200 °F	IEC 584-1
R	24	- 60 / 3200 °F	IEC 584-1
B	25	32 / 3300 °F	IEC 584-1
G	26	0 / 4170 °F	
D	27	0 / 4170 °F	
C	28	0 / 4170 °F	
Ni	29	0 / 2190 °F	

**NOTE:** for TC type B the accuracy is guaranteed for temperature higher than 500 °C (950 °F).

**B) RTD (Resistance Temperature Detector)**

**Input:** for RTD Pt 100 Ω, 3-wire connection; °C/°F selectable.

**Measuring current:** 140 μA typical.

**Line resistance:** automatic compensation up to 20 Ω/wire with no measurable error.

STANDARD RANGES TABLE

Input type	Ranges		
RTD Pt 100 Ω	15	- 200 / + 850 °C	
	30	- 330 / + 1560 °F	

**C) LINEAR INPUTS**

**Read-out:** keyboard programmable between -1999 and +9999.

**Decimal point:** programmable in any position

STANDARD RANGES TABLE

Input type	impedance	
37	0 - 60 mV	> 1 MΩ
38	12 - 60 mV	
31	0 - 20 mA	< 5 Ω
32	4 - 20 mA	
33	0 - 5 V	> 200 kΩ
34	1 - 5 V	
35	0 - 10 V	> 400 kΩ
36	2 - 10 V	

#### AUXILIARY INPUT

**Type:** NOT isolated linear input.

**Function:** Programmable as remote set point input or bias on the local set point.

**Read-out:** keyboard programmable between -1999 and +9999.

**Temperature drift:** < 300 ppm.

**Sampling time:** 500 ms.

#### STANDARD RANGES TABLE

Input type	impedance	Accuracy
0 - 20 mA	< 5 $\Omega$	0.2 % $\pm$ 1 digit @ 25°C
4 - 20 mA		
0 - 5 V	> 200 k $\Omega$	
1 - 5 V		
0 - 10 V		
2 - 10 V	> 400 k $\Omega$	

#### LOGIC INPUTS

The instrument may be supplied with 3 logic inputs each one of them can be programmed as:

- Set point selection (SP-SP2)
- Set point selection (SP3-SP4)
- Local/remote set point selection
- Auto/manual selection

- Output limiter activation
- Data Hold of the measured value
- Manual reset of the alarms (acknowledge)
- Reverse/direct control action

**Input type:** Contact closure (voltage free).

**Active logic level:** Close or open programmable.

#### CURRENT TRANSFORMER INPUT FOR OUT FAILURE DETECTION

The instruments equipped with this feature are capable, by means of a CT, to detect and signal a possible failure of the line driven by a control output programmed as a time proportioning output (see "OUT failure detection").

**Input range:** 50 mA AC.

**Scaling:** programmable from 10 A to 100 A (with 1 A step).

**Resolution:**

- for full scale up to 25 A: 0.1 A.
- for full scale from 26 A to 100 A: 1 A

**Minimum duration of the period (ON or OFF) to perform the measurement:** 120 ms.

### SET POINTS

This instrument allows to use up to 4 set points: SP, SP2, SP3 and SP4.

The set point selection is possible only by logic input.

#### Set point transfer:

The transfer between one set point to another (or between two different set point values) may be realized by a step transfer or by a ramp with two different programmable rates of change (ramp up and ramp down).

**Slope value:** 1 - 200 eng. unit/min or step.

**Set points limiter:** rL [r.E12] and rH [r.E13] parameters, programmable.

### CONTROL ACTIONS

**Algorithm:** PID + SMART

#### Types:

- one control output (digital or analog output)
- one control output splitted on two outputs.
- two control outputs

**NOTE:** the outputs can be freely selected among analog, digital or servo outputs.

#### Digital output types:

Relay, SSR or TRIAC.

#### Digital output action type:

Proportional time

**Analog output types:** 20 mA.

#### Servomotor output:

Two relays with interlocked contact

#### Servomotor output type:

- Close loop
- Open loop with feedback for valve position indication only
- Open loop without feedback.

**Proportional Band:** programmable from 0.5% to 999.0% of the input span.

Setting a PB equal to 0 the control action becomes ON/OFF.

**Hysteresis (for ON/OFF control action):** programmable from 0.1% to 10.0 % of the input span.

**Integral time:** programmable from 1 second to 20 minutes or excluded.

**Derivative time:** programmable from 1 second to 10 minutes or excluded.

**Integral pre-load:** programmable

- for one control output, from 0 to 100% of the output range.
- for two control outputs (split range excluded), from -100 % to +100 % of the output range.

**Anti reset windup:** from 10 % to 200 % of the input span.  
**Main output cycle time:** from 1 second to 200 seconds.  
**Secondary output cycle time:** from 1 second to 200 seconds.  
**Relative secondary output gain:** keyboard programmable from 0.20 to 2.00 referred to the proportional band.  
**Overlap / dead band :** keyboard programmable from - 20 % (dead band) to + 50 % (overlap) of the proportional band.  
**Output limiters.**  
For the main and/or secondary control outputs it is possible to set:  
- output high limits  
- output low limits  
- output max. rate of rise.  
**AUTO/MANUAL mode:** selectable by front push-button or logic input.

## OUTPUTS

### Control output updating time :

- 125 ms when a linear input is selected
- 250 ms when a TC or RTD input is selected.

**Action:** direct/reverse programmable

### Output level limiter:

- high and low limits for main control output
- high and low limits for secondary control output.

### Out 1 and 2

**Function:** singularly programmable as

- Control output
- Alarm output
- Event output.

**Type:** Relay, SSR or TRIAC.

### Out 1 and 2 - Relay

**Relay type:** SPDT

**Contact rating:** 3 A @ 250 V on resistive load.

#### Out 1 and 2 - SSR

**Type:** not isolated voltage output

- Logic level 1:
  - 14V @ 20 mA max.
  - 24 V @ 1 mA.
- Logic level 0:
  - < 0.5 V D.C.

#### Out 1 and 2 - TRIAC

**Switching mode:** isolated zero crossing type.

**Rated current:** from 50 mA to 1 A.

**Rated voltage:** from 24 V<sub>RMS</sub> to 240 V<sub>RMS</sub> -10% +15% (50-60 Hz).

**Load type:** resistive load only

**I<sup>2</sup>t for external fuse:** 128

#### Out 3 and 4

**Function:** singularly programmable as:

- Control output
- Alarm output
- Event output.
- Servomotor drive (Out 3 ▲, out 4 ▼)

**Type:** Relay .

**Relay type:** SPST

**Contact rating:** 3 A @ 250 V on resistive load.

**Notes:**

- 1) The commons of the out 3 and 4 are connected together with the same rear terminal.
- 2) When OUT 3 and 4 are used as independent relay outputs the addition of the two currents must not exceed 3 A.

#### Servomotor output

**Type:** Two relays with interlocked contact (Out 3 and 4).

**Servomotor output type:**

- Close loop
- Open loop with feedback for valve position indication only
- Open loop without feedback.

**Feedback potentiometer input:** from 100 Ω to 10 kΩ.

**Servomotor travel time:** From 12 s to 3 minutes.

**Servomotor dead band:** From 1 % to 50 % of the feedback span or of the valve travel time.

#### Analog outputs

##### Out 5 and 6

**Function:** Programmable as

- Control output
- Analog retransmission of the measured value

- Analog retransmission of the operative set point.

**Output type:** Isolated output programmable as

- 0-20 mA
- 4-20 mA.

**Scaling:** programmable from -1999 to 9999.

**Maximum load:** 600  $\Omega$ .

**Accuracy:**

- 0.1 % when it is used as control output
- 0.05 % when it is used as analog retransmission. **Note:** a too little range scaling can deteriorate the output accuracy.

**Filter:** It is possible to apply a first order digital filter on the retransmitted value.

The time constant of the filter may be programmed within 0 and 8 s.

#### **Additional 5 + 5 outputs (OUT10 to 19)**

**Function:** singularly programmable as Event output.

**Type:** Relay .

**Relay type:** SPST

**Contact rating:** 0.5 A @ 250 V on resistive load.

**Note:** The commons of the out 10 to 14 connected together with the terminal 66 while the commons of the output 15 to 19 are connected with terminal 55.

#### **ALARMS**

**Alarm action:** direct or reverse function programmable.

**Alarm functions:** each alarm can be configured as process alarm, band alarm, deviation alarm, alarm on main or secondary control output value.

**Alarm reset:** automatic or manual reset programmable on each alarm.

**Alarm masking:** each alarm can be configured as masked alarm or standard alarm.

This function allows you to delete false indication at instrument start up and after a set point change.

**Process alarm:**

**Operative mode:** Minimum or maximum programmable.

**Threshold:** programmable in engineering unit within the input range.

**Hysteresis:** programmable in engineering units from 1 to 200 digits.

#### **Band alarm**

**Operative mode:** Inside or outside programmable.

**Threshold:** two thresholds programmable:

- Low - from 0 to -1000 digits.
- High - from 0 to +1000 digits.

**Hysteresis:** programmable in engineering units from 1 to 200 digits.

#### **Deviation alarm**

**Operative mode:** High or low programmable.

**Threshold:** programmable from - 1000 to +1000 digits.

**Hysteresis:** programmable in engineering units from 1 to 200 digits.

#### **Alarm on the main output value**

It is possible to obtain an alarm condition when the main control output is lower or higher than a programmed value.

**Operative mode:** Minimum or maximum programmable.

**Threshold:** programmable from 0.1 to 100.0 % of the output.

**Hysteresis:** programmable from 0.1 to 20.0 %.

#### **Alarm on the secondary output value**

It is possible to obtain an alarm condition when the secondary control output is lower or higher than a programmed value.

**Operative mode:** Minimum or maximum programmable.

**Threshold:** programmable from 0.1 to 100.0 % of the output.

**Hysteresis:** programmable from 0.1 to 20.0 %.

#### **EVENTS**

All digital outputs are programmable as events.

In this case they are used as input error annunciator or as instrument status indicator.

Event type:

- Error condition on the main input (overrange, underrange, open or short circuit).
- Error condition on the auxiliary input.
- Error condition on both inputs.
- Auto/Man mode annunciator
- Local/remote set point annunciator.

#### **AUXILIARY POWER SUPPLY**

**Type:** 24 V DC  $\pm$  20% not isolated.

**Max. current:** 25 mA.



### SERIAL INTERFACE

**Types:** RS 485 isolated.

**Protocol type:** MODBUS, JBUS.

**Baud rate:** programmable from 600 to 19200 BAUD.

**Byte format:** 8 bit.

**Parity:** even, odd or none programmable.

**Stop bit:** one.

**Address:** from 1 to 255.

**Output voltage levels:** according to EIA standard.

**NOTE:** The EIA standard establishes that by RS-485 interface it is possible to connect up to 30 devices with one remote master unit.

The serial interface of these instruments is based on "High input impedance" transceivers; this solution allows you to connect up to 127 devices (based on the same transceiver type) with one remote master unit.

### MAINTENANCE

1) REMOVE POWER FROM THE POWER SUPPLY TERMINALS AND FROM RELAY OUTPUT TERMINALS

2) Remove the instrument from case.

3) Using a vacuum cleaner or a compressed air jet (max. 3 kg/cm<sup>2</sup>) remove all deposit of dust and dirt which may be present on the louvres and on the internal circuits trying to be careful for not damage the electronic components.

4) To clean external plastic or rubber parts use only a cloth moistened with:

- Ethyl Alcohol (pure or denatured) [C<sub>2</sub>H<sub>5</sub>OH] or

- Isopropil Alcohol (pure or denatured) [(CH<sub>3</sub>)<sub>2</sub>CHOH] or

- Water (H<sub>2</sub>O)

5) Verify that there are no loose terminals.

6) Before re-inserting the instrument in its case, be sure that it is perfectly dry.

7) re-insert the instrument and turn it ON.

## DEFAULT PARAMETERS

### DEFAULT RUN TIME PARAMETERS

A complete and consistent set of run time parameters is memorized in the instrument. These data are the typical values loaded in the instrument prior to shipment from factory.

This instrument allows you to load the default value of a single run time parameter group or to load all the run time parameters (exception made for "Run time group 8" [r.Hxx]).

A) When it is desired to load the default parameter of a single group, proceed as follows:

A.1) By MENU pushbutton, select the desired run time parameter group.

A.2) By FUNC pushbutton, select the last parameter of the selected group.

The middle and lower display will show:

*OFF*  
*dFLt.*

A.3) By ▲ or ▼ pushbuttons, select the "On" indication on the central display.

A.4) Push the FUNC pushbutton.

The central display will show:

*End*

The default parameter loading procedure for the selected group is terminated.

B) When it is desired to load the default value of all the run time parameters (exception made for "Run time group 8" [r.Hxx]), proceed as follows:

B.1) By MENU pushbutton, select the "Run time group dF" [r.lxx].

B.2) Push the FUNC pushbutton.

The middle and lower display will show:

*OFF*  
*dFLt.*

B.3) By ▲ or ▼ pushbuttons, select the "On" indication on the central display.

B.4) Push the FUNC pushbutton.

The central display will show:

*LOAD*

and then it will show:

*End*

The default parameter loading procedure of all run time parameters is terminated.

A. 1

The following is a list of the default run time parameters loaded during the above procedure:

**Run time group 1 [r.Axx]**

PARAMETER	DEFAULT VALUE
SP	= Set point low limit ("rL" [r.E12])
SP2	= Set point low limit ("rL" [r.E12])
SP3	= Set point low limit ("rL" [r.E12])
SP4	= Set point low limit ("rL" [r.E12])

**Run time group 3 [r.Cxx]**

PARAMETER	DEFAULT VALUE
n.rSt	= OFF
AL1	= Initial range value (for process alarm) = 0 (for deviation alarm) = 0.0 (for control output alarm)
bA1.L	= 0
bA1.h	= 0
AL2	= Initial range value (for process alarm) = 0 (for deviation alarm) = 0.0 (for control output alarm)
bA2.L	= 0
bA2.h	= 0

AL3	= Initial range value (for process alarm) = 0 (for deviation alarm) = 0.0 (for control output alarm)
bA3.L	= 0
bA3.h	= 0
AL4	= Initial range value (for process alarm) = 0 (for deviation alarm) = 0.0 (for control output alarm)
bA4.L	= 0
bA4.h	= 0
A.L.Fd	= Initial scale value
A.H.Fd	= Final scale value
HSA1	= 1
HSA2	= 1
HSA3	= 1
HSA4	= 1

**Run time group 4 [r.dxx]**

PARAMETER	DEFAULT VALUE
Pb	= 4.0 %
HYS	= 0.5 %
ti	= 4.00 mm.ss
td	= 1.00 mm.ss
IP	= 50.0 (If only one control output is configured). 0.0 (If two control outputs, without split range, are configured).

A. 2

r.Gn = 1.00  
 OLAP = 0  
 Cn.Ac = rEV

**Run time group 5 [r.Exx]**

PARAMETER	DEFAULT VALUE
ArW	= 100%
Sñ.tt	= 1.00 m
Sñ.db	= 5%
ñ.OLL	= 0.0%
ñ.OLH	= 100.0%
ñ.rñP	= Inf
ñC.CY	= 15 s (If relay output) 2 s (If SSR output)
S.OLL	= 0.0%
S.OLH	= 100.0%
S.rñP	= Inf
SC.CY	= 15 s (If relay output) 2 s (If SSR output)
rL	= Initial range value
rH	= Final range value
Grd1	= Inf
Grd2	= Inf
tOL	= Inf
E.Añ	= On

E.Lr = On  
 E.rd = On

**Run time group 6 [r.Fxx]**

PARAMETER	DEFAULT VALUE
A1.tP	= Proc
A1.Cn	= H.A.
A1.Ac	= rEV
A1.St	= OFF
A2.tP	= Proc
A2.Cn	= H.A.
A2.Ac	= rEV
A2.St	= OFF
A3.tP	= Proc
A3.Cn	= H.A.
A3.Ac	= rEV
A3.St	= OFF
A4.tP	= Proc
A4.Cn	= H.A.
A4.Ac	= rEV
A4.St	= OFF
Fd.Cn	= A.
Fd.Ac	= rEV

**Run time group 7 [r.Gxx]**

PARAMETER	DEFAULT VALUE
S.L.Pr	= n̄bUS
S.L.Ad	= 1
S.L.bd	= 19.20
S.L.bF	= 8

**Run time group 8 [r.Hxx]**  
 The default calibration data are the complete potentiometer travel.  
**AFTER THE DEFAULT DATA LOADING OF THIS GROUP, IT IS NECESSARY TO PERFORM THE PROPER CALIBRATION**

**Run time group Hd [r.Lxx]**

PARAMETER	DEFAULT VALUE
Pb.Lo	= 1.0%
Pb.Hi	= 300.0%
ti.Lo	= 00.20 mm.ss
ti.Hi	= 20.00 mm.ss
rG.CL	= OFF

**DEFAULT CONFIGURATION PARAMETERS**

A complete and consistent set of configuration parameters is memorized in the instrument. These data are the typical values loaded in the instrument prior to shipment from factory. When it is desired to load the default value of all the configuration parameters, proceed as follows:

If the instrument starts in configuration mode, push the MENU pushbutton.  
 If the instrument starts in run time mode, by keeping depressed the MENU push-button for more than 5 seconds the instrument will show:

```
CONF
nont.
ADD
```

**NOTE:** If no push-button is depressed for more than 10 s (or 30 s according to "CnF.6" "t.out" [time out selection" C.110] parameter setting), the instrument returns automatically to the normal display mode.

By ▲ or ▼ push-button select "n̄odF."

**NOTES:**

- 1) When modify mode is started, the instrument stops the control and:
  - sets control outputs to OFF;
  - turned OFF the bargraph displays (MKC only);
  - sets analog retransmissions to the retransmitted initial scale value;
  - sets alarms in no alarm condition;
  - sets events to OFF;
  - disables the serial link;
  - the time out will be removed.
- 2) When the modify mode is disabled by V101 (SW3), the ▲ or ▼ push-button pressure has no effect.

Push MENU pushbutton again and select the "Default configuration group" [C.Cxx].  
By ▲ or ▼ push-button select the desired configuration parameter set ("tb.1" or "tb.2")  
Push MENU pushbutton again  
The central display will show:

*LOAD*

and then the display will show:

*CONF. 1*

*INPt.*

The default parameter loading procedure of all configuration parameters is terminated.

The following is a list of the default configuration parameters loaded during the above procedure:

**TABLE 1**

Configuration group 1 [C.dxx]		
PARAM.	VALUE	NOTES
Ln.Fr	50	Hz
ñ.In.t	3	TC K with °C
ñ.In.d	—.	(No decimal figure)
ñ.In.S	dIS	Disabled
ñ.In.L	- 100	°C
ñ.In.H	1370	°C
OFSt	0	°C
dS.FL	0	(No filter)
A.In.F	RSP	Remote set point

A.In.t	4-20	mA
A.In.L	0	°C
A.In.H	1000	°C
A.I.FL	0	(No filter)
A.I.Añ	norñ	
A.I.Sc	nonE	
L.r.O.ñ	n.ALG	

**Configuration group 2 [C.Exx]**

PARAM.	VALUE	NOTES
O1.Fn	ñAin	If servo motor drive is not mounted
	ALr.1	If servo motor drive or linear output is mounted
O2.Fn	ALr.2	
O3.Fn	nonE	If option is not mounted
	ñC.Sñ	If servo control motor drive is mounted
	ALr.3	If option is mounted
O4.Fn	nonE	If option is not mounted
	ALr.4	If option is mounted
Sñ.tP	CLSd	If feedback circuitry is mounted
	OPEn	If feedback circuitry is not mounted
FEEd	no.Fb	
O5.Fn	nonE	If option is not mounted
	ñAin	If option is mounted

O5.rn	4-20	4-20 mA
O5.Lr	0	°C
O5.Hr	1000	°C
O5.FL	0	No filter
O6.Fn	nonE	If option is not mounted
	PV.rt	If option is mounted
O6.rn	4-20	4-20 mA
O6.Lr	0	°C
O6.Hr	1000	°C
O6.FL	0	(No filter)

**Configuration group 3 [C.Fxx]**

PARAM.	VALUE	NOTES
SPLt.	dIS	
ñC.Gn	2.00	
ñC.bS	-50.0	
SC.Gn	2.00	
SC.bS	0.0	
ñC.Cn	norñ	
ñ.SCL	nO	
ñC.dP	—.	(No decimal figure)
ñC.E.L	0	
ñC.E.H	100	
ñC.A.C	bEFr	
SC.Cn	norñ	

S.SCL	nO	
SC.dP	—.	(No decimal figure)
SC.E.L	0	
SC.E.H	100	
SC.A.C	bEFr	

**Configuration group 4 [C.Gxx]**

PARAM.	VALUE	NOTES
Sñ.Fn	Enb	
Cn.tP	PId	
ñAn.F	Enb	
Añ.UL	buñ.	
ñ.A.t.t	buñ.	
St.Fn	Cnd.b	
SF.Cn	Std.	
SF.UL	0.0	

**Configuration group 5 [C.Hxx]**

PARAM.	VALUE	NOTES
d1.Fn	SP1.2	
d1.St	CLSd	
d2.Fn	SP3.4	
d2.St	CLSd	
d3.Fn	ñ.rSt	
d3.St	CLSd	

E1.Fn	ñ.In.E
E1.St	CLSd
E2.Fn	ñEA.E
E2.St	CLSd
E3.Fn	Au.ñA
E3.St	CLSd
E4.Fn	SP.L.r
E4.St	CLSd

**Configuration group 6 [C.Ixx]**

PARAM.	VALUE	NOTES
G.brG	DEv	
O.brG	P.Out	
brG.L	-100	°C
brG.H	1370	°C
brG.d	10	°C
SP.AL	n.ALG	
SP.dS	OP.SP	
Sr.bH	bAL	
SS.tr	-100	°C
t.out	tñ.10	
Fd.Fn	nonE	If option is not mounted or main control output is linear
	ñC.On	If option is mounted
Fd.HS	25	



Fd.Ou nonE

**TABLE 2**

<b>Configuration group 1 [C.dxx]</b>		
PARAM.	VALUE	NOTES
Ln.Fr	60	Hz
ñ.In.t	18	(TC K with °F)
ñ.In.d	—.	(No decimal figure)
ñ.In.S	dIS	Disabled
ñ.In.L	-150	°F
ñ.In.H	2500	°F
OFSt	0	°F
dS.FL	0	(No filter)
A.In.F	RSP	Remote set point
A.In.t	4-20	mA
A.In.L	32	°F
A.In.H	1832	°F
A.I.FL	0	(No filter)
A.I.Añ	norñ	
A.I.Sc	nonE	
L.r.O.ñ	n.ALG	

**Configuration group 2 [C.Exx]**

PARAM.	VALUE	NOTES
O1.Fn	ñAin	If servo motor drive is not mounted
	ALr.1	If servo motor drive or linear output are mounted
O2.Fn	ALr.2	
O3.Fn	nonE	If option is not mounted
	ñC.Sñ	If servo control motor drive is mounted
	ALr.3	If option is mounted
O4.Fn	nonE	If option is not mounted
	Alr.4	If option is mounted
Sñ.tP	CLSd	If feedback circuitry is mounted
	OPEn	If feedback circuitry is not mounted
FEEd	no.Fb	
O5.Fn	nonE	If option is not mounted
	ñAin	If option is mounted
O5.rn	4-20	4-20 mA
O5.Lr	32	°F
O5.Hr	1832	°F
O5.FL	0	No filter
O6.Fn	nonE	If option is not mounted
	PV.rt	If option is mounted
O6.rn	4-20	4-20 mA
O6.Lr	32	°F

O6.Hr 1832 °F  
 O6.FL 0 (No filter)

**Configuration group 3 [C.Fxx]**

PARAM.	VALUE	NOTES
SPLt.	dIS	
ñC.Gn	2.00	
ñC.bS	-50.0	
SC.Gn	2.00	
SC.bS	0.0	
ñC.Cn	norñ	
ñ.SCL	nO	
ñC.dP	—.	(No decimal figure)
ñC.E.L	0	
ñC.E.H	100	
C.A.C	bEFr	
SC.Cn	norñ	
S.SCL	nO	
SC.dP	—.	(No decimal figure)
SC.E.L	0	
SC.E.H	100	
SC.A.C	bEFr	

**Configuration group 4 [C.Gxx]**

PARAM.	VALUE	NOTES
Sñ.Fn	Enb	
Cn.tP	PId	
ñAn.F	Enb	
Añ.UL	buñ.	
ñ.A.t.t	buñ.	
St.Fn	Cnd.b	
SF.Cn	Std.	
SF.UL	0.0	

**Configuration group 5 [C.Hxx]**

PARAM.	VALUE	NOTES
d1.Fn	SP1.2	
d1.St	CLSd	
d2.Fn	SP3.4	
d2.St	CLSd	
d3.Fn	ñ.rSt	
d3.St	CLSd	
E1.Fn	ñ.In.E	
E1.St	CLSd	
E2.Fn	ñEA.E	
E2.St	CLSd	
E3.Fn	Au.ñA	
E3.St	CLSd	

E4.Fn SP.L.r  
E4.St CLSd

**Configuration group 6 [C.lxx]**

PARAM.	VALUE	NOTES
G.brG	DEv	
O.brG	P.Out	
brG.L	-150	°F
brG.H	2500	°F
brG.d	10	°F
SP.AL	n.ALG	
SP.dS	OP.SP	
Sr.bH	bAL	
SS.tr	-150	°F
t.out	tñ.10	
Fd.Fn	nonE	If option is not mounted or main control output is linear
	ñC.On	If option is mounted
Fd.HS	25	
Fd.Ou	nonE	



A. 11



Xkc-AA0.p65

11

5/29/02, 12:00 PM



## ALPHANUMERIC INDEX OF THE DISPLAY INDICATIONS

### RUN TIME PARAMETERS

<i>RCEr</i>	Run time group 5 - AUXILIARY CONTROL PARAMETER .....	page 80
<i>RHFd</i>	OUTPUT FAILURE DETECTION HIGH ALARM THRESHOLD .....	76
<i>RLFd</i>	OUTPUT FAILURE DETECTION LOW ALARM THRESHOLD .....	76
<i>RSEt</i>	Run time group 6 - ALARM SETTING .....	85
<i>RAAc</i>	ALARM 1 ACTION .....	86
<i>RAcn</i>	ALARM 1 CONFIGURATION .....	85
<i>RASt</i>	ALARM 1 STANDBY FUNCTION .....	85
<i>RAtP</i>	ALARM 1 TYPE .....	85
<i>RAAc</i>	ALARM 2 ACTION .....	87
<i>RAcn</i>	ALARM 2 CONFIGURATION .....	86
<i>RASt</i>	ALARM 2 STANDBY FUNCTION .....	87
<i>RAtP</i>	ALARM 2 TYPE .....	86
<i>RAAc</i>	ALARM 3 ACTION .....	88
<i>RAcn</i>	ALARM 3 CONFIGURATION .....	88
<i>RASt</i>	ALARM 3 STANDBY FUNCTION .....	89

<i>RAStP</i>	ALARM 3 TYPE .....	88
<i>RAAc</i>	ALARM 4 ACTION .....	90
<i>RAcn</i>	ALARM 4 CONFIGURATION .....	89
<i>RASt</i>	ALARM 4 STANDBY FUNCTION .....	90
<i>RAtP</i>	ALARM 4 TYPE .....	89
<i>RL1</i>	ALARM 1 THRESHOLD .....	73
<i>RL2</i>	ALARM 2 THRESHOLD .....	74
<i>RL3</i>	ALARM 3 THRESHOLD .....	75
<i>RL4</i>	ALARM 4 THRESHOLD .....	75
<i>RLrn</i>	Run time group 3 - ALARM THRESHOLD AND HYSTERESIS VALUE .....	73
<i>RAw</i>	ANTIRESET WINDUP .....	80
<i>hA1h</i>	HIGH THRESHOLD USED WHEN ALARM 1 IS A BAND ALARM .....	74
<i>hA1L</i>	LOW THRESHOLD USED WHEN ALARM 1 IS A BAND ALARM .....	73
<i>hA2h</i>	HIGH THRESHOLD USED WHEN ALARM 2 IS A BAND ALARM .....	74
<i>hA2L</i>	LOW THRESHOLD USED WHEN ALARM 2 IS A BAND ALARM .....	74
<i>hA3h</i>	HIGH THRESHOLD USED WHEN ALARM 3 IS A BAND ALARM .....	75
<i>hA3L</i>	LOW THRESHOLD USED WHEN ALARM 3 IS A BAND ALARM .....	75

B. 1

<i>bR4h</i>	HIGH THRESHOLD USED WHEN ALARM 4 IS A BAND ALARM .....	76	<i>Hidn</i>	Run time Menu hidden SMART LIMIT VALUE .....	95
<i>bR4L</i>	LOW THRESHOLD USED WHEN ALARM 4 IS A BAND ALARM .....	76	<i>HSP1</i>	ALARM 1 HYSTERESIS .....	77
<i>CnRc</i>	CONTROL ACTION .....	79	<i>HSP2</i>	ALARM 2 HYSTERESIS .....	77
<i>Cntr</i>	Run time group 4 - CONTROL PARAMETER .....	78	<i>HSP3</i>	ALARM 3 HYSTERESIS .....	77
<i>ERN</i>	EXTERNAL CONTROL OF AUTO/MAN MODE .....	84	<i>HSP4</i>	ALARM 4 HYSTERESIS .....	77
<i>ELr</i>	EXTERNAL CONTROL OF LOCAL/REMOTE SETPOINT SELECTION .....	84	<i>HYS</i>	HYSTERESIS .....	78
<i>ErD</i>	EXTERNAL CONTROL OF REVERSE/DIRECT OUTPUT ACTION SELECTION .....	84	<i>IP</i>	INTEGRAL PRE-LOAD .....	79
<i>EnCL</i>	FEEDBACK POTENTIOMETER ADJUSTMENT ENABLING .....	93	<i>nDLH</i>	MAIN CONTROL OUTPUT HIGH LIMIT .....	81
<i>FLRL</i>	Run time group 8 - FEEDBACK POTENTIOMETER CALIBRATION .....	93	<i>nDLL</i>	MAIN CONTROL OUTPUT LOW LIMIT .....	81
<i>FbHL</i>	FEEDBACK HIGH LIMIT CALIBRATION .....	94	<i>nRnP</i>	MAIN CONTROL OUTPUT MAX RATE OF RISE .....	81
<i>FbLL</i>	FEEDBACK LOW LIMIT CALIBRATION .....	93	<i>nRSt</i>	MANUAL RESET (ACKNOWLEDGE) OF THE ALARMS .....	73
<i>FdRc</i>	OFD ALARM ACTION .....	91	<i>nCCY</i>	MAIN OUTPUT CYCLE TIME .....	81
<i>FdLn</i>	OFD ALARM CONFIGURATION .....	91	<i>OLRP</i>	DEAD BAND/OVERLAP BETWEEN MAIN AND SECONDARY OUTPUT .....	79
<i>Grd1</i>	RATE OF CHANGE FOR POSITIVE SETPOINT VARIATION .....	83	<i>Pb</i>	PROPORTIONAL BAND .....	78
<i>Grd2</i>	RATE OF CHANGE FOR NEGATIVE SETPOINT VARIATION .....	83	<i>PbH,</i>	MAX VALUE OF PROPORTIONAL BAND CALCULATED BY THE SMART ALGORITHM .....	96
			<i>PbLo</i>	MIN VALUE OF PROPORTIONAL BAND CALCULATED BY THE SMART ALGORITHM .....	96
			<i>PSSH</i>	POSITIONING OF SERVO AT HIGH LIMIT .....	94
			<i>PSSL</i>	POSITIONING OF SERVO AT LOW LIMIT .....	93
			<i>rGn</i>	RELATIVE SECONDARY OUTPUT GAIN .....	79

<i>rGCL</i>	RELATIVE GAIN OF THE SECONDARY OUTPUT CALCULATION BY SMART ALGORITHM .....	96	<i>SPn</i>	Run time group 1 - SETPOINT VALUES .....	71
<i>rH</i>	SETPOINT HIGH LIMIT .....	83	<i>td</i>	DERIVATIVE TIME .....	79
<i>rL</i>	SETPOINT LOW LIMIT .....	82	<i>ti</i>	INTEGRAL TIME .....	78
<i>SLAd</i>	SERIAL LINK DEVICE ADDRESS .....	92	<i>tiH</i>	MAX VALUE OF INTEGRAL TIME VALUE CALCULATED BY THE SMART ALGORITHM .....	96
<i>SLbd</i>	SERIAL LINK BAUDE RATE .....	92	<i>tiL</i>	MIN VALUE OF INTEGRAL TIME VALUE CALCULATED BY THE SMART ALGORITHM .....	96
<i>SLbF</i>	SERIAL LINK BYTE FORMAT .....	92	<i>tDL</i>	TIMEOUT FOR SOFT START .....	83
<i>SLPr</i>	SERIAL INTERFACE PROTOCOL .....	92			
<i>SOLH</i>	SECONDARY CONTROL OUTPUT HIGH LIMIT .....	82			
<i>SOLL</i>	SECONDARY CONTROL OUTPUT LOW LIMIT .....	82			
<i>Sr nP</i>	SECONDARY CONTROL OUTPUT MAX RATE OF RISE .....	82			
<i>SCCY</i>	SECONDARY OUTPUT CYCLE TIME .....	82			
<i>Sndb</i>	SERVO MOTOR DEAD BAND .....	81			
<i>Sntt</i>	SERVO MOTOR TRAVEL TIME .....	80			
<i>Snr t</i>	Run time group 2 - SMART ENABLE/DISABLE .....	72			
<i>Snr t</i>	SMRT ENABLED OR DISABLED .....	72			
<i>SP</i>	MAIN SETPOINT .....	71			
<i>SP2</i>	SETPOINT 2 .....	71			
<i>SP3</i>	SETPOINT 3 .....	71			
<i>SP4</i>	SETPOINT 4 .....	71			
<i>SrLn</i>	Run time group 7 - SERIAL LINK PARAMETER .....	92			

**CONFIGURATION PARAMETERS**

<i>R iRn</i>	AUXILIARY INPUT ACTIVATION MODE .....	34	<i>d2Fn</i>	LOGIC INPUT 2 FUNCTION .....	52
<i>R iFL</i>	FILTER ON AUXILIARY INPUT VALUE .....	34	<i>d2St</i>	LOGIC INPUT 2 CONTACT STATUS .....	53
<i>R iSc</i>	AUXILIARY INPUT SAFETY CONDITION .....	35	<i>d3Fn</i>	LOGIC INPUT 3 FUNCTION .....	53
<i>R inF</i>	AUXILIARY INPUT FUNCTION .....	33	<i>d3St</i>	LOGIC INPUT 3 CONTACT STATUS .....	53
<i>R inH</i>	AUXILIARY INPUT READ-OUT INITIAL SCALE VALUE .....	34	<i>d5FL</i>	FILTER ON THE DISPLAYED VALUE .....	33
<i>R inL</i>	AUXILIARY INPUT READ-OUT FULL SCALE VALUE .....	34	<i>E iFn</i>	EVENT 1 FUNCTION .....	54
<i>R inT</i>	AUXILIARY INPUT TYPE .....	33	<i>E iSt</i>	EVENT 1 CONTACT STATUS .....	54
<i>REEn</i>	Configuration group 4 - AUXILIARY CONTROL OUTPUT CONFIGURATION .....	47	<i>E2Fn</i>	EVENT 2 FUNCTION .....	54
<i>RnWL</i>	OUTPUT VALUE FOR AUTO TO MANUAL TRANSFERT .....	48	<i>E2St</i>	EVENT 2 CONTACT STATUS .....	55
<i>brGd</i>	RESOLUTION OF THE DEVIATION BARGRAPH .....	58	<i>E3Fn</i>	EVENT 3 FUNCTION .....	55
<i>brGH</i>	BARGRAPH FULL SCALE VALUE .....	58	<i>E3St</i>	EVENT 3 CONTACT STATUS .....	56
<i>brGL</i>	BARGRAPH INITIAL SCALE VALUE .....	58	<i>E4Fn</i>	EVENT 4 FUNCTION .....	56
<i>EEEn</i>	Configuration group 3 CONTROL OUTPUT CONFIGURATION .....	41	<i>E4St</i>	EVENT 4 CONTACT STATUS .....	56
<i>EntP</i>	CONTROL ACTION TYPE .....	47	<i>FdFn</i>	OUTPUT FAILURE DETECTION .....	60
<i>d iFn</i>	LOGIC INPUT 1 FUNCTION .....	51	<i>FdHS</i>	PRIMARY CURRENT OF THE CURRENT TRANSFORMER .....	60
<i>d iSt</i>	LOGIC INPUT 1 CONTACT STATUS .....	52	<i>FdUv</i>	OUTPUT FAILURE DETECTION - OUTPUT ASSIGNEMENT .....	61
			<i>FEEd</i>	VALVE POSITION INDICATION .....	38
			<i>GbrG</i>	GREEN BARGRAPH FUNCTION .....	57
			<i>inSt</i>	Configuration group 5 - DIGITAL INPUT/OUTPUT CONFIGURATION .....	51
			<i>inPt</i>	Configuration group 1 - MAIN/AUXILIARY INPUT CONFIGURATION .....	30



<i>LrDn</i>	LOCAL/REMOTE SETPOINT OPERATING MODE .....	35	<i>O3Fn</i>	OUT 3 FUNCTION .....	37
<i>LnFr</i>	LINE FREQUENCY .....	30	<i>O4Fn</i>	OUT 4 FUNCTION .....	37
<i>nRtE</i>	MANUAL/AUTO TRANSFER TYPE .....	48	<i>O5FL</i>	OUT 5 FILTER ON THE RETRANSMITTED VALUE .....	39
<i>nInd</i>	DECIMAL POINT POSITION .....	31	<i>O5Fn</i>	OUT 5 FUNCTION .....	38
<i>nInH</i>	READOUT FULL SCALE VALUE .....	32	<i>O5Hr</i>	OUT 5 RETRANSMISSION FULL SCALE VALUE .....	38
<i>nInL</i>	READOUT INITIAL SCALE VALUE .....	32	<i>O5Lr</i>	OUT 5 RETRANSMISSION INITIAL SCALE VALUE .....	38
<i>nInS</i>	SQUARE ROOT EXTRACTION FOR MAIN INPUT .....	31	<i>O5rn</i>	OUT 5 RANGE .....	38
<i>nInE</i>	MAIN INPUT TYPE AND RANGE .....	30	<i>O6FL</i>	OUT 6 FILTER ON THE RETRANSMITTED VALUE .....	40
<i>nSCL</i>	MAIN CONTROL OUTPUT IN ENG. UNIT .....	44	<i>O6Fn</i>	OUT 6 FUNCTION .....	39
<i>nRnF</i>	MANUAL FUNCTION .....	48	<i>O6Hr</i>	OUT 6 RETRANSMISSION FULL SCALE VALUE .....	39
<i>nRC</i>	MAIN CONTROL OUTPUT AUXILIARY CONDITIONING .....	45	<i>O6Lr</i>	OUT 6 RETRANSMISSION INITIAL SCALE VALUE .....	39
<i>nCbS</i>	MAIN CONTROL OUTPUT BIAS .....	42	<i>O6rn</i>	OUT 6 RANGE .....	39
<i>nCCn</i>	MAIN CONTROL OUTPUT CONDITIONING .....	43	<i>OFSL</i>	MAIN INPUT OFFSET ADJUSTMENT .....	33
<i>nCdP</i>	MAIN CONTROL OUTPUT DECIMAL POINT POSITION .....	44	<i>Othr</i>	Configuration group 6 OTHER CONFIGURATION PARAMETER .....	57
<i>nCEH</i>	MAIN OUTPUT FULL SCALE VALUE .....	44	<i>OLL</i>	Configuration group 2 OUTPUT CONFIGURATION .....	36
<i>nCEL</i>	MAIN OUTPUT INITIAL SCALE VALUE .....	44			
<i>nCGn</i>	MAIN CONTROL OUTPUT GAIN .....	42			
<i>ObrG</i>	ORANGE BARGRAPH FUNCTION .....	57			
<i>O1Fn</i>	OUT 1 FUNCTION .....	36			
<i>O2Fn</i>	OUT 2 FUNCTION .....	36			

<i>SSCL</i>	SECONDARY CONTROL OUTPUT IN ENG. UNIT .....	46	<i>SSLH</i>	INPUT THRESHOLD TO ENABLE THE SOFT START .....	59
<i>SCRC</i>	SECONDARY CONTROL OUTPUT AUXILIARY CONDITIONING .....	46	<i>StFn</i>	DEVICE STATUS AT START UP .....	49
<i>SCbS</i>	SECONDARY CONTROL OUTPUT BIAS .....	42	<i>tout</i>	TIMEOUT SELECTION .....	60
<i>SCEn</i>	SECONDARY CONTROL OUTPUT CONDITIONING .....	45			
<i>SCdP</i>	SECONDARY CONTROL OUTPUT DECIMAL POINT POSITION .....	46			
<i>SCeH</i>	SECONDARY CONTROL OUTPUT FULL SCALE VALUE .....	46			
<i>SCeL</i>	SECONDARY CONTROL OUTPUT INITIAL SCALE VALUE .....	46			
<i>SCGn</i>	SECONDARY CONTROL OUTPUT GAIN .....	42			
<i>SFLn</i>	CONDITION FOR OUTPUT SAFETY VALUE .....	49			
<i>SFUL</i>	OUTPUT SAFETY VALUE .....	50			
<i>SFn</i>	SMART FUNCTION .....	47			
<i>SnTP</i>	SERVOMOTOR TYPE .....	37			
<i>SPRL</i>	OPERATIVE SETPOINT ALIGNEMENT AT START UP .....	58			
<i>SPdS</i>	SETPOINT DISPLAY TYPE .....	59			
<i>SPLt</i>	SPLIT RANGE .....	41			
<i>SrbH</i>	SERVO BEHAVIOR WHEN THE POWER OUTPUT IS LIMITED .....	59			

**MODEL:** MKC = 1/4 DIN  
PKC = 1/8 DIN

**CODING**

**INPUT:** 1 = Main + Aux-in + Logic Inputs  
5 = Main + OFD (or Feedback selectable)  
6 = Main + Aux-in + Logic Inputs +OFD (or Feedback selectable)  
9 = Main

**OUT1 and OUT2:** 11 = Two relay outputs  
44 = Two TRIAC outputs  
61 = One SSR + one relay output  
66 = Two SSR outputs

**OUT3 and OUT4:** 0 = Not provided  
1 = Two relay outputs  
2 = Two relay outputs interlockable by jumper (for servomotor output)

**OUT5 and OUT6:** 0 = Not provided  
5 = Two mA outputs  
7 = One mA output (Out 5)

**OPTIONS:** 0 = Not provided  
1 = Aux. PWS  
2 = RS485 + Aux. PWS  
3 = RS485  
6\* = RS485 + Aux. PWS + 4 Log. in + 5 Digital out.  
7\* = RS485 + Aux. PWS + 8 Log. in + 10 Digital out.

\* For MKC only

**POWER SUPPLY:** 3 = 100/240V AC  
5 = 24V AC/DC



B. 7





**Ero Electronic S.r.l.**  
Via E. Mattei, 21  
28100 Novara  
Italy  
Tel. +39 0321481111  
Fax +39 0321481112  
E-mail [eroelectronic@ero.eurotherm.co.uk](mailto:eroelectronic@ero.eurotherm.co.uk)  
[Http://www.eroelectronic.com](http://www.eroelectronic.com)