

Eurotherm®

2604 Advanced process controller/programmer

Override Control Supplement



What is Override Control

One of the advanced control functions provided by the 2604 series controller is Override (Select Output) control. Override control allows a secondary control loop to override the main control output in order to prevent an undesirable operating condition. The override function can be configured to operate in either minimum, maximum or select mode. Override control is available with analogue, time proportioning and ON/OFF control outputs, it is not available to be used with Valve Position outputs.

A typical example, shown below can be implemented in a heat treatment furnace with one thermocouple attached to the workpiece (main), and another situated close to the heating elements (override). Control of the furnace during the heating up period is regulated by the override (element) thermocouple which provides a safeguard against overheating. Control of the furnace will switch over to the workpiece (main) thermocouple at a defined point, usually when the temperature is near its target setpoint. The exact point of switchover is determined automatically by the controller, and will be dependent on the selected PID terms.

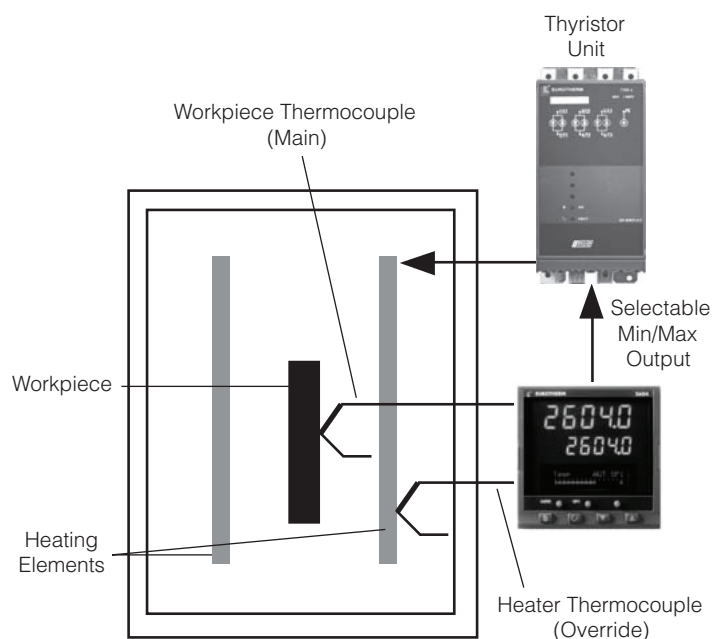

Heat treatment furnace with override control

- Reduces time to setpoint
- Selective output control
- “Soft” operating limits
- Thermal head control
- Delta T control

2604 Override Control Supplement

Thermal Head Control

Thermal Head Control is a simple technique often used in furnaces and autoclaves. By maintaining a constant temperature gradient between the heater and the workpiece, a constant heat transfer from the heater to the workpiece is maintained. This arrangement improves the efficiency of the furnace by minimizing the heat up time and the energy consumed. One possible arrangement is shown in the diagram below is to set the SP Trim value of the Override controller equal to desired thermal head. In this application

the setpoint programmer generates the setpoint for both loops, with the override setpoint being offset by the SP trim value. The main controller regulates the temperature of the workpiece and the controller maintains a maximum thermal head between the heater and the workpiece. A further enhancement of this application could allow the setpoint programmer to vary the thermal head setpoint from directly under program control.

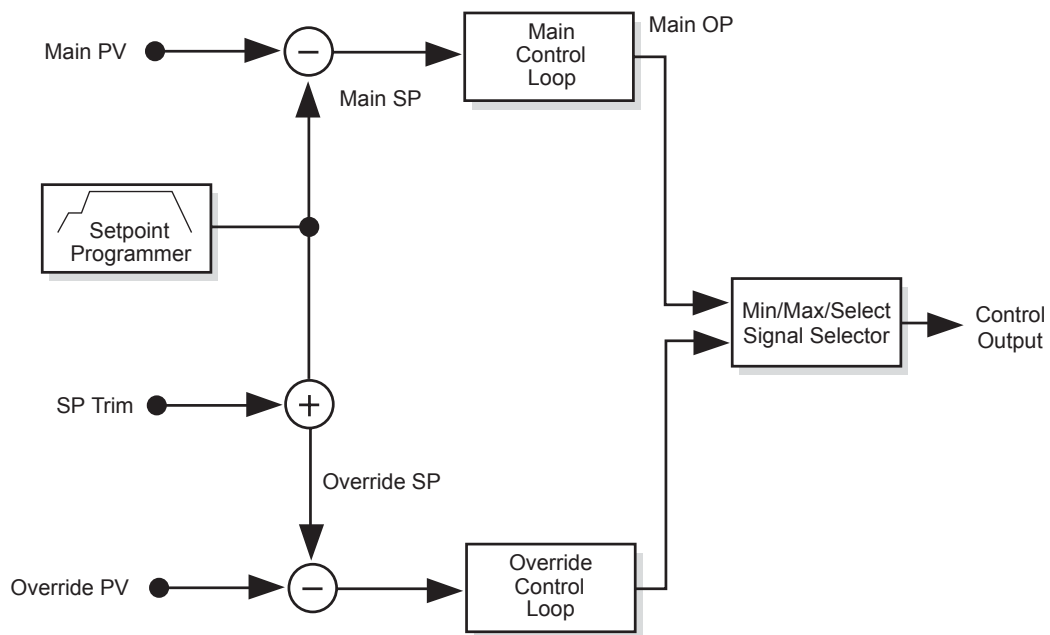

Thermal Head Control

Eurotherm
Faraday Close, Worthing,
West Sussex, BN13 3PL
United Kingdom
Phone: + 44 (0)1903 268500

www.eurotherm.com

Document No. HA026747 Issue 4

Watlow, Eurotherm, EurothermSuite, EFit, EPack, EPower, Eyon, Chessell, Mini8, nanodac, piccolo and versadac are trademarks and property of Watlow its subsidiaries and affiliated companies. All other trademarks are the property of their respective owners.

©Watlow Electric Manufacturing Company. All rights reserved.

Contact your local sales representative

