

4000R



EUROTHERM
CHESSELL

Model 4000R
I/O rack

Manual
Supplement



Declaration of Conformity

Manufacturer's name:	Eurotherm Recorders Limited
Manufacturer's address	Dominion Way, Worthing, West Sussex, BN14 8QL, United Kingdom.
Product type:	Data acquisition system
Models:	4000R (Status level I4 or higher)
Safety specification:	EN61010-1: 1993 / A2:1995
EMC emissions specification:	EN50081-2 (Group1; Class A)
EMC immunity specification:	EN50082-2

Eurotherm Recorders Limited hereby declares that the above products conform to the safety and EMC specifications listed. Eurotherm Recorders Limited further declares that the above products comply with the EMC Directive 89 / 336 / EEC amended by 93 / 68 / EEC, and also with the Low Voltage Directive 73 / 23 / EEC

Signed: PRL de la Nougerède Dated: 18-12-96

Signed for and on behalf of Eurotherm Recorders Limited
Peter De La Nougerède
(Technical Director)



IA249986U160 Issue 2 Dec 96

© 1997 Eurotherm Recorders Ltd.

All rights are strictly reserved. No part of this document may be reproduced, stored in a retrieval system or transmitted in any form, or by any means, without the prior, written, permission of the copyright owner.

Eurotherm Recorders Ltd reserves the right to alter the specification of its products from time to time without prior notice. Although every effort has been made to ensure the accuracy of the information contained in this manual, it is not warranted or represented by Eurotherm Recorders Ltd. to be a complete or up-to-date description of the product.

SAFETY NOTES

WARNING!

Any interruption of the protective conductor inside or outside the apparatus, or disconnection of the protective earth terminal is likely to make the apparatus dangerous under some fault conditions. Intentional interruption is prohibited.

Note: In order to comply with the requirements of safety standard BS EN61010, the recorder shall have one of the following as a disconnecting device, fitted within easy reach of the operator, and labelled as the disconnecting device.







- a. A switch or circuit breaker which complies with the requirements of IEC947-1 and IEC947-3
- b. A separable coupler which can be disconnected without the use of a tool
- c. A separable plug, without a locking device, to mate with a socket outlet in the building

1. Whenever it is likely that protection has been impaired, the unit shall be made inoperative and secured against unintended operation. The nearest manufacturer's service centre should be consulted for advice.
2. Any adjustment, maintenance and repair of the opened apparatus under voltage, should be avoided as far as possible and, if inevitable, shall be carried out only by a skilled person who is aware of the hazard involved.
3. The mains (supply voltage) wiring must be terminated in such a way that, should it slip in the cable clamp, the Earth wire would be the last wire to become disconnected.
4. Where conductive pollution (e.g. condensation, carbon dust) is likely, adequate air conditioning/filtering/sealing etc. must be installed in the recorder enclosure.
5. Signal and supply voltage wiring should be kept separate from one another. Where this is impractical, shielded cables should be used for the signal wiring. Where signal wiring is carrying (or could carry under fault conditions), hazardous voltages * double insulation should be used.
6. If the equipment is used in a manner not specified by the manufacturer, the protection provided by the equipment might be impaired.
7. For both portable and panel/rack mounted equipment, the protective earth terminal must remain connected (even when the recorder is isolated from the mains supply), if any of the I/O circuits are connected to hazardous voltages*.

* A full definition of "Hazardous" voltages appears under 'Hazardous Live' in BS EN61010. briefly, under normal operating conditions, hazardous voltages are defined as > 30V RMS (42.4V peak) or > 60V dc.

SYMBOLS USED ON THE RECORDER LABELLING

One or more of the symbols below may appear on the recorder labelling.

	Refer to the Manual for instructions
	Protective Earth
	This recorder for ac supply only
	This recorder for dc supply only.
	This recorder for either ac or dc supply
	Risk of electric shock

DATA ACQUISITION I/O RACK

MANUAL SUPPLEMENT

LIST OF CONTENTS

Section	Page
SAFETY NOTES	2
SYMBOLS USED ON THE RECORDER LABELLING	2
1 INTRODUCTION	4
1.1 OVERVIEW	4
1.1.1 Options	4
1.1.2 Logs	4
1.1.3 Channel trace	4
1.1.4 Messages	4
1.1.5 Jobs	4
1.1.6 Event sources	4
1.1.7 Other items	5
2 CONFIGURATION TRANSFER	5
2.1 TRANSFER WITH A 250MM RECORDER	5
2.2 TRANSFER WITH A HOST COMPUTER	5
3 INSTALLATION	6
3.1 MECHANICAL DETAILS	6
3.2 REMOTE DISPLAY MECHANICAL DETAILS	9
3.2.1 Panel mounting version	9
3.2.2 Wall mounting version	10
3.3 ELECTRICAL INSTALLATION	11
3.4 REMOTE DISPLAY POWER	12
4 SPECIFICATION	13
4.1 GENERAL SPECIFICATION	14
4.2 UNIVERSAL 8-CHANNEL INPUT BOARD SPECIFICATION	15
4.2 16-CHANNEL DC INPUT BOARD SPECIFICATION	17
4.4 RELAY OUTPUT BOARD SPECIFICATION	18
4.5 ANALOGUE OUTPUT BOARD SPECIFICATION	18
5 LIST OF EFFECTIVE PAGES	19



YEAR 2000 COMPLIANCE

All software versions of this product comply with the requirements of the British Standards Institute document 'Disc PD2000-1. A Definition of Year 2000 Conformity Requirements', when the product is used as specified in this manual.

I/O RACK SUPPLEMENT

1 INTRODUCTION

This unit is a rack or panel mounting data acquisition system, capable of supporting up to 96 input channels and up to 96 derived channels (optional). The unit can be used without an operator interface, or it can be supplied with a display/keyboard fitted to the door or, alternatively, a remote display/keyboard or a graphics display unit can be connected to the communications module at the rear of the instrument. Data archiving and configuration save / restore memory card options can be fitted if required.

This document is intended as a supplement to the Chart Recorder Installation and Operating manual(s) supplied with the unit, to point out the ways in which the I/O rack differs from the chart recorder.

1.1 OVERVIEW

1.1.1 Options

Rolling memory and the chart copy and report replay memory card options are not supported.

1.1.2 Logs

Logging is available only if one of the Memory card archiving options (ASCII or PACKED) is fitted to the rack, or to the graphics display option (if fitted).

1.1.3 Channel trace

Operator control and configuration of : print zone, chart span, scale, pen colour, line thickening, dot density, adaptive recording, interpolation and trace enable is allowed only if the graphics display unit is fitted.

1.1.4 Messages

Operator messages can be edited, but can be 'printed' only if the graphics display unit is fitted.

Automatic alarm message configuration is possible only if a graphics display unit is fitted.

1.1.5 Jobs

All 'Trace' jobs are removed unless the graphics display unit is fitted.

The 'Scale Dump' Job is always removed

The 'Send Message N to Chart' job is removed unless the graphics display unit is fitted.

All 'Logging' jobs are removed unless one of the memory card archiving options (ASCII or PACKED) is fitted. The 'Change to Log Interval B' job is removed

All 'Chart' jobs are removed.

1.1.6 Event sources

The 'paper-out' and 'writing system failure' system errors and event sources are removed.

1 OVERVIEW (Cont.)

1.1.7 Other items

- The Chart Calibration menu is removed
- The Print menu is removed
- The Printer Test is removed from diagnostics

2 CONFIGURATION TRANSFER

A 9-way D-type socket for XMODEM comms is located to the right-hand side of the rack, and is accessible with the door open, as shown in figure 3.2a. The communications parameters are fixed as follows:

Start bits: 1, Stop bits: 1, Data bits: 8, Parity: None, Baud rate: 9600.

2.1 TRANSFER WITH A 250mm RECORDER

The use of the 9-way D-type Configuration Transfer connector is changed in that the I/O rack attempts to communicate continuously, rather than wait for SAVE or RESTORE instructions, as with recorders. The transfer of configuration between the I/O rack and a recorder can still be carried out under the control of the recorder, but will not contain any chart etc. data. Transfer with 180mm recorders is not possible.

2.2 TRANSFER WITH A HOST COMPUTER

The I/O rack tries periodically to initiate receipt of a file via XMODEM and is capable of identifying four types of file as described below. If the file received does not match any of these types, transfer is cancelled. The communications parameters are fixed, as listed above.

1. Configuration file. On receipt of a configuration file, the rack is configured accordingly.
2. Autoconfigure file. This file consists of the text *Autoconfigure*. On receipt of such a file, the I/O rack carries out an Autoconfigure operation.
3. Default file. This file consists of the text *Default*. On receipt of a default file, the I/O rack is returned to factory configuration.
4. Slot configuration file. This consists of the text *Slot configuration* on the first line, followed by a line for each slot used, in the format XYZ, where:

- X = I/O board address 1 to F, as shown in table 2.2.
- Y = 0 to 8 and represents card type as follows:
 - 0 = 8 channel universal input board
 - 1 = Relay output board
 - 2 = 16 channel dc input board (takes two addresses)
 - 3 = Comms
 - 4 = Test
 - 6 = Network (takes two addresses)
 - 7 = 8 channel analogue output
 - 8 = 4 channel analogue output
- Z = 0 or 1 according as the slot is disabled (0) or enabled (1).

Address	Channel Numbers	Address	Channel Numbers
0	Invalid	8	57 to 64
1	1 to 8	9	65 to 72
2	9 to 16	A	73 to 80
3	17 to 24	B	81 to 88
4	25 to 32	C	89 to 96
5	33 to 40	D	Relay only
6	41 to 48	E	Relay only
7	49 to 56	F	Relay only

Table 2.2 Channel addressing

The end of the file is indicated by the sending of '0'.

On receipt of a slot configuration file, the instrument will autoconfigure to the requested slot contents. If a request for a file is received, a configuration file is transmitted as normal.

3 INSTALLATION

3.1 MECHANICAL DETAILS

Figure 3.1a shows dimensional details. Figures 3.1b, 3.1b and 3.1c shows the locations of the major functional parts of the unit which is designed to fit into a 19" rack, and is 6U in height.

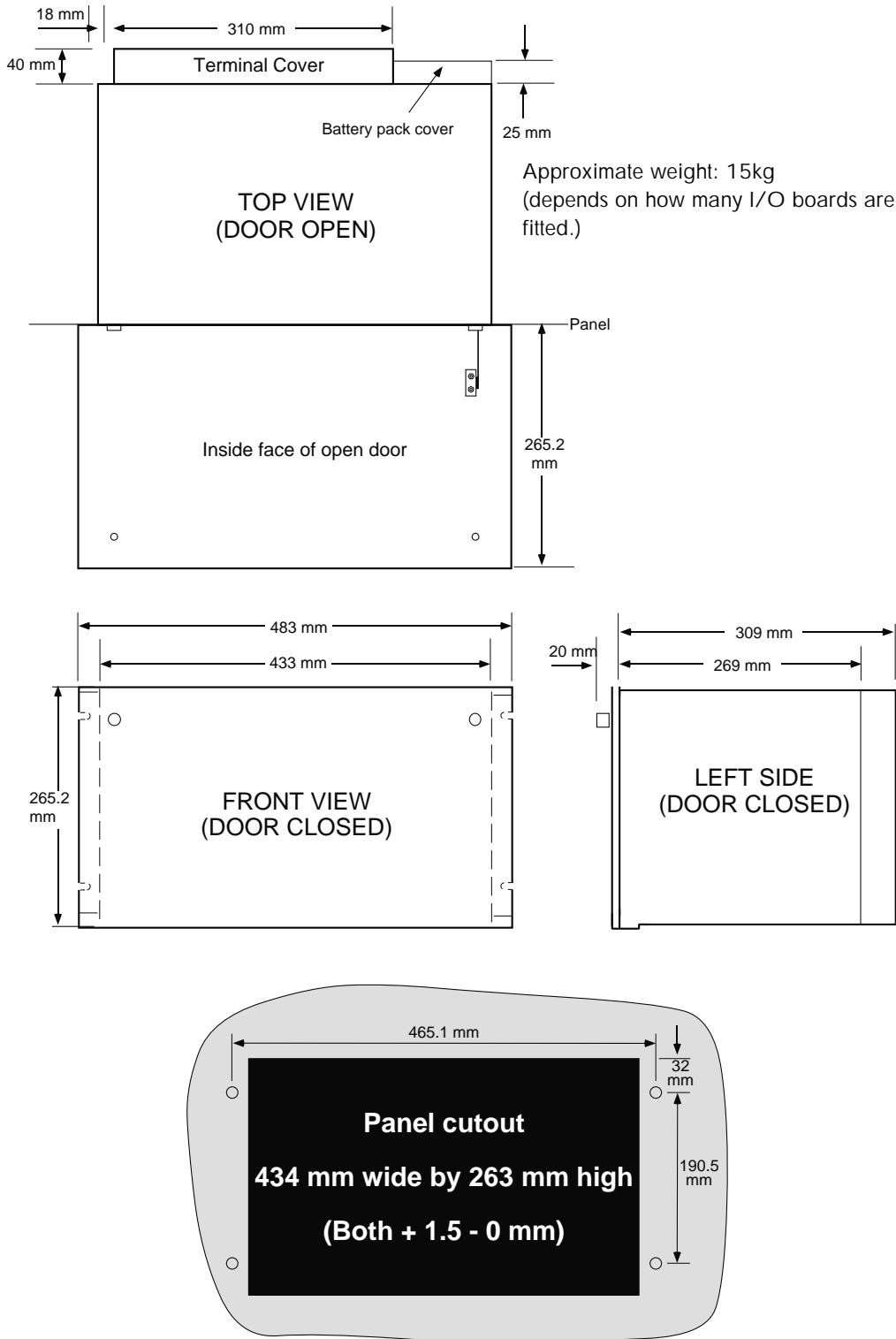

Figure 3.1a Mechanical installation

3.1 MECHANICAL DETAILS (Cont.)

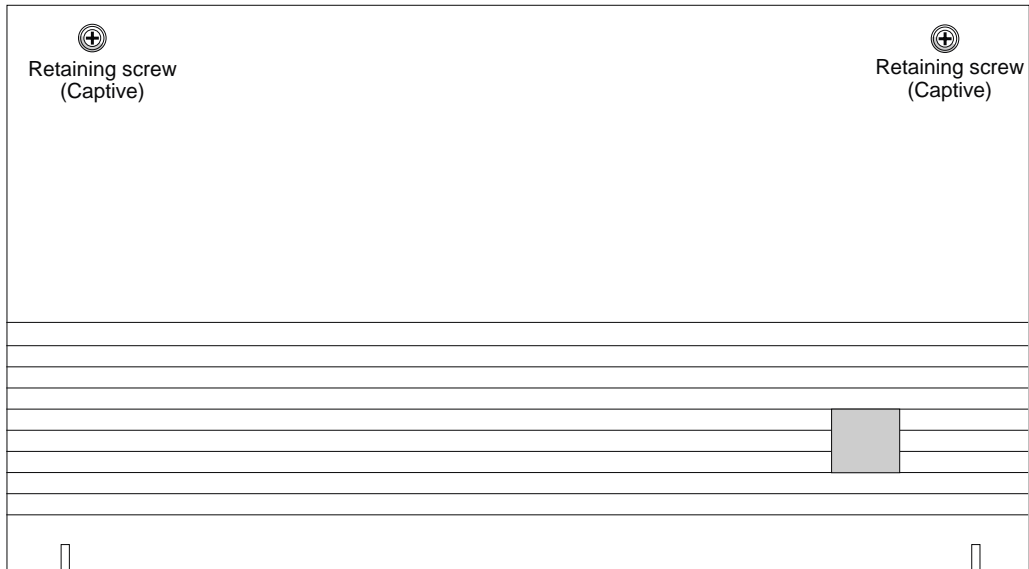

Figure 3.1b Front view (door closed)

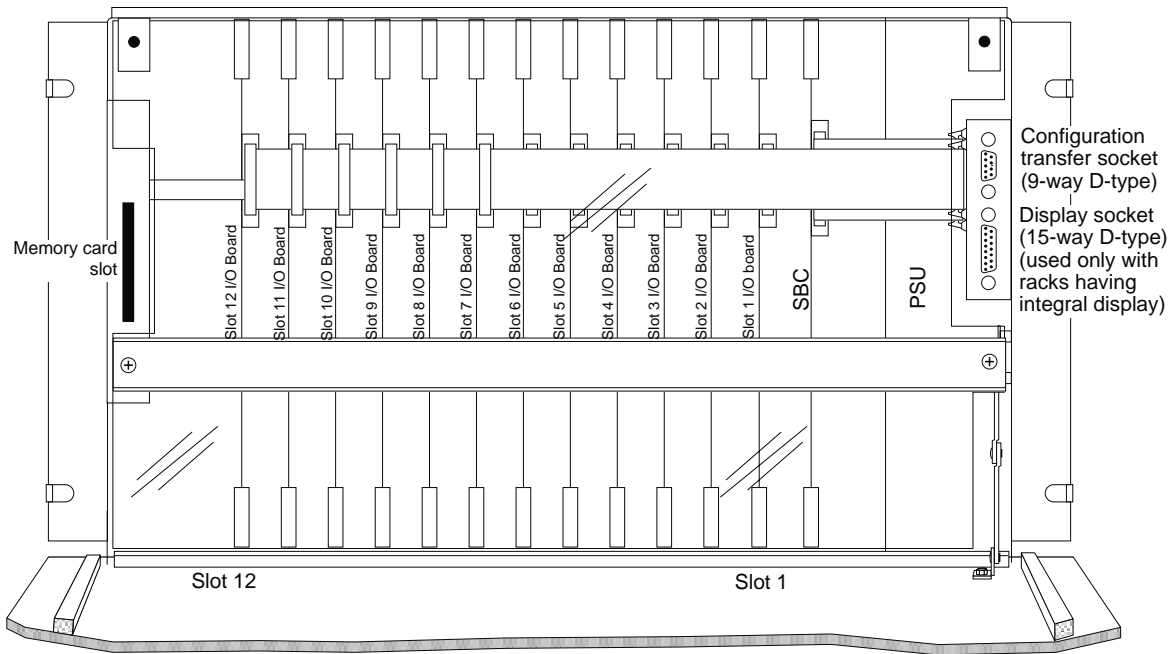

Figure 3.1c Front view (door open)

3.1 MECHANICAL DETAILS (Cont.)

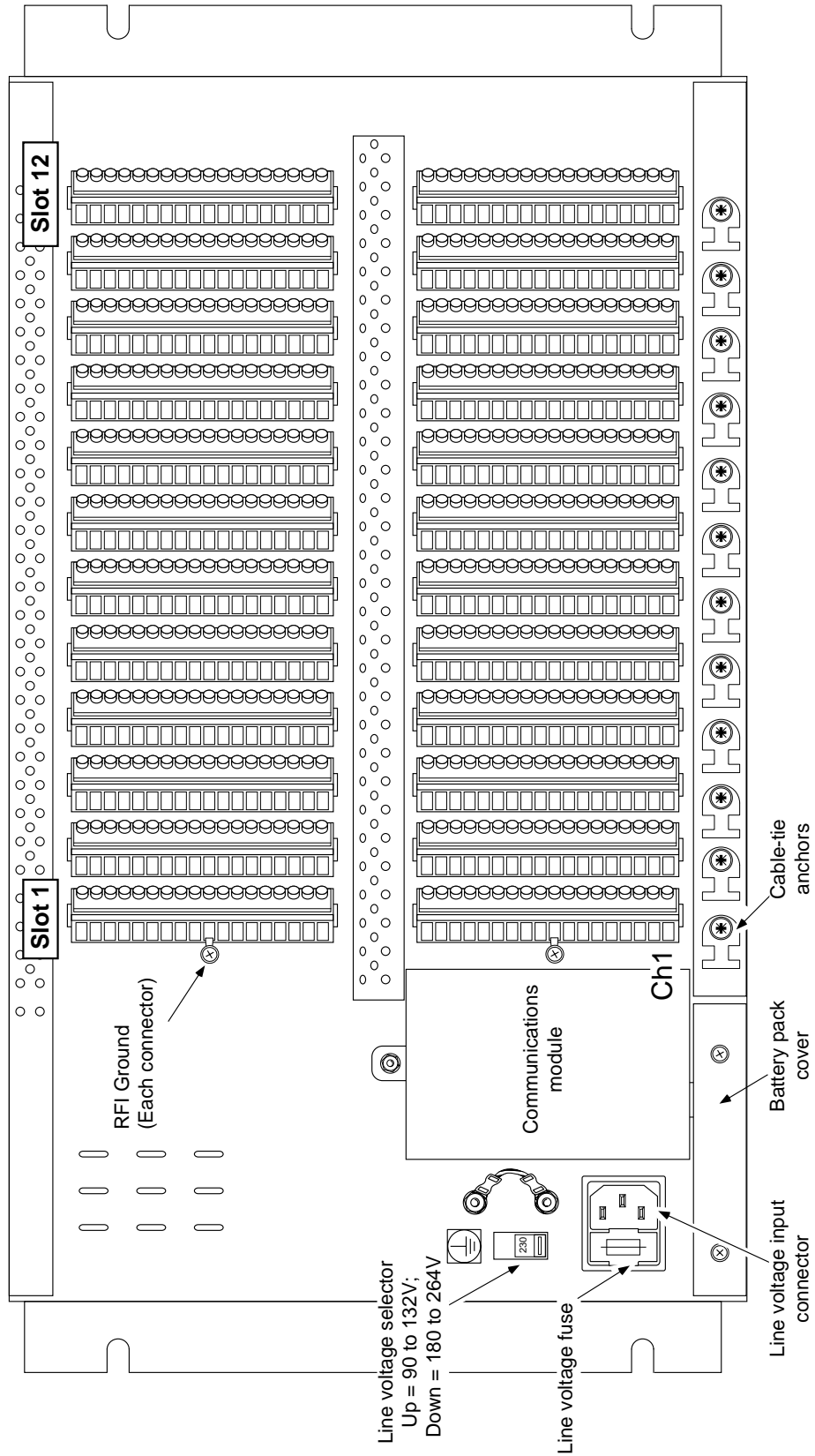

Figure 3.1d Rear View (Terminal cover removed)

3.2 REMOTE DISPLAY MECHANICAL DETAILS

The remote display / keyboard is available as panel mounting or as wall mounting.

3.2.1 Panel mounting version

Figure 3.2.1 shows dimensional details of the panel mounting version. To mount the unit, insert it (cable first) into the aperture. Insert the dovetail slides and tighten the clamping screws.

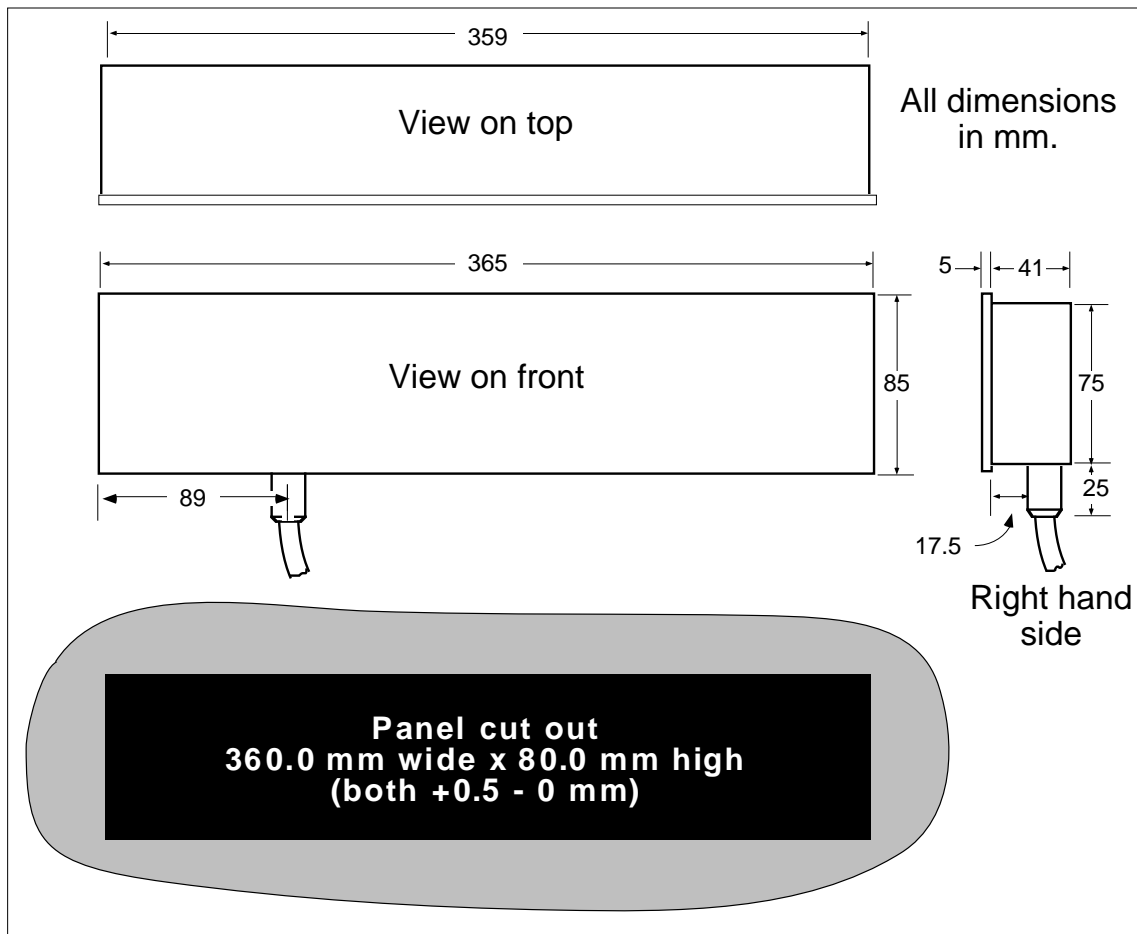

Figure 3.2.1 Panel mounting unit dimensions

3.2.2 Wall mounting version

Figure 3.2.2 shows dimensional details of the wall mounting unit.

To install the unit, two fixing holes have to be drilled in the wall 259 mm apart, as shown in figure 3.2.2.

The support plate can now be fixed to the wall, and the display unit placed on the lower bracket.

Fit the upper bracket behind the display, from the top, and secure the whole assembly using the two side plates supplied.

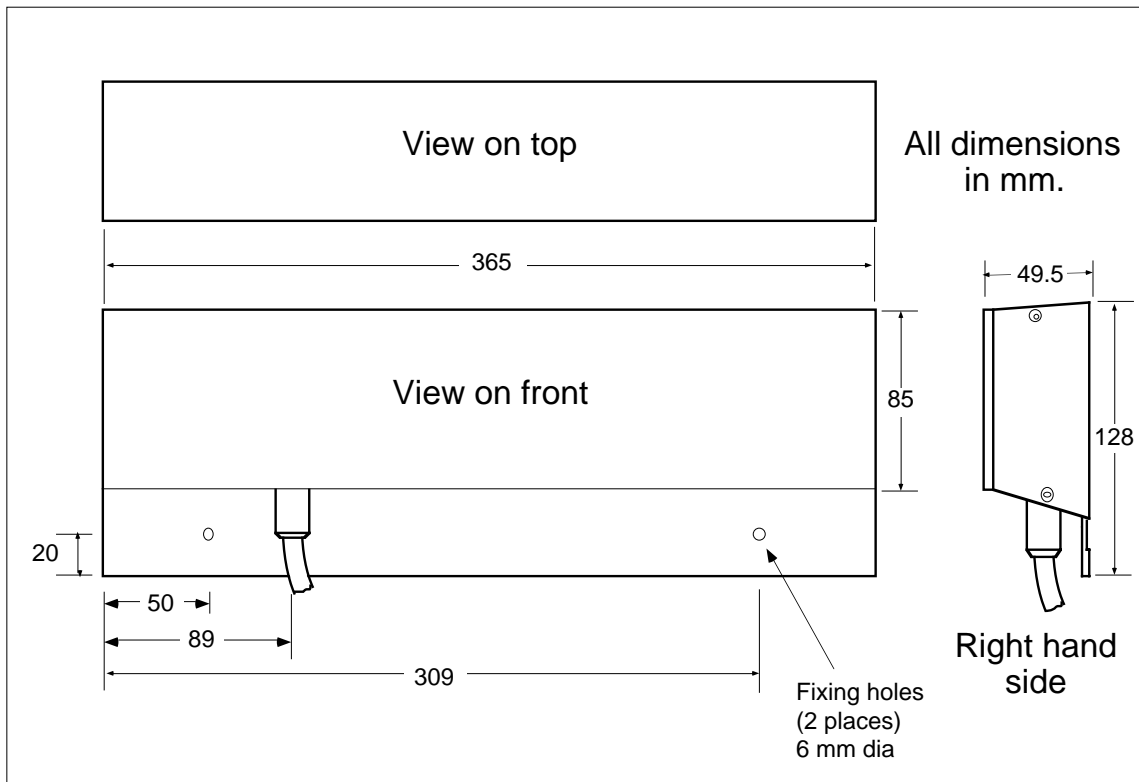

Figure 3.2.2 Wall mounting unit dimensions

3.3 ELECTRICAL INSTALLATION

Mains wiring and voltage selection is as described in the Installation and operation manual, the relevant components being located as shown in figure 3.1d above.

Wiring to the I/O board terminals is as described in the Installation and Operation Manual, except that some items (e.g. the communications module) are located differently, and there are more I/O slots.

Connection with a remote display/keyboard is via the I/O rack communications module, using the integral cable and connector supplied with the display/keyboard unit.

Connection with a graphics display unit is by means of a cable between the I/O rack communications module, and the lower terminal block inside the display unit as shown in figures 3.3a , 3.3b and 3.3c. This cable is not supplied by the manufacturer.

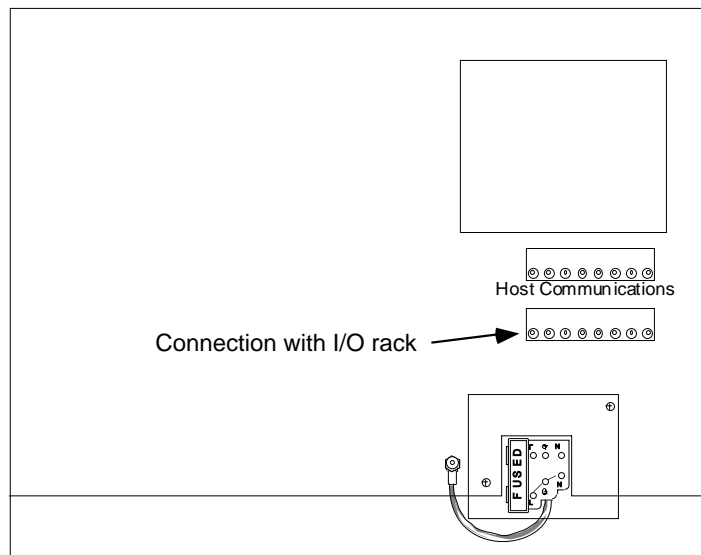

Figure 3.3a View of graphics unit with door open

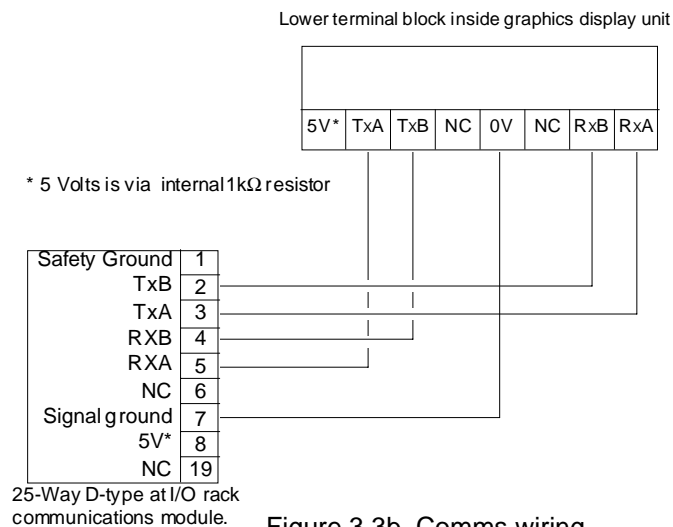

Figure 3.3b Comms wiring
(Non isolated comms - 25-way D-type)

3.3 ELECTRICAL INSTALLATION (Cont.)

When using the isolated version of the communications module (two 9-way D-type connectors fitted), the 0V line must be connected to earth at one point (ONLY) in the communications link. This may be done conveniently at the graphics display unit by connecting the 0V terminal to the earth stud.

Note: Only the male connector (with pins) may be used for host communications

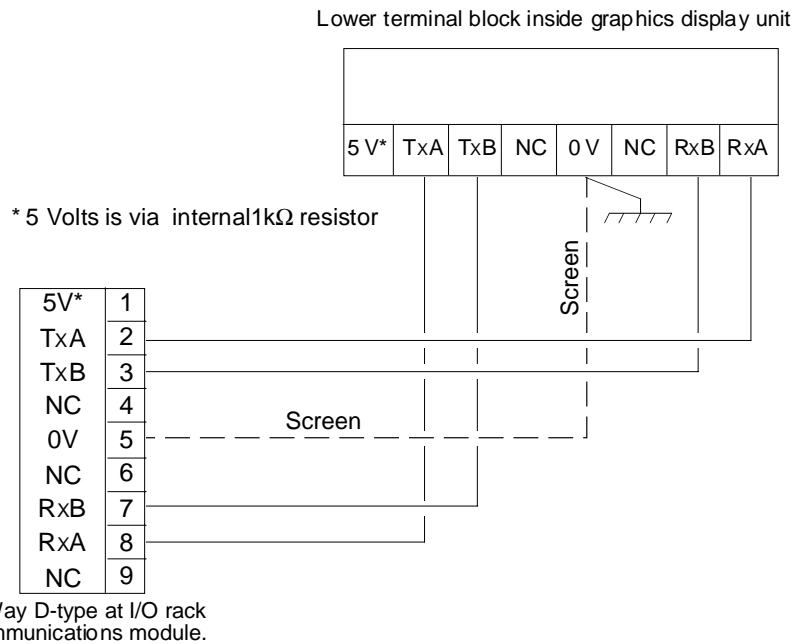

Figure 3.3c Graphics display unit to I/O rack Comms wiring (RS422/485)
(Isolated comms: 9-way D-type)

3.4 REMOTE DISPLAY POWER

The remote display can be located up to 1200 metres from the data acquisition unit. For distances greater than 10 meters, however, a separate power supply unit (PSU) is required to ensure that the remote display runs at full brightness. This PSU is required to source 24V ±10% at up to 500mA, and is connected across pins 9 (24V) and 6(0V) of the display's flying lead connector.

Figure 3.4 and table 3.4, below, give wiring details for the PSU and for the interconnecting data cable between the flying plug of the display and the fixed socket of the data acquisition unit's communications module.

Notes:

1. Data cable type: High quality, screened, twisted pairs
Power cable: 7/0.2 (0.22mm²) (24AWG) minimum.
2. The data lines must have 200Ω, 0.25W (min.) terminating resistors connected across them as shown in figure 3.4
3. Cable screens must be earthed at the data acquisition unit end. (The unit's chassis may be used, as it is connected to safety earth.)
4. If (with the data acquisition unit powered) the display power is switched off, then on again, it may be necessary to make an initial key stroke to re-illuminate the display.
5. When data acquisition unit power is removed, the remote display unit continues to display the last data sent until its own power is removed, or until power is re-applied to the data acquisition unit.

3.4 REMOTE DISPLAY POWER (Cont.)

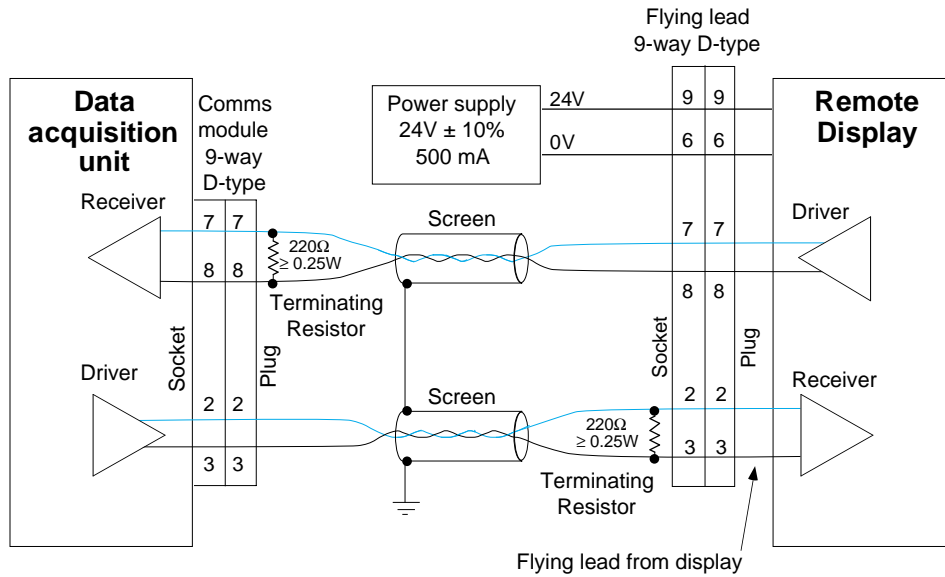

Figure 3.4 remote PSU wiring details

Comms Module	Remote display flying lead
1	1
2	2
3	3
4	4
5	5
6	6
7	7
8	8
9	9
	0V
	+24V

Table 3.4 Pinout details

4 SPECIFICATION

INSTALLATION CATEGORY AND POLLUTION DEGREE

This product has been designed to conform to BS EN61010 installation category II and pollution degree 2. These are defined as follows:

INSTALLATION CATEGORY II

The rated impulse voltage for equipment on nominal 230V mains is 2500V.

POLLUTION DEGREE 2

Normally, only non-conductive pollution occurs. Occasionally, however, a temporary conductivity caused by condensation shall be expected.

4.1 GENERAL SPECIFICATION

I/O Board types

Input board types	8-channel universal input; 16-channel dc input
Output board type	8-channel relay output; 4/8 channel analogue output
Max. number of I/O boards per type	12 off 8-channel i/p; 6 off 16-channel i/p 6 off 8-channel analogue o/p; 12 off 4-channel analogue o/p; 12 off relay o/p
Max number of inputs	96 dc inputs; 96 resistance inputs; 96 contact closure.
Max number of outputs	Relays: 8 x no of free slots; Analogue outputs: 48 in any combination of 4- or 8-channel boards

Environmental Performance

Temperature limits	Operation:	0 to + 50 °C
	Storage:	-20 to +70 °C
Humidity	Operation/Storage:	5 to 85% RH; non-condensing
Maximum altitude		< 2000 metres
Protection		IP54
Shock		BS EN61010
Vibration		2g peak at 10 to 150 Hz

Electromagnetic compatibility (EMC)

Emissions	BS EN50081-2
Immunity	BS EN50082-2

Electrical Safety

BS EN61010	Installation category II; Pollution degree 2 (See page 13 for definitions)
------------	--

Physical (main unit)

Door	265.2 mm. high x 483 mm. wide.
Panel cutout size	263 mm high x 434 mm. wide. (+ 1.5 mm. - 0 mm.)
Depth behind bezel rear face	309 mm. (inc. rear cover); 269 mm. (no rear cover)
Weight (Eight-channel instrument)	20 kg. max.
Panel mounting angle	No restriction

Physical (panel mounted display unit)

Bezel	365 mm wide x 85 mm high
Body	359 mm wide x 75 mm high
Panel cutout	360 mm wide x 80 mm high (both +0.5 mm - 0 mm)
Depth behind front face of panel	41 mm

Physical (wall mounted display unit)

Mounting plate	365 mm wide x 128 mm high
Unit	365 mm wide x 85 mm high
Fixing centres (6 mm fixings)	259 mm; 20 mm from lower edge of mounting plate
Height in front of panel	49.5 mm

Power requirements:

Line voltage (45 to 65 Hertz)	90 to 132 Volts or 180 to 264 Volts (User selectable).
Maximum power	120 W
Fuse type	Ceramic 20 mm. 3.15 Amp. Fast blow.
Interrupt protection	100 ms at 60% load.

Memory protection

	EEPROM (for configuration)
	Battery-supported RAM for clock, totalisers etc.
RAM / clock-support battery type	Nickel-Cadmium (rechargeable)
Support period (no power to unit)	3 months min. at 25 °C; 1 month min. at 50 °C.

4.2 UNIVERSAL 8-CHANNEL INPUT BOARD SPECIFICATION

General specification

Number of inputs	8
Termination	Edge connector / terminal block
Input types	DC Volts, dc millivolts, dc milliamps (with shunt). Thermocouple, Resistance thermometer (2- or 3-wire), Ohms, Contact closure
Input type mix	User selectable during channel configuration.
Measurement frequency	All channels in 1 second
Step response to within resolution	2 seconds
Noise rejection	Common mode: 150dB above 45 Hz. (channel-channel and channel-ground.) Series mode: 67dB above 45 Hz.
Maximum common mode voltage	250 Volts
Maximum series mode voltage	10 mV at lowest range; 500 mV peak at highest range.
Isolation (dc to 65 Hz; BS EN61010)	Installation category II; Pollution degree 2 (See Page 13 for definitions) 300 V channel-to-channel (double isolation) and channel-to-ground (basic isolation)
Dielectric strength	2350 V ac (channel-to-channel) 1350V ac (channel-to-ground) (both 1 minute type-tests)
Insulation resistance	50 MΩ at 500V dc.
Input impedance	>10 MΩ (68.8kΩ for 10V range)
Over-voltage protection	60 Volts peak, 500 V through 50 kΩ resistor
Open cct. detection (to 200 mV range)	65 nA current max.; 8 seconds recognition time (max.); 40 MΩ minimum break resistance.

DC input ranges

Ranges available	-10 to +40 mV; -50 to 200 mV; -500 mV to +1 V; -5 V to +10 V
Temperature performance (worst case)	
-10 to + 40 mV	(80ppm of reading + 27.9ppm of range)/°C
-50 to + 200 mV	(80ppm of reading + 12.4ppm of range)/°C
-0.5 to + 1.0 V	(80ppm of reading + 2.1ppm of range)/°C
-5 to + 10V (100V with attenuator)	(272ppm of reading + 4.7ppm of range)/°C
Shunt/Attenuator	Externally mounted resistor modules
Additional error due to the above	0.1% (shunt); 0.2% (attenuator).
Performance	See table

Range	Resolution	Performance (worst case) in instrument at 20 °C
-10 mV to + 40 mV	1.4 μV	0.083 % reading + 0.056 % range
-50 mV to + 200 mV	14 μV	0.072% reading + 0.073% range
- 0.5 V to + 1 V	37 μV	0.070% reading + 0.032% range
- 5 to + 10 V	370 μV.	0.223% reading + 0.034% range

Thermocouple data

Linearisation errors	0.15 °C or better
Bias current	<2 nA (<10 nA at 70 °C)
Cold Junction (CJ) types (selectable)	Off, internal, external, remote.
CJ error	1.0 °C or better
CJ rejection ratio	25:1 minimum
Remote CJ	Via any user-selected input channel.
Upscale/downscale drive	Configurable for each channel
Types and ranges	See table

T/C type	Range (°C)	Standard
B	-200 to + 1800	IEC584.1:1977
C	0 to + 2300	Hoskins
E	-200 to + 1000	IEC584.1:1977
J	-200 to + 1200	IEC584.1:1977
K	-200 to + 1370	IEC584.1:1977
L	-200 to + 900	DIN 43710
N	-200 to + 1300	IEC584.1:1977
R	-200 to + 1760	IEC584.1:1977
S	-50 to + 1760	IEC584.1:1977
T	-250 to + 400	IEC584.1:1977
U	-100 to + 600	DIN43710-85
NiNiMo	0 to + 1300	Eurotherm Recorders
Platinel II	-100 to + 1300	Engelhard R83

Continued

4.2 Universal input board specification (Cont.)

3-wire RTD data

RTD linearisations Pt100, Pt1000, Cu10, Ni100, Ni120
 Linearisation errors 0.012 °C or better
 Influence of lead resistance error: 0.15 % of lead resistance
 mismatch: 1 ohm per ohm.
 Types and ranges See table

RTD type	Range (°C)	Standard
Pt 100	-200 to +850	IEC751: 1981
Pt1000	-200 to +850	Based on IEC751: 1981
Cu 10	-20 to +250	General Electric
Ni 100	-50 to +170	DIN43760
Ni 120	-50 to +170	Based on DIN 43760

Typical Pt₁₀₀ figures

See table below

Range °C	Resolution	Performance (worst case) in instrument at 20 °C
-200 to +200	0.02 °C	0.033% reading + 0.32 °C
-200 to +1000	0.14 °C	0.033% reading + 1.85 °C

Ohms ranges

Ranges available 0 to 180Ω; 0 to 1.8kΩ; 0 to 10.0kΩ
 Temperature performance (worst case)
 0 to 180Ω (35ppm of reading + 34.3ppm of range)/°C
 0 to 1.8kΩ (35ppm of reading + 14.6ppm of range)/°C
 0 to 10kΩ (35ppm of reading + 1.9ppm of range)/°C

Range	Lead resistance	Resolution	Performance (worst case) in instrument at 20 °C
0 to 180 Ω	10 Ω	5 mΩ	0.033% reading + 0.070% range
0 to 1.8 kΩ	10 Ω	55 mΩ	0.033 % reading + 0.041 % range
0 to 10 kΩ	10 Ω	148 mΩ	0.037 % reading + 0.020 % range

Other linearisations

Tables available $\sqrt{\text{value}}$; $(\text{value})^{3/2}$; $(\text{value})^{5/2}$; User defined tables (up to 3 off)

Contact closure (switch) inputs

Type Volt-free contact
 Wetting voltage 2.5 Volts nominal
 Minimum latched pulse width 125 ms.
 De-bounce Inherent 1 second.

4.2 16-CHANNEL DC INPUT BOARD SPECIFICATION

General specification

Number of inputs		16
Termination		Edge connector / terminal block
Input types		DC Volts, dc millivolts, dc milliamps (with shunt). Thermocouple, Contact closure (not channels 1, 8, 16)
Input type mix		Software selected on configuration for each channel*.
Measurement frequency		All channels in 1 second
Step response		1.5 seconds
Noise rejection	Common mode:	150dB above 45 Hz. (channel-channel and channel-ground.)
	Series mode:	> 60dB between 10 to 100 Hz.
Maximum series mode voltage		Hardware range +50 mV.
Safety isolation (BS EN61010)		Installation category II; Pollution degree 2 (See Page 13 for definitions) 300 V channel-to-channel (double isolation) and channel-to-ground (basic isolation)
Dielectric strength		2350 V ac (channel-to-channel); 1350V ac (channel-to-ground) (both 1 minute type-tests).
Input impedance		> 10 MΩ (68.8kΩ for 5V range)
Over-voltage protection		60 Volts peak, 500 V through 50 kΩ resistor
Open cct. detection (85 mV range only)		65 nA current (max.); 8 seconds recognition time (max.); 40 MΩ minimum break resistance.
Damping		2, 4, 8, 16, 32, 64, 128 or 256 secs. time constant, as configured. Damping improves o/p noise and performance figures listed in the table below.

* Maximum of eight different linearisations (seven + linear) allowed per board.
Contact closure inputs not available on channels 1, 8 and 16.

DC input ranges

Ranges available		-15mV to +85 mV; -1.0 V to +5 V
Temperature performance (worst case)		
	-15mV to + 85mV	(80 ppm of reading + 12.9 ppm of range)/°C
	-1V to + 5V	(272 ppm of reading + 7.8 ppm of range)/°C
Shunt		Externally mounted resistor modules
Additional error due to shunt		0.1%.
Typical performance		See table below

Range	Resolution	Performance (worst case) in instrument at 20°C
-15 mV to + 85 mV	± 5.5 µV	0.072% reading + 0.071% range
- 1.0V to + 5 V	± 280µV	0.223% reading + 0.055 range

Thermocouple data (in addition to the above)

Linearisation errors	0.15 °C or better
Bias current	< 2 nA (< 10 nA at 70 °C)
Cold Junction (CJ) types (selectable)	Off, internal, external, remote.
CJ error	1 °C or better
CJ rejection ratio	25:1 minimum
Remote CJ	Via any user-selected input channel.
Upscale drive	Configurable for each channel
Types and ranges	As for 8-channel input board above.

Other linearisations

Tables available	$\sqrt{\text{value}}$; $(\text{value})^{3/2}$; $(\text{value})^{5/2}$; User defined tables (up to 3 off)
------------------	---

Contact closure (switch) inputs (not available for channels 1, 8 and 16)

Type	Volt-free contact
Wetting voltage	2.5 Volts nominal
Minimum latched pulse width	250 ms.
De-bounce	Inherent 1 second.

4.4 RELAY OUTPUT BOARD SPECIFICATION

No of relays per board	Eight	
Contact format	Single pole change-over (single set of common, normally open and normally closed contacts)	
Estimated life at 60VA load	1,000,000 operations	
Max contact voltage*	250 Volts ac.	
Max contact current*	Make:	8 Amps
	Continuous:	3 Amps
	Break:	2 Amps
Maximum switchable power*	60 watts or 500 VA	
Isolation (BS EN61010)	Installation category II; Pollution degree 2 (See Page 13 for definitions)	
	300V ac channel-to-channel (double isolation) and channel-to-ground (basic isolation)	
	300V ac channel-to-ground (basic isolation)	
Dielectric strength (1 minute type-tests)	1350V ac (contact to contact)	
	2350V ac (channel to channel)	
	1350V ac (channel to ground)	

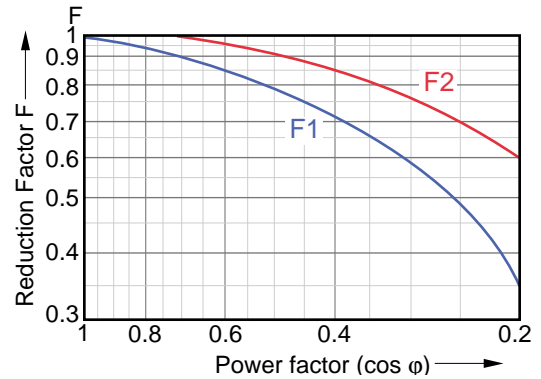

Figure A4 Derating curves

* With resistive loads; derate with reactive or inductive loads as per figure A4, in which:

F1 = Actually measured on representative samples

F2 = Typical values (according to experience)

Contact life = Resistive contact life x Reduction factor.

4.5 ANALOGUE OUTPUT BOARD SPECIFICATION

General specification

Number of outputs	Four or eight as ordered	
Termination	Edge connector / terminal block	
Output types	Current or Voltage as configured for each channel	
	Current:	0 to 25mA max. at up to 24 V
	Voltage:	-1 to 11V at up to 5 mA
Output frequency	All channels in 1 second	
Output damping	250msec rise time (10% to 90%)	
Resolution	0.025% full scale, monotonic.	
Isolation (dc to 65 Hz; BS EN61010)	Installation category II; Pollution degree 2 (see Page 13 for definitions)	
	Channel to channel:	300V RMS or dc (double isolation)
	Channel-to-ground:	300V RMS or dc (basic isolation)
Dielectric strength (BS EN61010)	(1 minute type tests)	
	Channel to channel:	2350 V ac
	Channel to ground:	1350V ac
Insulation resistance	50 MΩ at 500V dc.	

4.6 COMMUNICATIONS SPECIFICATION

Isolated Communications Module

Safety Isolation (dc to 65Hz; BS EN61010)	Installation category II; Pollution degree 2 (see Page 13 for definitions)	
Terminals to ground	30V RMS or dc (double insulation)	

Non isolated communications Module

All voltages are SELV-E (Separate Extra Low Voltage - Earthed) <30 V RMS (42.4 V peak) or < 60 V dc.

Note: Non isolated communications options appeared only on early 250mm recorders, and are distinguishable by having a single 25-way D-type connector, instead of the two nine-way D-type connectors fitted to the isolated communications module.

5 LIST OF EFFECTIVE PAGES

This manual consists of the following pages at their specified issue numbers.

Page 1	Issue 3 Oct 97	Page 11	Issue 2 Apr 97
Page 2	Issue 3 Oct 97	Page 12	Issue 4 mar 98
Page 3	Issue 4 Mar 98	Page 13	Issue 4 Mar 98
Page 4	Issue 2 Apr 97	Page 14	Issue 3 Oct 97
Page 5	Issue 2 Apr 97	Page 15	Issue 4 Mar 98
Page 6	Issue 2 Apr 97	Page 16	Issue 4 Mar 98
Page 7	Issue 2 Apr 97	Page 17	Issue 4 Mar 98
Page 8	Issue 2 Apr 97	Page 18	Issue 4 Mar 98
Page 9	Issue 2 Apr 97	Page 19	Issue 4 Mar 98
Page 10	Issue 2 Apr 97		

This page is left deliberately blank

Inter-Company sales and service locations

Australia

Eurotherm Pty. Limited.
Unit 10,
40 Brookhollow Avenue,
Baulkham Hills,
NSW 2153

Telephone: 61 2 9634 8444
Fax: 61 2 9634 8555
Email: vincelen@eurotherm.com.au
or: vince.lendrum@eurotherm.com.au

Austria

Eurotherm Meß-und Regeltechnik GmbH
Geiereckstraße 18/1,
A1110 Wien,

Telephone: 43 1 798 76 01
Fax: 43 1 798 76 05

Belgium

Eurotherm BV,
Herentalsebaan 71-75,
B 2100 Deurne
Antwerpen

Telephone: 32 3 322 3870
Fax: 32 3 321 7363

Denmark

Eurotherm Danmark A/S
Finsensvej 86,
DK 2000 Fredriksberg,

Telephone: 45 38 871622
Fax: 45 38 872124

Finland

Eurotherm Finland,
Auragaten 12A,
FIN-20100 Åbo

Telephone: 358 22 50 60 30/1
Fax: 358 22 50 32 01

France

Eurotherm Chessell
Une division d'Eurotherm Automation SA,
Parc d'affaires,
6, Chemin des Joncs,
BP55
F - 69572 Dardilly, CEDEX

Telephone: 33 4 78 66 45 00
Fax: 33 4 78 35 24 90

Germany

Eurotherm Meßdatentechnik GmbH
Ottostraße 1,
D-65549 Limburg a.d.Lahn

Tel: 49 64 31 9173 0
Fax: 49 64 31 9173 33

Great Britain

Eurotherm Recorders Limited,
Dominion Way,
Worthing,
West Sussex BN14 8QL

Telephone: 01 903 205222
Telex: 877296 CHESEL G
Fax: 01 903 203767

Email: Sales@recorders.eurotherm.co.uk
or: Support@recorders.eurotherm.co.uk
Web: <http://www.eurotherm.co.uk>

Hong Kong

Eurotherm Limited,
Unit D, 18/F Gee Chang Hong Centre,
65, Wong Chuk Hang Road,
Aberdeen.

Telephone: 852 2873 3826
Telex: 69257EIFEL HX
Fax: 852 2870 0148

India

Eurotherm Del India Limited,
152, Developed Plots Estate,
Chennai 600 096,

Telephone: 91 44 4961129
Fax: 91 44 4961831

Italy

Eurotherm SpA,
Via XXIV Maggio,
I-22070 Guanzate,
Como.

Telephone: 39 031 975111
Fax: 39 031 977512

Japan

Eurotherm Business Unit,
Nemic Lambda KK,
Denpa Building,
1-11-15 Higashi Gotanda,
Shinagawa,
Tokyo 141-0022

Telephone: 81 3 3447 6441
Fax: 81 3 3447 6442

Korea

Eurotherm Korea Limited,
J- Building
402-3
Poongnab-Dong,
Songpa-Ku
Seoul, 138-040

Telephone: 82 2 2478 8507
Fax: 82 2 488 8508

Netherlands

Eurotherm BV,
Genielaan 4,
2404CH Alphen aan den Rijn,
The Netherlands

Telephone: 31 172 411 752
Fax: 31 172 417 260

Norway

Eurotherm A/S,
Post Boks 650,
N - 1411 Kolbotn,
Norway,

Telephone: 47 66 803330
Fax: 47 66 803331

Spain

Eurotherm España SA,
Pol. Ind. De Alcobendas,
Calle de la Granja 74,
28108 Alcobendas,
Madrid.

Telephone: 34 91 661 60 01
Fax: 34 91 661 90 93

Sweden

Eurotherm AB,
Lundavägen 143,
S-21224 Malmö.

Telephone: 46 40 38 45 00
Fax: 46 40 38 45 45

Switzerland

Eurotherm Produkte (Schweiz) AG,
Schwerzistraße, 20,
CH-8807 Freienbach.

Telephone: 41 55 415 44 00
Fax: 41 55 415 44 15

United States of America

Eurotherm Recorders Inc.
One Pheasant Run,
Newtown Industrial Commons,
Newtown PA 18940.

Telephone: 1 215 968 0660
Fax: 1 215 968 0662
Web: <http://www.eurotherm.com/chessell>
e-mail: sales@recorders.eurotherm.com



**EUROTHERM
CHESELL**

EUROTHERM RECORDERS LIMITED

A member of the Eurotherm PLC Group of Companies
Dominion Way, Worthing, West Sussex, BN14 8QL
Telephone: 01 903 205222. Telex: 877296. Facsimile: 01 903 203767
e-mail: Sales@recorders.eurotherm.co.uk
e-mail: Support@recorders.eurotherm.co.uk
Website: <http://www.eurotherm.co.uk>

