

4181M



EUROTHERM
CHESSELL

Model 4181M
Chart recorder

User guide

Major functional parts

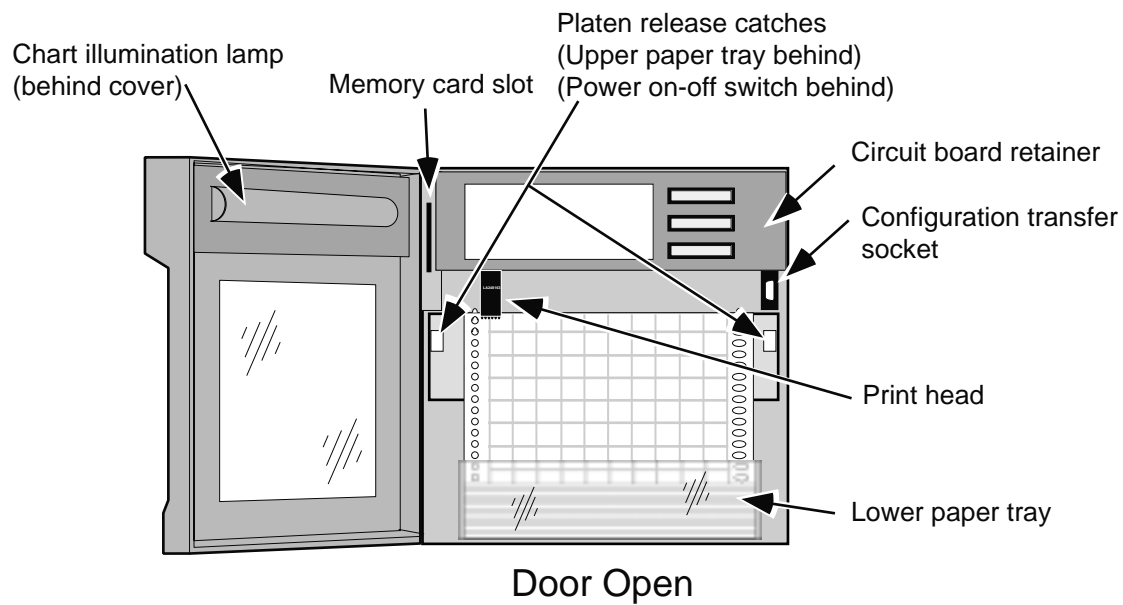
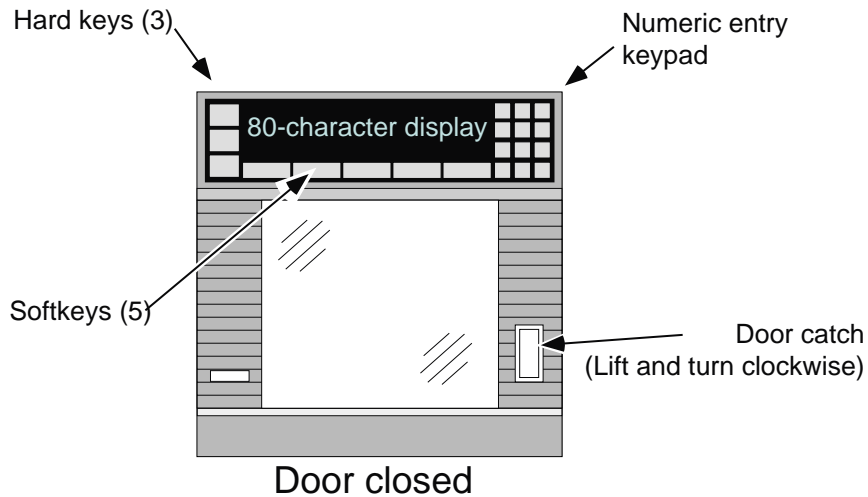

Useful part numbers

PA244816	Battery pack
CH533151	Fuse
LA246843	PC Configuration Tool
HA246958	Communications Manual
HA247361	Memory Card Instruction Manual
HA247733	Graphics Unit Manual
HA248387	Technical Manual
LA246779UK10	100 Shunt
LA246779UK25	250 Shunt
LA244180U100	Input Attenuator
LA249556	6-colour disposable print cartridge (Model 4181)
LA248163	6-colour disposable print cartridge (Model 4180)
GD248010Uxxx	22 metre z-fold chart (xxx = N of chart divisions = 100 or 120)



Declaration of Conformity

Manufacturer's name:	Eurotherm Recorders Limited
Manufacturer's address	Dominion Way, Worthing, West Sussex, BN14 8QL, United Kingdom.
Product type:	Industrial chart recorder
Models:	4180C (Status level F8 or higher) 4180M (Status level K8 or higher) 4181M (Status level A1 or higher)
Safety specification:	EN61010-1:1993/A2:1995
EMC emissions specification:	EN50081-2 (Group 1; Class A)
EMC immunity specification:	EN50082-2

Eurotherm Recorders Limited hereby declares that the above products conform to the safety and EMC specifications listed. Eurotherm Recorders Limited further declares that the above products comply with the EMC Directive 89 / 336 / EEC amended by 93 / 68 / EEC, and also with the Low Voltage Directive 73/23/EEC

Signed:

P. De La Nougerède

Dated: 23-July-98

Signed for and on behalf of Eurotherm Recorders Limited
Peter De La Nouger de
(Technical Director)



© 1998 Eurotherm Recorders Ltd.

All rights are strictly reserved. No part of this document may be reproduced, stored in a retrieval system or transmitted in any form, or by any means, without the prior, written, permission of the copyright owner.

Eurotherm Recorders Ltd. reserves the right to alter the specification of its products from time to time without prior notice. Although every effort has been made to ensure the accuracy of the information contained herein, it is not warranted or represented by Eurotherm Recorders Ltd. to be a complete or up-to-date description of the product.

180 mm MULTIPOINT RECORDER

INSTALLATION AND OPERATION MANUAL

OVERALL CONTENTS LIST

Section	Page
SAFETY NOTES	i - 3
TERMINOLOGY	i - 4
1 INSTALLATION	
1.1 INSTALLATION PROCEDURE	1 - 3
1.2 UNPACKING THE RECORDER	1 - 3
1.3 MECHANICAL INSTALLATION	1 - 3
1.4 SUPPLY VOLTAGE CONNECTION	1 - 3
1.5 SIGNAL WIRING	1 - 6
1.6 CONFIGURATION TRANSFER WIRING	1 - 9
1.7 CHART INSTALLATION /REPLACEMENT	1 - 10
1.8 PRINT CARTRIDGE REPLACEMENT	1 - 11
SECTION 2 BASIC OPERATION	
2.1 FIRST SWITCH ON	2 - 2
2.2 OPERATOR INTERFACE	2 - 34
2.3 CONFIGURATION EXAMPLE	2 - 7
2.4 COPY CONFIGURATION	2 - 16
SECTION 3 OPERATOR MENUS	
3.1 INTRODUCTION	3 - 5
3.2 TOP LEVEL OPERATOR MENU PAGE 1	3 - 6
3.3 TOP LEVEL OPERATOR MENU PAGE 2	3 - 14
3.4 TOP LEVEL OPERATOR MENU PAGE 3	3 - 18
3.5 TOP LEVEL OPERATOR MENU PAGE 4	3 - 20
4 CONFIGURATION	
4.1 INTRODUCTION	4 - 5
4.2 INSTRUMENT CONFIGURATION	4 - 8
4.3 CHART CONFIGURATION	4 - 12
4.4 CHANNEL / ALARM CONFIGURATION	4 - 14
4.5 GROUP CONFIGURATION	4 - 28
4.6 INTERNAL EVENT CONFIGURATION	4 - 29
4.7 LOG CONFIGURATION	4 - 31
4.8 COPY CONFIGURATION	4 - 32
4.9 OPTIONS CONFIGURATION	4 - 33

(Continued)



YEAR 2000 COMPLIANCE

All software versions of non-graphics products, and software versions 2.7 onwards of products with graphics displays, comply with the requirements of the British Standards Institute document 'Disc PD2000-1. A Definition of Year 2000 Conformity Requirements', when the product is used as specified in this manual.

List of Contents (Cont.)

Section	Page
4.10 TRANSFER CONFIGURATION	4 - 33
4.11 DIAGNOSTICS	4 - 34
4.12 AUTOCONFIGURATION	4 - 38
4.13 OPERATOR ACCESS CONFIGURATION	4 - 38
4.14 ADJUST	4 - 41
4.15 PRINT CONFIGURATION	4 - 46
5 OPTIONS	
5.1 INSTALLING NEW OPTIONS	5 - 3
5.2 TOTALISER / COUNTER / TIMER (TCT) OPTION	5 - 4
5.3 MATHS PACK	5 - 10
6 SERVICE	
6.1 CHART ILLUMINATION TUBE REPLACEMENT	6 - 2
6.2 BATTERY REPLACEMENT	6 - 2
7 REFERENCE	
7.1 RECORDER MESSAGES	7 - 2
7.2 COSHH DATA	7 - 4
7.3 LIST OF EFFECTIVE PAGES	7 - 8
7.4 GLOSSARY OF TERMS	7 - 9
ANNEX A RECORDER SPECIFICATION	
A1 GENERAL SPECIFICATION	A - 2
A2 UNIVERSAL 8-CHANNEL INPUT BOARD SPECIFICATION	A - 4
A3 16 CHANNEL DC INPUT BOARD SPECIFICATION	A - 6
A4 RELAY OUTPUT BOARD SPECIFICATION	A - 7
A5 ANALOGUE OUTPUT BOARD SPECIFICATION	A - 7
ANNEX B PREVIOUS RECORDER MODELS	
B1 INTRODUCTION	B - 3
B2 CHART INSTALLATION/REPLACEMENT	B - 4
B3 PRINT CARTRIDGE REPLACEMENT	B - 6
INDEX	

Full sectional contents lists appear at the beginning of each chapter

Safety Notes

1. Whenever it is likely that protection has been impaired, the unit shall be made inoperative and secured against unintended operation. The nearest manufacturer's service centre should be consulted for advice.
2. Any adjustment, maintenance and repair of the opened apparatus under voltage, should be avoided as far as possible and, if inevitable, shall be carried out only by a skilled person who is aware of the hazard involved.
3. The Mains (supply voltage) wiring must be terminated in such a way that, should it slip in the cable clamp, the Earth wire would be the last wire to become disconnected.

WARNING!





Any interruption of the protective conductor inside or outside the apparatus, or disconnection of the protective earth terminal is likely to make the apparatus dangerous under some fault conditions. Intentional interruption is prohibited.

4. Where conductive pollution (e.g. condensation, carbon dust) is likely, adequate air conditioning/filtering/sealing etc. must be installed in the recorder enclosure.
5. This unit contains one or more batteries which must be treated and disposed of with care. In particular, batteries must not be shorted or an explosion can occur. Batteries should be disposed of in accordance with local regulations; they must not be discarded with normal refuse.
6. Signal and supply wiring should be kept separate from one another. Where this is impractical, shielded cables should be used for the signal wiring. Where signal wiring is carrying (or could carry, under fault conditions) hazardous voltages *, double insulation should be used.
7. If the equipment is used in a manner not specified by the manufacturer, the protection provided by the equipment might be impaired.
8. For both portable and panel mounting equipment, the protective earth terminal must remain connected (even when the recorder is isolated from the mains supply) if any of the I/O circuits are connected to hazardous voltages*.

* A full definition of 'Hazardous' Voltages appears under 'Hazardous Live' in BS EN61010. Briefly, under normal operating conditions Hazardous voltage levels are defined as >30V RMS (42.4V peak) or >60V dc.

Symbols used on the recorder labelling

One or more of the symbols below may appear on the recorder labelling.

	Refer to the Manual for instructions
	Protective Earth
	This recorder for ac supply only
	This recorder for dc supply only.
	Risk of electric shock



STATIC ELECTRICITY

High voltages (tens of kilovolts) can be generated on the human skin through a number of mechanisms, such as friction between different materials (e.g. nylon and skin), and separation of similar materials (e.g. masking tape, nylon sheet). The gate-oxide region of all metal oxide semiconductors (MOS) is extremely thin, and can be damaged by voltages as low as 60 Volts. Modern MOS devices have built-in clamp diodes which reduce the incidence of obvious static damage considerably. It is possible however, even with such clamping diodes, to produce a small rupture in the oxide layer. This might not destroy the device immediately, but it may result in a gradual reduction in the performance of the device until, eventually, it fails.

For this reason, the following precautions should be taken when handling any recorder circuit board.

1. Personnel handling MOS devices, or circuit boards containing them, should wear anti-static materials such as cotton. Nylon clothing should be avoided.
2. All bench tops should be covered with conductive material (10^4 to 10^5 Ohms per square) maintained at the recorder chassis potential.
3. Circuit boards removed from the recorder should be placed into a static-safe bag, initially at the recorder chassis potential, for storage. Before re-fitting the board, the containing bag should again be returned to the recorder chassis potential.
4. Personnel handling MOS devices, or boards containing them, should wear a wrist strap connected (via a safety resistor) to the bench top, or if appropriate, to a suitable grounding point on the rack.
5. Leads of MOS devices removed from circuit should be shorted together using conductive foam or similar.
6. MOS devices should not be extracted from or inserted into circuit whilst the circuit board has power applied.

TERMINOLOGY

Anti-static

This term means that the material in question does not of itself generate static electricity. Such materials do not afford protection against external electric fields.

Static safe

This means that the material in question a) does not generate static electricity, and b) any device enclosed in such material is safe from the effects of external electric fields.

SECTION 1: INSTALLATION

LIST OF CONTENTS

Section	page
1.1 INSTALLATION PROCEDURE	1 - 3
1.2 UNPACKING THE RECORDER	1 - 3
1.3 MECHANICAL INSTALLATION	1 - 3
1.4 SUPPLY VOLTAGE CONNECTION	1 - 3
1.4.1 Supply voltage selection	1 - 3
1.4.2 Supply voltage wiring	1 - 5
1.4.3 Supply voltage fuse	1 - 5
1.5 SIGNAL WIRING	1 - 6
1.5.1 The analogue output board as a transmitter power supply	1 - 6
ANALOGUE OUTPUT CHANNEL	1 - 6
ANALOGUE INPUT CHANNEL	1 - 6
1.6 CONFIGURATION TRANSFER WIRING	1 - 9
1.7 CHART INSTALLATION / REPLACEMENT	1 - 10
1.7.1 Old chart removal	1 - 10
1.7.2 Fitting a new chart	1 - 10
1.8 PRINT CARTRIDGE REPLACEMENT	1 - 11

Notes:

1. If the recorder is to be left for an extended period without power applied, it is recommended that the print cartridge be removed from the recorder (section 1.8) and stored separately in a sealed container.
 2. The instrument can weigh up to 20 kg. It is therefore recommended that a risk assessment be carried out before it is handled.
-

Note:

Sections 1.7 and 1.8 describe chart and print cartridge replacement procedures for current recorders. For previous versions of the recorder, see Annex B towards the end of this manual. The two versions of the recorder are distinguished most easily by examining the print cartridge.

As can be seen from the front views shown in the figure below, the two types are visually quite different; they are not physically interchangeable.

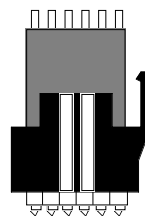

New version

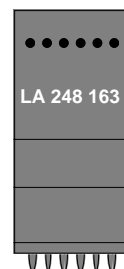

Original version

This page is deliberately left blank

SECTION 1 INSTALLATION

1.1 INSTALLATION PROCEDURE

The installation procedure is as follows:

1. Unpack the recorder (section 1.2)
2. If the recorder is to be panel mounted, fit the recorder into the panel (section 1.3)
3. Connect supply and signal wiring (sections 1.4 and 1.5)
4. Fit chart and printhead (sections 1.7 and 1.8)
5. Switch on. Configure the recorder.

1.2 UNPACKING THE RECORDER

The recorder is shipped in a special pack, designed to ensure adequate protection during transit. Should the outer box show signs of abnormal wear or damage, it should be opened immediately and the recorder examined. If there is evidence of damage, the instrument must not be operated and the local representative contacted for instructions. After the recorder has been removed from its packing, the packing should be examined to ensure that all accessories and documentation have been removed.

1.3 MECHANICAL INSTALLATION

As shown in figure 1.3 below, the recorder is intended for installation in a 281 mm x 281 mm cutout, in a panel which is either vertical or sloping up to 30 degrees. Particular attention should be paid to the recommended minimum distances between adjacent recorders. These distances are advised in order to retain ease of access, to allow full door opening and for panel strength considerations.

The instrument is inserted through the panel cutout, from the front. With the weight of the recorder supported, the panel clamps are clipped into the holes located, one each side of the recorder. The jacking screws should now be tightened until the springs of the panel jacks are compressed to approximately half of their free length.

Once the recorder is securely mounted, the door should be opened (by lifting and then turning the latch clockwise) and the internal packing removed and stored with the external packing, against future transport requirements.

1.4 SUPPLY VOLTAGE CONNECTION

All connections are made at the rear of the recorder. Supply voltage wiring, supply voltage selection and fuse replacement can all be carried out without the removal of the terminal cover.

1.4.1 Supply voltage selection

As shown in figure 1.4.1 (page 1-5), the supply voltage setting switch is located to the right of the fuse drawer associated with the IEC plug. The switch is operated upwards (230V indicated) to select 180 to 264 V, or downwards (115V indicated) to select 90 to 132V.

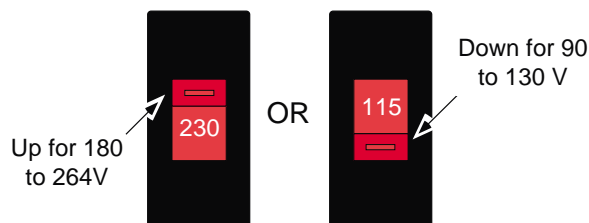

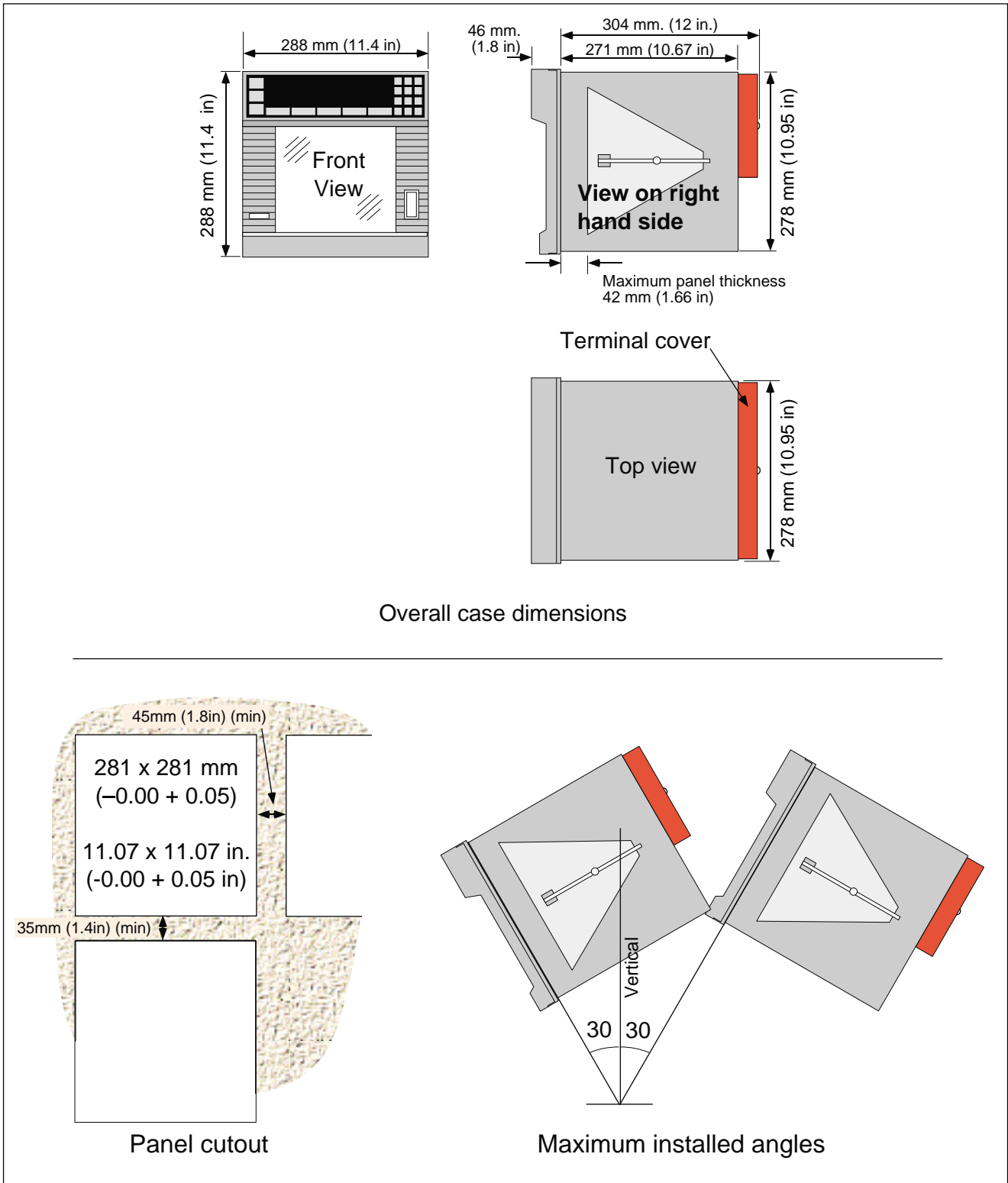

Figure 1.3 Mechanical installation

Note: If this is a graphics recorder consult the Graphics Unit Manual for special installation instructions.

1.4.2 Supply voltage wiring

Before connecting the supply to the recorder, check that the recorder voltage select switch has been set to the correct voltage range, as described above.

Before proceeding further, please read the warnings on page i - 3.

The line supply is terminated using an IEC socket which is connected into the mating plug at the rear of the recorder power supply (figure 1.4.1). Recommended minimum wire size is 16/0.2 (0.5 mm²)

1.4.3 Supply voltage fuse

The supply fuse is located in a pull-out drawer integral with the IEC plug. The fuse specifications (3.15 Amp type F) are the same for both supply voltage ranges, and are as follows:-

Rating	3.15 Amps
Size	20 mm
Speed	Fast blow
Material	Ceramic

It should be ensured that only fuses with the required rated current and of the specified type are used for replacement. The use of makeshift fuses, and the short-circuiting of fuse holders are prohibited, and will invalidate the manufacturer's warranty.

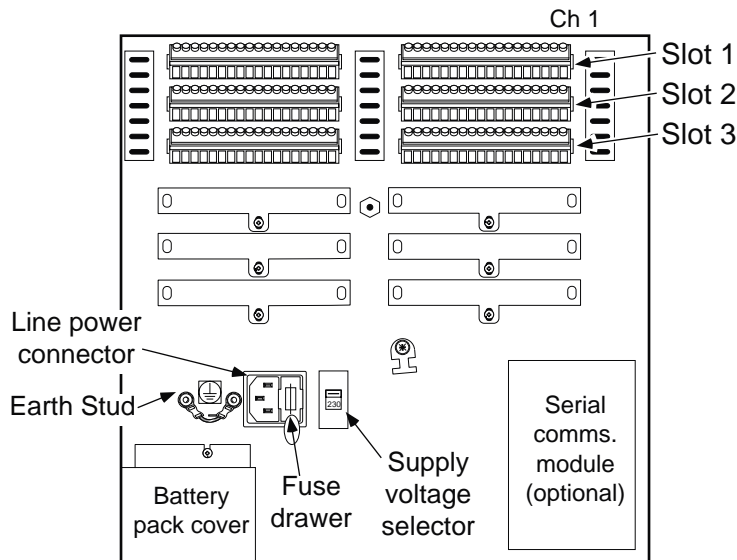

Figure 1.4.1 Recorder rear view with terminal cover removed

1.5 SIGNAL WIRING

All signal wiring terminations are located behind the terminal cover (figure 1.3). This acts not only as protection, but also as a thermal 'container' to reduce temperature fluctuations as much as possible for the thermocouple cold junction terminations. To remove the rear cover, release the screw securing it to the rear of the recorder. Slot 1 is the topmost slot, and channel 1 is the right-most channel.

Figure 1.5 shows signal wiring for the various inputs supported by the recorder.

Note: Recommended maximum wire size is 2.5 mm²

1.5.1 The analogue output board as a transmitter power supply

Each analogue output channel can be wired to provide 24V at up to 25mA as shown in figure 1.5.1 below. Typical configuration pages are as follows:

Analogue output channel

The analogue output channel should be set up as follows (see section 4 for details):

O/P Type mA	4.00 to 24.00	
Source	Constant 24.000	Enabled





Value Format	XXX.XX	
On error	Drive hi	

To find the channel number, the 'CARDS' section of the 'INSTRUMENT' configuration should be accessed, to find the address of the analogue output board. Each address is associated with 8 channels, so an address of two, for example, means that the first analogue output channel is 9.

Analogue input channel

I/P Type mA	4.00 to 20.00	
Shunt	100.00 ohms	



Lin Func.	Linear	
	Unscaled	



Value format	XXX.XX	
Damping	None	

(Continued)

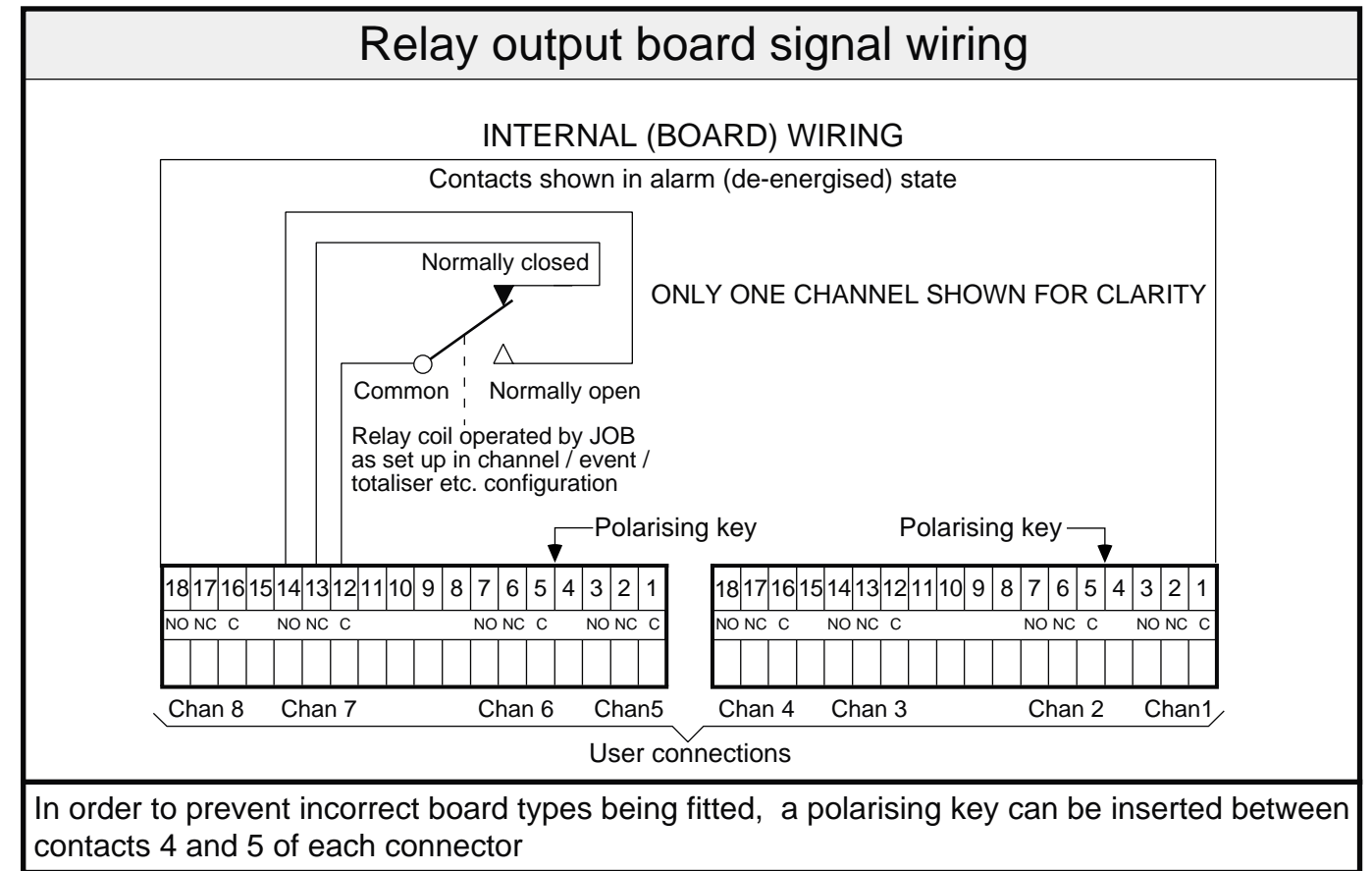
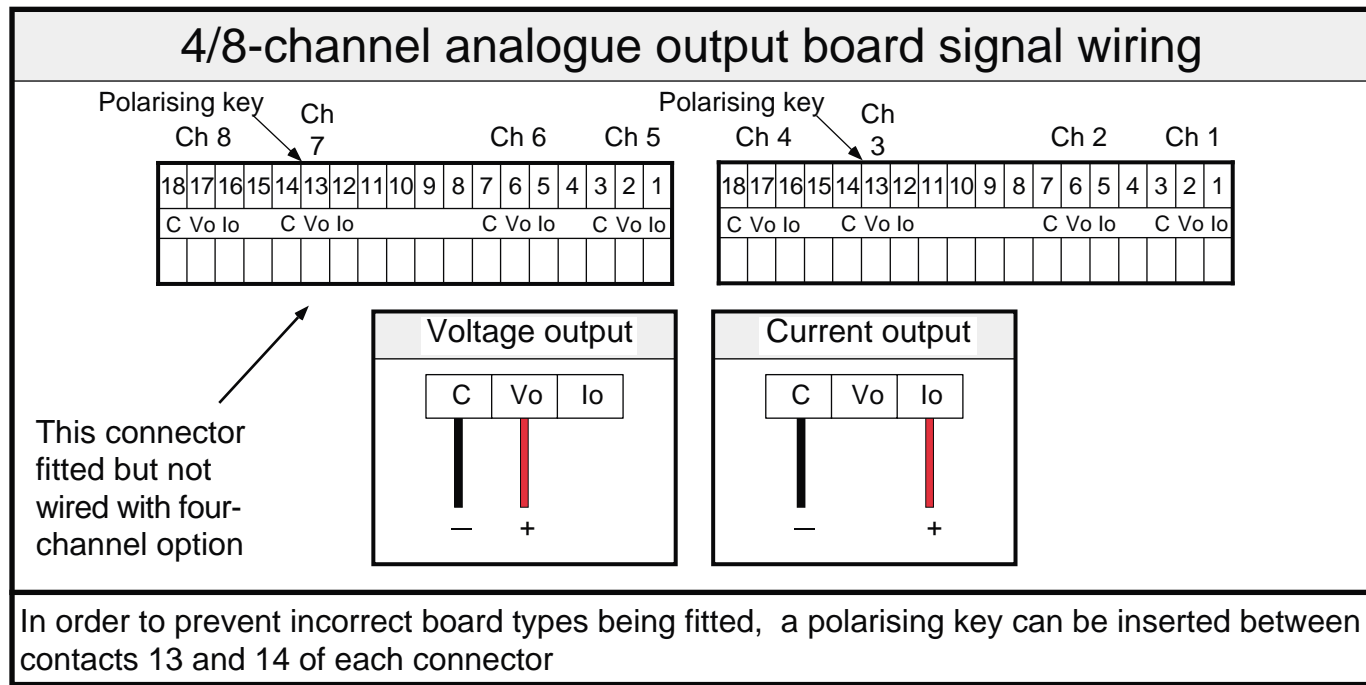
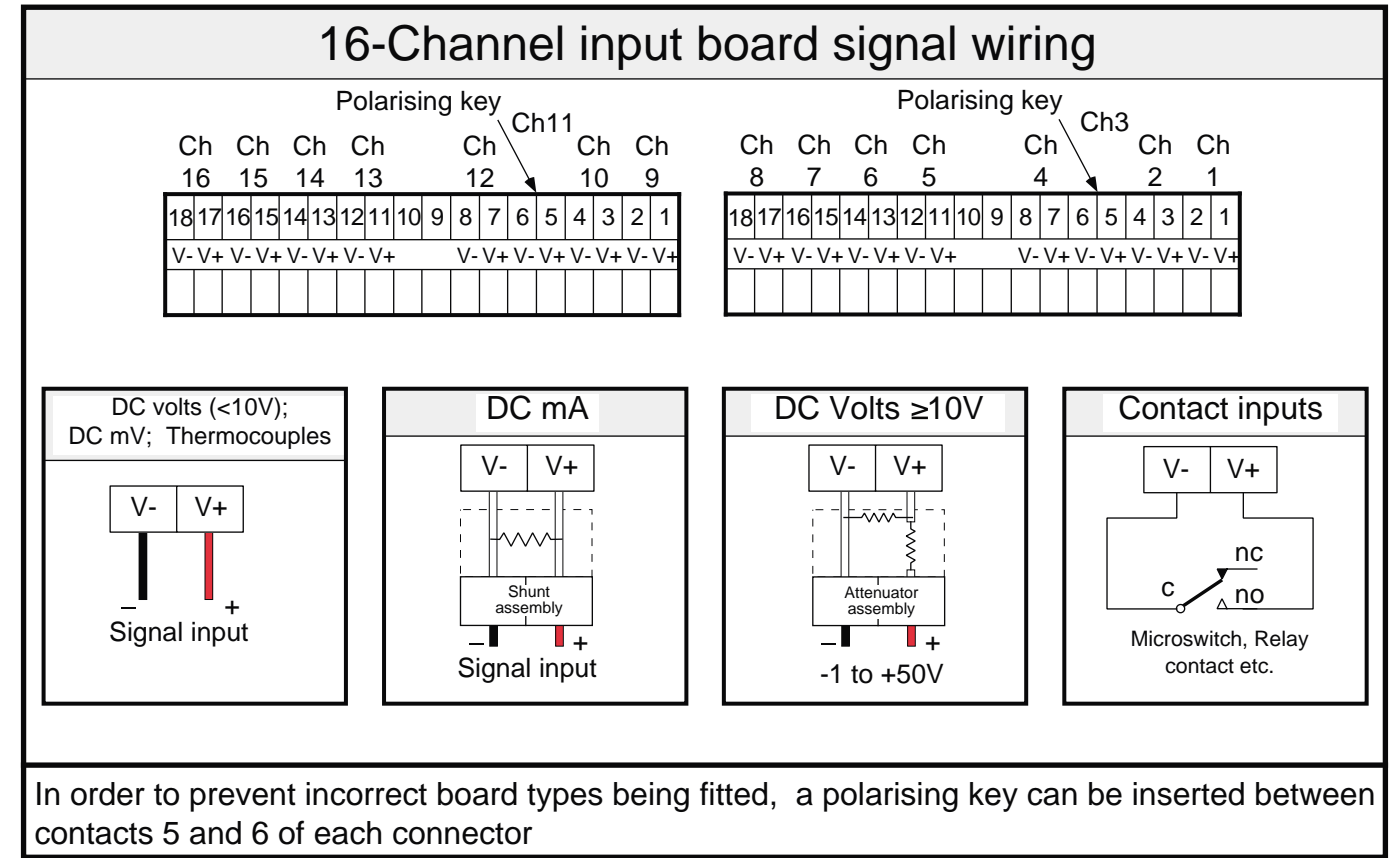
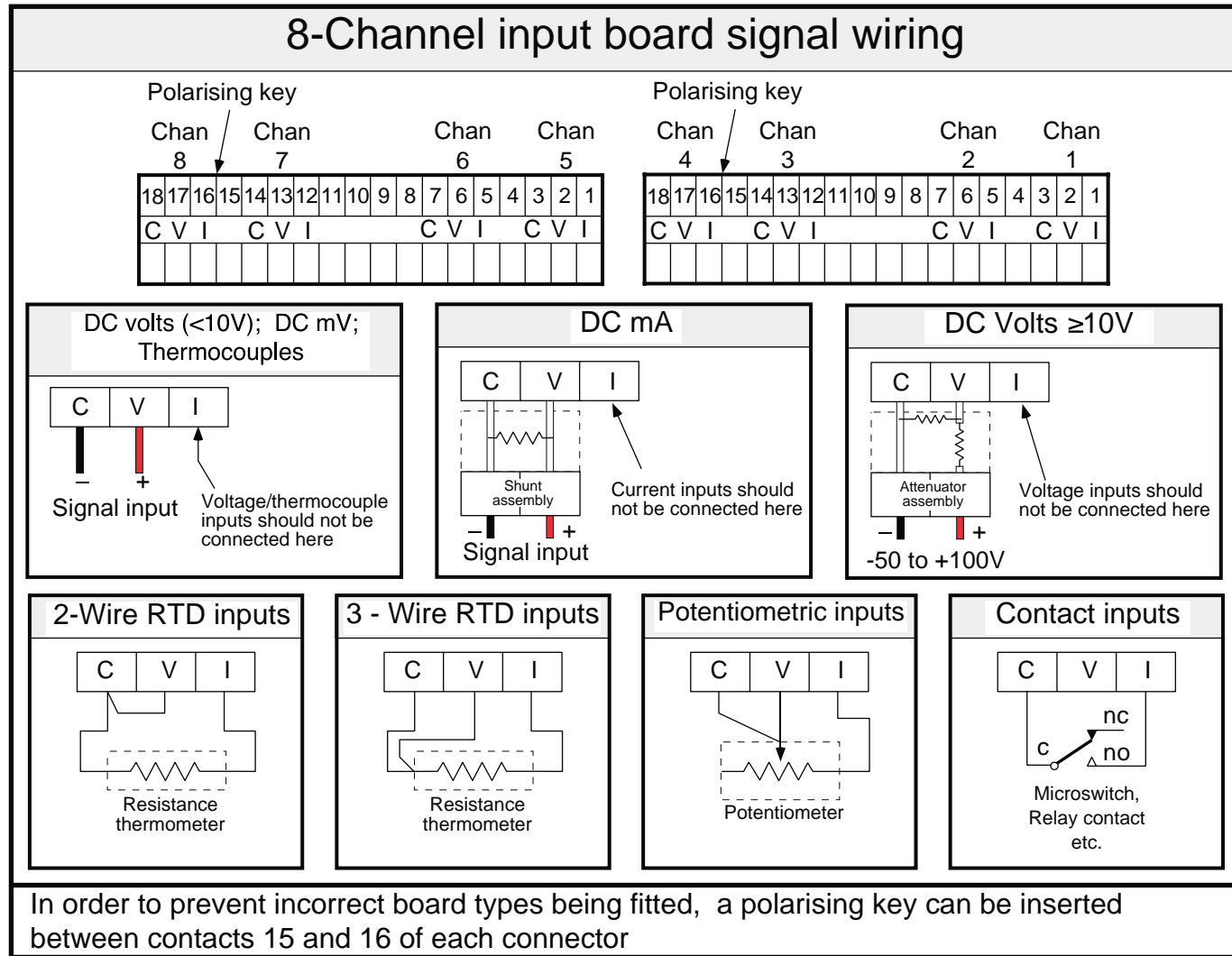

Figure 1.5 Sheet 1
Signal wiring - terminations

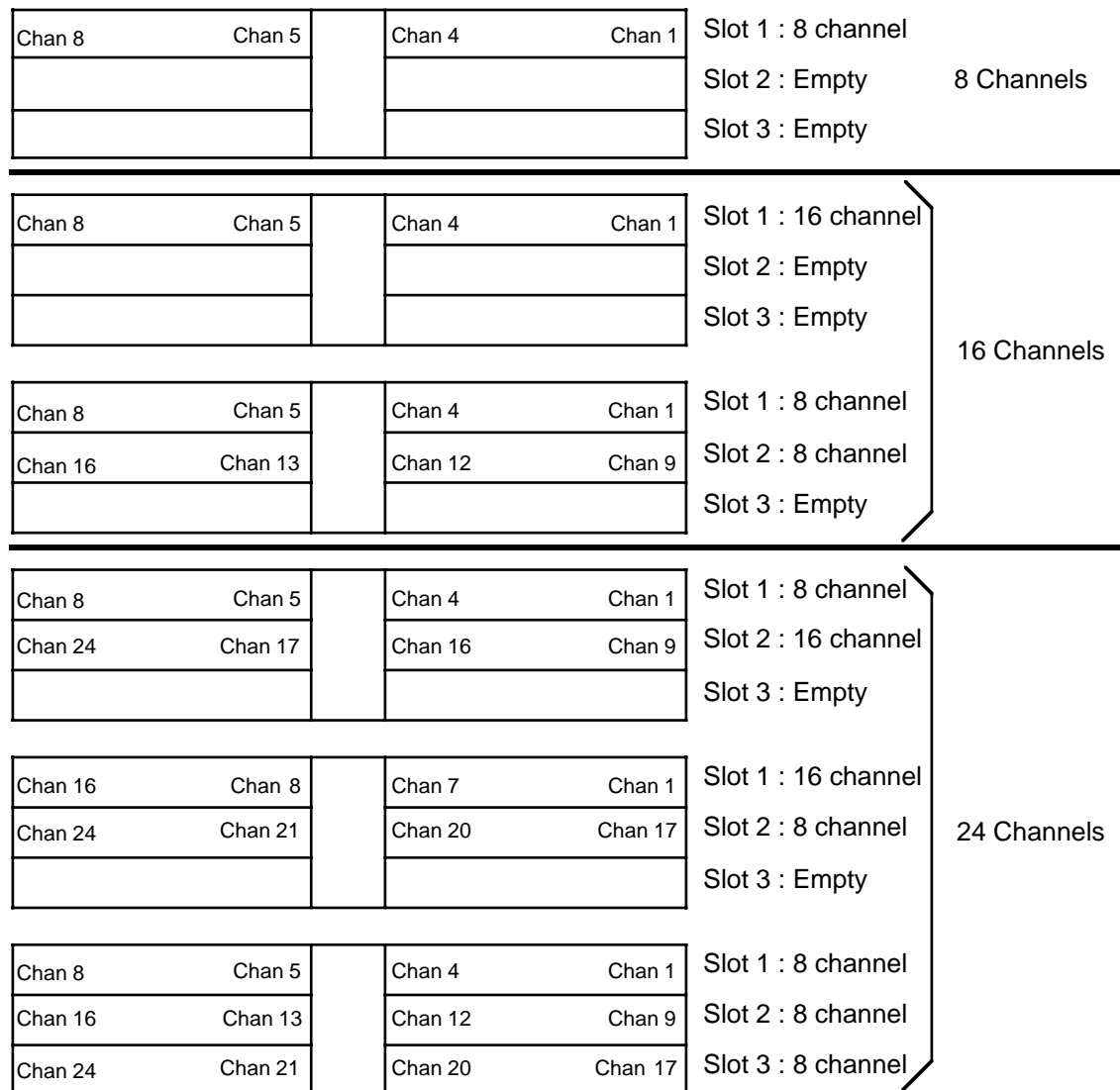

Figure 1.5 Sheet 2
Signal wiring - Channel locations

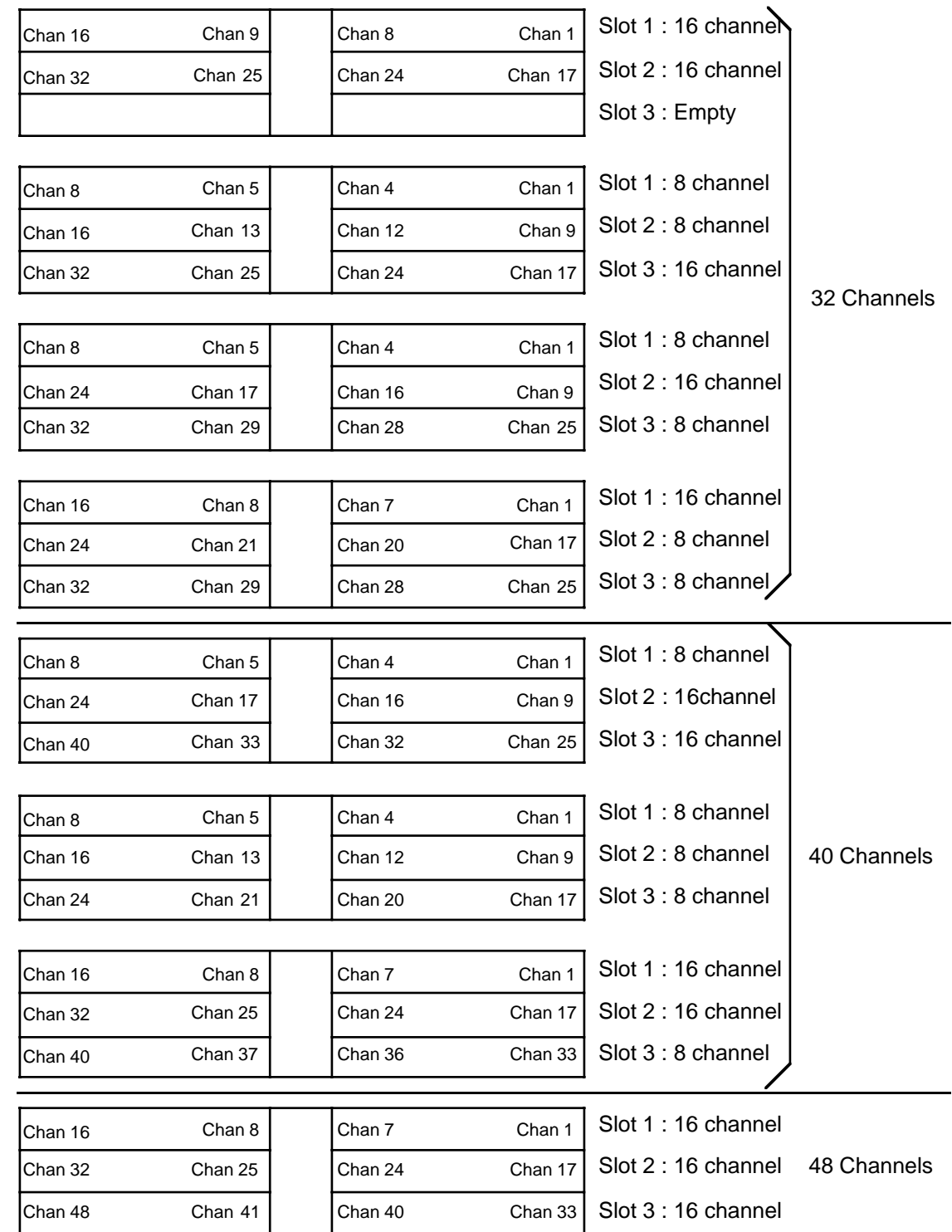

Figure 1.5 Sheet 2
Signal wiring - Channel locations

1.5.1 TRANSMITTER POWER SUPPLY (Cont.)

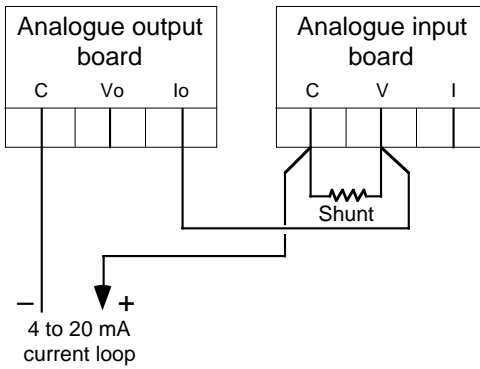

Figure 1.5.1 Wiring of the analogue output as a Transmitter Power Supply

1.6 CONFIGURATION TRANSFER WIRING

As explained in section 4.10, the configuration of one recorder can be transferred to or from one or more other recorders using the 9-way D-type socket located inside the recorder, on the right-hand side, above the chart cassette. Figure 1.6a shows the cable specification for a connection between two recorders. No screen is necessary.

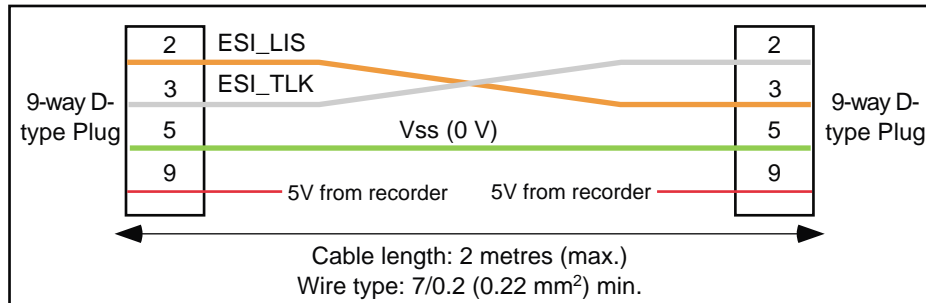

Figure 1.6a Cable specification for configuration transfer

Configuration transfer can also be carried out between the recorder and any host computer or configuration terminal which is capable of accepting 5 V logic levels at its RS232 input, and which does not require hardware handshake. An RS232 converter may be required with some computers to change the recorder's signals to 12 V.

Figure 1.6b shows how to wire the recorder link to host computer 9-way and 25-way D-types. It is up to the user to determine whether a plug or socket is required at the host computer end of the link.

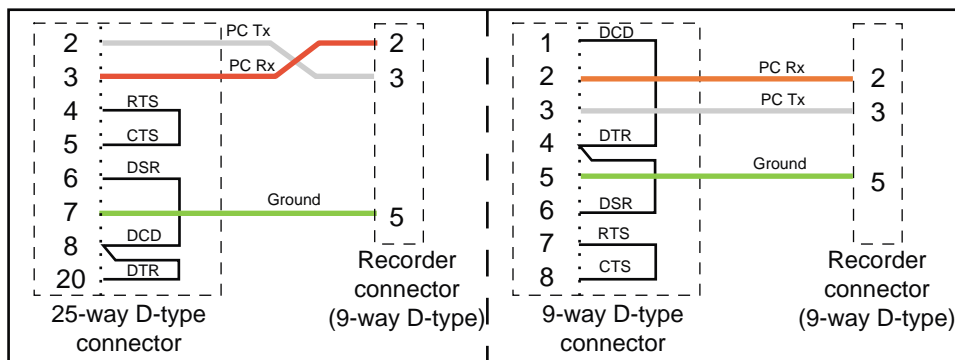

Figure 1.6b Configuration transfer port to host computer wiring

Alternatively, the communications option can be used. This allows not only configuration save and restore, but also full configuration and monitoring functions.

A PC configuration tool is available from the manufacturer.

1.7 CHART INSTALLATION / REPLACEMENT

Note: See Annex B for previous recorder versions

Before fitting a chart, the chart drive must be switched off, as follows:

- Operate the 'Home' hard key.
- Operate the 'CHART' softkey.
- Operate the ON/OFF softkey, then the OFF or FAST OFF softkey.
- When 'Printer is off line' appears, operate the PARK softkey and wait until the print cartridge parks somewhat to the right of centre.
- Note the position of the ADVANCE softkey.

```
1 123.4 Deg C Ch1 Tag
2 LINE MODE HOLD NEXT PREVIOUS
```



```
Operator select a category
DISPLAY CHART ALARM CHANNEL MORE>
```



```
Chart : select a category
ON/OFF SPEED LOG INT MODE SCALES
```



```
Printer is on line
OFF FAST OFF
```



```
Printer is off line
ON PARK ADVANCE
```



1.7.1 Old chart removal

Open the door of the recorder by lifting the latch and rotating it clockwise. If fitting a chart for the first time, or if the previous chart has already been removed, go to section 1.7.2.

Pull the paper guide forwards, as shown (A), and disengage the remaining chart (B) from the drive sprockets. Pull the end of the chart downwards clear of the platen.

Open the lower paper tray by rotating it forwards as shown (C) in the figure, and remove the old chart.

Remove any residual paper dust from the paper tray.

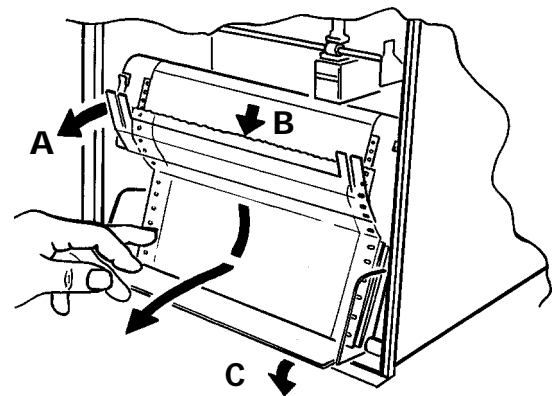

Figure 1.7.1 Chart removal

1.7.2 Fitting a new chart

Release the platen by pushing upwards on one or both latches (D). Swing the platen forwards to reveal the upper paper tray. Remove any residual paper dust.

Check that the printhead guide bars are clean and shiny and that the drive belt and flexi cable for the printhead are in good condition. If not, carry out remedial action as described in the Service Manual.

Remove the new chart from its packing and fan (as shown in figure 1.7.2a) several times to separate the leaves, and to remove loose paper dust. Ensure that the leaves are fully separated, or the paper transport will not operate correctly.

Orient the chart such that the red end-of-chart line is at the bottom, and the circular chart holes are to the left (i.e. the elongated slots are to the right). Load the chart into the upper paper tray and unfold the top three or four leaves.

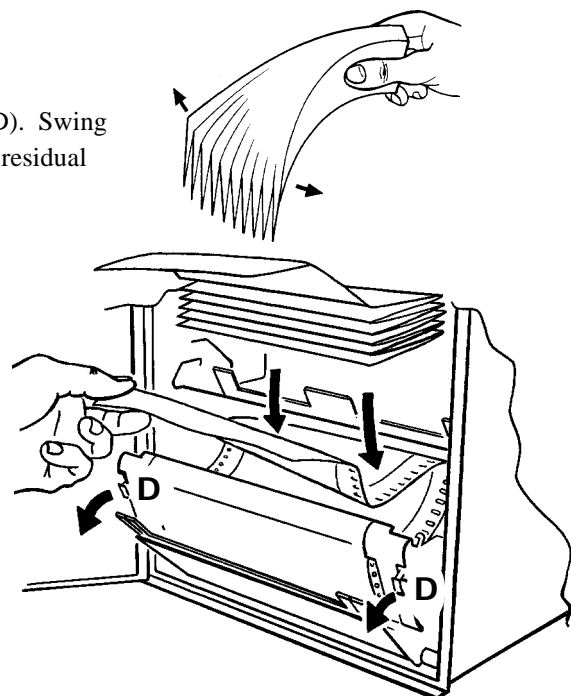

Figure 1.7.2a Loading the new chart

1.7.2 FITTING A NEW CHART (Cont.)

As shown in figure 1.7.2b, feed the top few leaves between the paper guide and the platen, then push the platen closed **ENSURING THAT IT LATCHES CORRECTLY INTO PLACE**.

With the paper guide pulled forwards, feed the end of the chart through the gap between the platen and the paper guide, and lay the first two or three leaves in the bottom (take-up) paper tray.. Close the paper guide, ensuring that both sets of chart holes locate correctly on the drive sprockets, and that the horizontal grid lines are parallel with the chart guide.

If the chart is loaded correctly, the circular holes will be on the left, and the printed grid will be uppermost, with no red line showing.

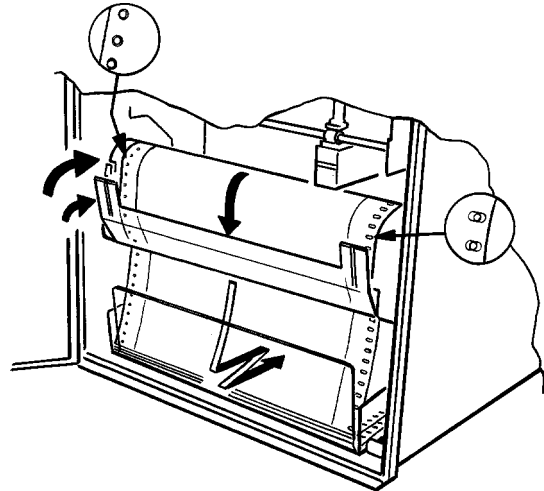

Figure 1.7.2b Chart loading

Ensure that the paper lies naturally (i.e. the fold direction is the same as when packed by the chart manufacturer), then use the ADVANCE softkey to feed more chart through, to ensure it is moving smoothly.

FAILURE TO ENSURE THAT THE CHART FOLDS NATURALLY WILL RESULT IN THE EVENTUAL MALFUNCTIONING OF THE CHART FEED.

1.8 PRINT CARTRIDGE REPLACEMENT

Caution

Before attempting to change the print cartridge it is essential to ensure that the printhead/cartridge is parked, as described in section 1.7, above, otherwise it will not be possible to change the cartridge without risk of damage.

Note:

- 1 To ensure maximum printhead life, it is recommended that the print cartridge be removed and stored separately, in a sealed container, if the recorder is to be left unpowered for an extended period.
- 2 See Annex B for previous recorder versions.
3. In order to avoid getting ink marks on the hands, it is recommended that a pair of disposable gloves be used when handling the print cartridge.

Switch the printer off-line and park the printhead as described in section 1.7 above.

Open the platen by pushing upwards on one or both latches. Carefully pull the printhead downwards as shown in figure 1.8, to remove it.

Unpack the new print cartridge and push it upwards into the carriage, ensuring that it is pushed fully home, close the platen and return the recorder to service.

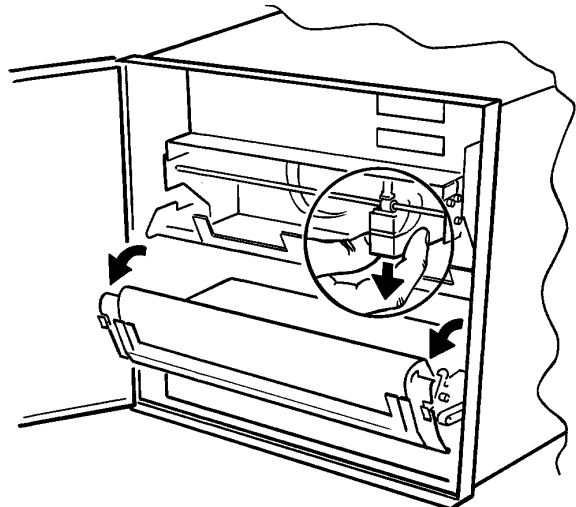

Figure 1.8 Print cartridge replacement

This page is deliberately left blank

SECTION 2: BASIC OPERATION

LIST OF CONTENTS

Section	Page
2.1 FIRST SWITCH ON	2 - 2
2.2 OPERATOR INTERFACE	2 - 3
2.2.1 Display control hardkeys	2 - 3
HOME KEY	2 - 3
ENTER KEY	2 - 3
CANCEL KEY	2 - 3
2.2.2 Status indicators	2 - 4
2.2.3 Text editing	2 - 4
NORMAL CHARACTER SET	2 - 4
ALTERNATIVE CHARACTER SET	2 - 4
2.3 CONFIGURATION EXAMPLE	2 - 7
2.3.1 Required channel inputs / outputs	2 - 7
2.3.2 Accessing configuration	2 - 7
2.3.3 Chart speed	2 - 8
2.3.4 Channel range	2 - 8
INPUT TYPE, RANGE ETC.	2 - 8
LINEARISATION TYPE AND SCALING	2 - 9
DISPLAY FORMAT, DAMPING AND BREAK	2 - 9
RESPONSE	2 - 9
2.3.5 Channel alarms	2 - 10
ALARM TYPE AND SETPOINT	2 - 10
ALARM ACTIONS	2 - 10
2.3.6 Channel zone	2 - 11
SETTING THE CHART AREA FOR TRACING	2 - 11
CHART SCALE	2 - 11
2.3.7 Channel trace	2 - 12
TRACE ON/OFF; TRACE COLOUR	2 - 12
2.3.8 Channel identification	2 - 12
SETTING TRACE IDENTIFIERS	2 - 12
2.3.9 Group configuration	2 - 13
SELECTING THE GROUP	2 - 13
DEFINING THE GROUP CONTENTS	2 - 13
GROUP FORMAT	2 - 13
2.3.10 Selecting the group for display	2 - 14
2.3.11 Printing the configuration on the chart	2 - 14
2.4 COPY CONFIGURATION	2 - 16
2.4.1 Copy range and zone	2 - 16
2.4.2 Trace colour	2 - 17
2.4.3 Trace Identifiers	2 - 17

2: BASIC OPERATION

This section is designed to help you as a new user to configure a channel to a set of basic parameters so you can start recording your own traces with the minimum of effort.

For full information about Operator and Configuration displays see sections 3 and 4/5 respectively.

Figure 2.3 is a type of map to help show you round the top level menus of the recorder. The diagram shows all available options. If an option isn't fitted then its softkey doesn't appear, so your displays might be slightly different from those shown.

2.1 FIRST SWITCH ON

To apply power to the recorder, open the recorder door, release the platen by pushing upward on the catches. With the platen open, the power on-off switch can be located as shown in figure 2.1.

When the recorder is switched on, an initialisation message appears briefly at the display, and a 'Power on' message is printed on the chart. The message includes the current time and date, the print mode (trace priority) and chart speed (120mm / hr).

After initialisation is complete, the display goes into 'background mode' i.e. it displays a single channel's number, status or value and 'tag' on the top line, and will have a series of 'softkey' legends on the lower line.

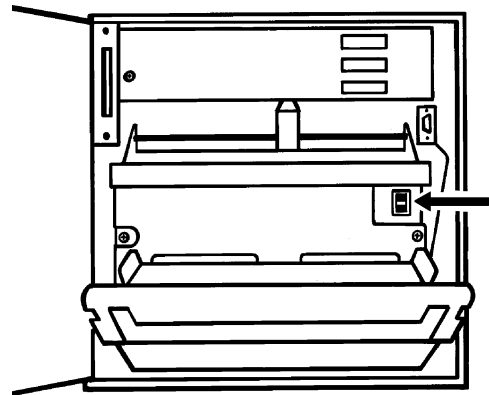

Figure 2.1 On-off switch location

01	OFF	1				
2	LINE	MODE	HOLD	NEXT	PREVIOUS	← Softkey legends

The softkeys (2 LINE, MODE etc.) are fully described in section 3.

The first channel to be displayed is the first channel fitted (normally 1).

After approximately 3 seconds, the display changes to show channel 2 and so on until all the measuring channels have appeared. After all the measuring channels have been 'scrolled through' in this way, any option values (maths channels, totalisers/counters) are displayed in turn, before channel 1 is returned to.

As delivered, all channels are set to OFF. In order to carry out measurements and start tracing, you need to tell the recorder what input types are wired to each channel, what ranges and scales to use, alarm setpoints, alarm types and so on.

To do this, you need to access the configuration menus, but before you do, here is some basic information you need to do the job.:

2.2 OPERATOR INTERFACE

The 'Operator interface' is the name given to the display and its associated hardkeys (including numeric keys) and softkeys.

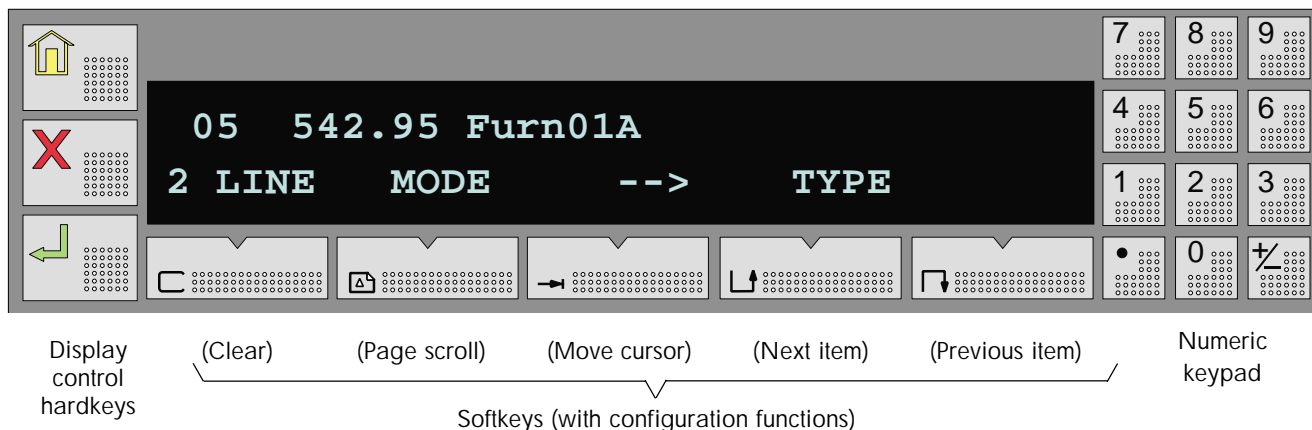

Figure 2.2 Display / keyboard

2.2.1 Display control hardkeys

These three keys, located to the left of the display, help you to access and edit items with minimum effort.

HOME KEY

The 'HOME' key is used one or more times to return you to the top level menus as follows:

- If the display is in background mode, a single operation of this key will call the top level operator menu.
- If you are in the operator menus operation of the 'HOME' key will return you to the top level operator menu.
- During configuration, a single operation of the key will return to the top level configuration menu, a second operation will return you to the operator top level menu.

ENTER KEY

The 'Enter' key is used to confirm any changes to operation or configuration made since the last time it was operated. If no such changes have been made, the key moves you up one menu level

CANCEL KEY

The cancel key is used to 'undo' any changes made since the Enter key was last operated. If no such changes have been made, the key moves you up one menu level.

2.2.2 Status indicators

During normal operation of the recorder (i.e. not in configuration), characters 39 and 40 of the top line of the display are used to indicate recorder / input status as follows.

- # Channel alarm. This bell symbol flashes whenever an unacknowledged active alarm is present. The bell is steadily illuminated if an acknowledged alarm is present but again flashes if a further unacknowledged alarm becomes active. See section 3.2.3 for how to acknowledge alarms.
- P Printer off indicator. This appears if the printer drive has been switched off.
- I System error indicator The System error indicator appears if any of the items listed below is true. Any current system errors can be viewed via the Operator menu (Section 3) or instrument configuration pages (section 4.2)
 1. There is a fault with remote CJ temperature.
 2. The battery is exhausted or missing.
 3. There is a failure in the real-time clock or the time/date have not been set.
 4. There is a fault in the writing system.
 5. There is a fault in an input or derived channel.
 6. Battery-backed RAM failure or EEPROM failure.
 7. Memory card battery low or exhausted.

2.2.3 Text editing

Text entry is by means of the cursor and up and down scroll keys together with the  key.

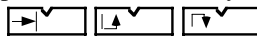

The cursor (right arrow) key is used to locate the cursor beneath the character to be edited and the scroll keys are then used to scroll through either of the character sets depicted (approximately) below.

Notes:

1. The two sets can be switched between using the key associated with the numeric keyboard.
2. The clear key  can be used to clear the text string from the cursor position to the end inclusive.
3. Should an error be made, the cancel key can be used to 'undo' all changes so far made to the text string.
4. Under certain circumstances, it is possible to have the current time, date etc. included in a message to be printed in the chart. See the 'Embedded Sequences' description in section 3.3.3.

Normal character set

A to Z, a to z, Ä ä à ç ê è é Ö ö ô Û ü ù ß Σ μ Ω δ (space) # \$ % & () * + , - . / : ; < = > _ £ ° 0 to 9, (Space)

Alternative character set

^{2 3} ! “ ” [\] ^ ° { | } ~ Ç â å ë ì ï Å É æ Æ ò û ÿ ç ¥ á í ó ú ñ Ñ ù ò ì ; « » α Γ π σ τ φ θ ∞ ∈
 ∩ ≡ ± ≥ ≤ ÷ ≈ • √ η •

For full details of operator and configuration menus, see sections 3 and 4 respectively

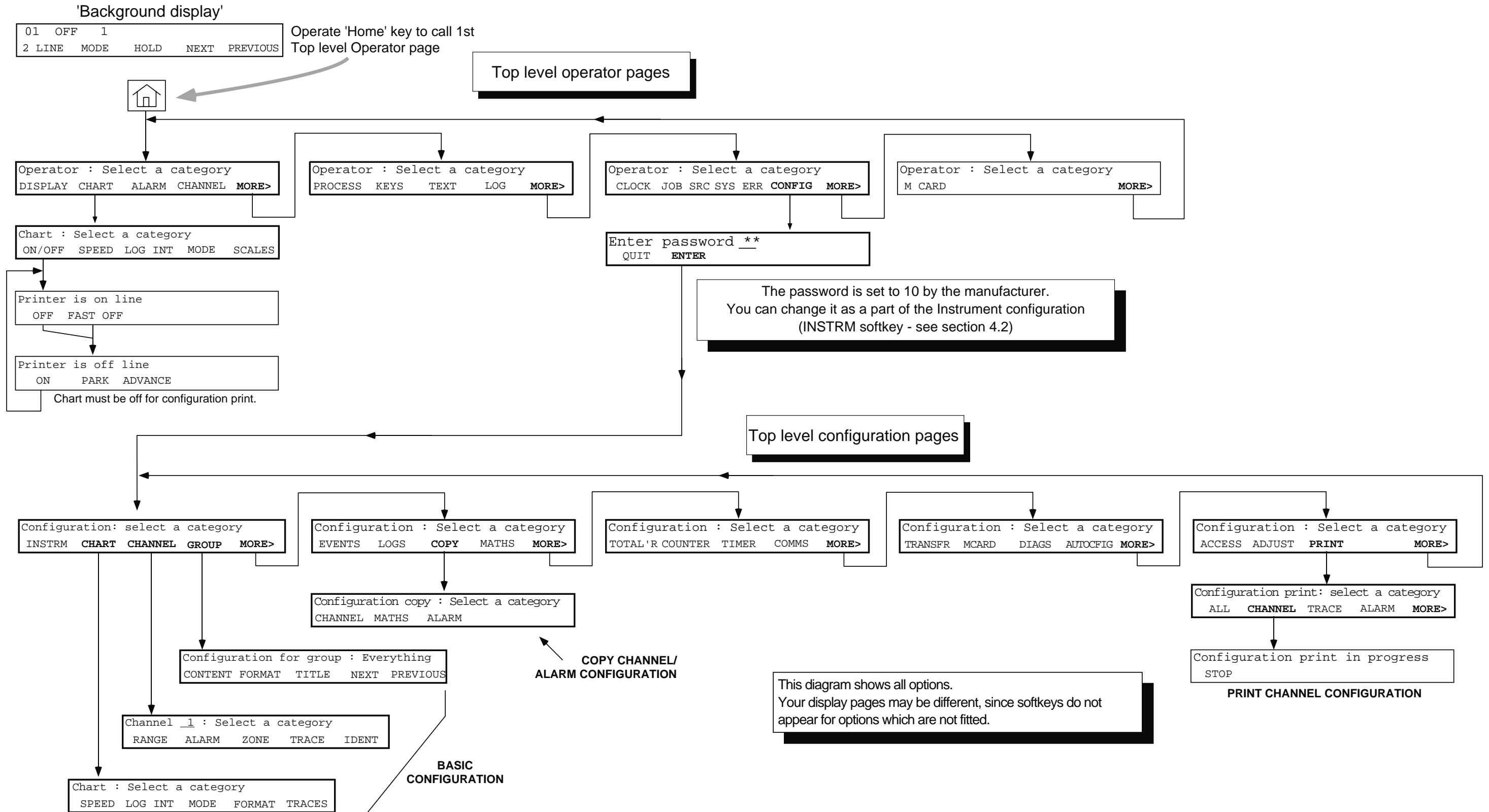

Figure 2.3 Basic menu structure

This page is deliberately left blank

2.3 CONFIGURATION EXAMPLE

This section gives you a step-by-step guide showing you how to set up (configure) a single channel to accept a particular type of input signal and the range of temperatures to be measured; to set up the chart range, to enter a name for the channel; and to select an alarm type and threshold. This is sufficient to get you going, but further sections are included to help you to copy your configuration to one or more further channels, how to set up a group for display, and how to print your set-up on the chart.

2.3.1 Required channel inputs / outputs

Before you start to configure any channel you will need to know exactly what you want the recorder to do with the input you are providing. It is recommended that, for each channel, you have a list of parameters which are to be set up similar to the following imaginary example:

Channel Number	5
Temperature range	0 to 900 °C
Display scale	0.00 to 900.0 °C
Input type	Type K thermocouple, using the recorder's internal cold junction for compensation.
Chart span	400 to 800 °C
Chart scale	10 divisions
Input Break response	Upscale Drive.
Trace	Enabled; black; interpolation on.
Descriptor	Furnace No1 temp A
Tag	Furn01A
Alarm	Tripped immediately if the temperature exceeds 780°C, and remains tripped until acknowledged. Sounds internal buzzer whilst active.

The channel is to be displayed as a member of a group called 'Furnace 1 temps' which includes channels 5 to 8, and it is to be traced with the recorder chart speed set to 60 mm/hr.

2.3.2 Accessing configuration

If the recorder is switched off, open the recorder door, and operate the power on-off switch located behind the chart cassette.

The recorder will initialise itself. This means that it gets data from the various areas of memory, and sets up the trace/display etc. functions previously configured. If no previous configuration has taken place (as assumed below) then the 'default' values (i.e. values entered at manufacture) are used.

Once initialisation is complete, the first display page appears. The page shown opposite is the default type of display mode. Operation of the home key calls the first of the top level Operator Menu pages to the display.

```
01 OFF 1
2 LINE MODE HOLD NEXT PREVIOUS
```



Operation of the 'Softkey' immediately below the MORE> legend calls the second of the top level Operator Menu pages to the display.

```
Operator : Select a category
DISPLAY CHART ALARM CHANNEL MORE>
```



Operation of the softkey immediately below the MORE> legend calls the third of the top level Operator Menu pages to the display.

```
Operator : Select a category
PROCESS KEYS TEXT LOG MORE>
```



As you can see, CONFIG is the fourth softkey.

```
Operator : Select a category
CLOCK JOB SRC SYS ERR CONFIG MORE>
```

2.3.2 ACCESSING CONFIGURATION (Cont.)

THE RECORDER IS DESPATCHED FROM THE MANUFACTURER WITH A PASSWORD OF '10'

Operation of the softkey immediately below the CONFIG legend causes the Password entry page to appear.

Enter the password, by operating the '1', then the '0' numeric keys followed by operation of the 'Enter' key:

<1> <0>  (Enter)

```
Operator : Select a category
CLOCK JOB SRC SYS ERR CONFIG MORE>
      [v]
Enter Password *****
```

2.3.3 Chart speed

Operation of the CHART softkey calls the CHART configuration page. We are interested only in setting the chart speed, so press the SPEED softkey.

Operate the scroll down key as often as necessary to change speed A to 60 mm/hr, then press the enter key followed by the Home key to save the new speed in the recorder's memory, and then to return to the top level configuration menu.

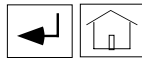

```
Configuration : Select a category
INSTRM CHART CHANNEL GROUP MORE>
      [v]
Chart : Select a category
SPEED LOG INT MODE FORMAT TRACES
      [v]
Speed A 120 mm/hr Speed B 1200 mm/hr
Units mm/hr User speed 120 mm/hr
      [v]
Speed A 60 mm/hr Speed B 1200 mm/hr
Units mm/hr User speed 120 mm/hr
```

2.3.4 Channel range

Use the CHANNEL softkey to call the top level Channel Configuration Menu to the display.

Select the required channel number (5 in this case) using the numeric keyboard. After channel five has been selected, press the RANGE softkey.

INPUT TYPE, RANGE ETC.

You can use the field scroll keys to scroll through the various input types available. (A single operation of the up key calls T/C (thermocouple) as input type.)

Note that °C and CJC type internal are default values. Alternative values are scrollable using the field scroll keys.

Use the arrow key twice to move the cursor to the second of the temperature input fields.

Enter the high input range (900) using the numeric keys.

Do not operate the enter key yet !

Use the page scroll key to call the next page.

```
Configuration : Select a category [L]
INSTRM CHART CHANNEL GROUP MORE>
      [v]
Channel 1 : Select a category
RANGE ALARM ZONE TRACE IDENT
      <5>
Channel 5 : Select a category
RANGE ALARM ZONE TRACE IDENT
      [v]
I/P Type Off [L]
      [v]
I/P Type T/C 0 to 10.00 °C [L]
CJC type Internal
      [v]
I/P Type T/C 0 to 10.00 °C [L]
CJC type Internal
      [v]
I/P Type T/C 0 to 10.00 °C [L]
CJC type Internal
      <9><0><0>
I/P Type T/C 0 to 900 °C [L]
CJC type Internal
      [v]
```

2.3.4 CHANNEL RANGE (Cont.)

LINEARISATION TYPE AND SCALING

The page scroll key calls the second channel range page to the display, where 'Linear' appears as the default.

Use the field scroll up key repeatedly to scroll through the linearisation types until 'Type K' appears.

Use the page scroll key to call the next display page:

DISPLAY FORMAT, DAMPING AND BREAK RESPONSE

The default decimal point position is two decimal places as required. Use the arrow key to move to the 'Damping' field.

The default 'Damping' value of 'None' is as required.

Use the arrow key to move the cursor to the 'I/P break response' field. Use the field scroll up key, to change from None to 'Drive hi'.

Operate the Enter key once to confirm all the changes so far, then again to return to the top level Channel Configuration menu.



```
Lin Func Linear
Unscaled
```

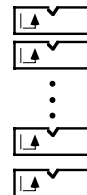

```
Lin Func Type K
Unscaled
```



```
Value format XXX.XX
Damping None I/P break response None
```



```
Value format XXX.XX
Damping None I/P break response None
```



```
Value format XXX.XX
Damping None I/P break response None
```



```
Value format XXX.XX
Damping None I/P break response Drive hi
```

2.3.5 Channel alarms

ALARM TYPE AND SETPOINT

Use the alarm softkey to call the alarm setpoint / jobs page to the display. The default alarm number is 1, which will be used here for convenience. (The numeric keys would be used to select alarms 2 to 4 for this channel). Use the SET PT softkey to access the setpoint configuration page.

Use the field scroll down key twice to scroll the alarm enable field from 'Off' through 'Trigger' to 'Latched'.

The alarm type is as required, so use the right arrow key twice to move the cursor to the Setpoint field.

Use the numeric keys to enter the value of 780.

Use the page key to call the next alarm page. Hysteresis and dwell defaults are as required. (If it had been necessary, numeric entry keys would have been used to enter a hysteresis value and to change the dwell period.)

Use the enter key once to confirm the changes, then again to return to the top level alarm page.

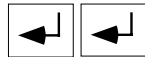

ALARM ACTIONS

Operation of the JOBS softkey calls the Alarm Jobs page. The default job number is 1, which we will use for convenience. You would use the Page scroll key to select job 2 if required.

Use the field scroll up key to scroll through the job categories: Chart, Trace, Alarm.

Use the right arrow key to move the cursor to the action field, followed by a single operation of the field scroll down key to 'Sound Buzzer'. 'While active' is the required job qualifier and this completes the alarm configuration.

Operate the enter key once to confirm the changes, again, to return to the top level alarm page, and a third time to return to the top level channel configuration page.



Channel	<u>5</u>	: Select a category
RANGE	ALARM	ZONE TRACE IDENT



Alarm	<u>1</u>	: Select a category
SET PT	JOBS	



Enable	<u>Off</u>	Type	Absolute high
Set Point	<u>10.00</u>		°C



Enable	Latched	Type	Absolute high
Set Point	<u>10.00</u>		°C



Enable	<u>Latched</u>	Type	<u>Absolute high</u>
Set Point	<u>10.00</u>		°C



Enable	<u>Latched</u>	Type	Absolute high
Set Point	<u>10.00</u>		°C

<7><8><0>

Enable	<u>Latched</u>	Type	Absolute high
Set Point	<u>780</u>		°C



Hysteresis	<u>00000</u>	°C
Dwell	<u>0s</u>	

Alarm	<u>1</u>	: Select a category
SET PT	JOBS	



J1	<u>No action</u>
----	------------------



J1	Alarm	Acknowledge alarms of
	Everything	On going active



J1	<u>Alarm</u>	<u>Acknowledge alarms of</u>
	Everything	<u>On going active</u>



J1	<u>Alarm</u>	Sound Buzzer
		While active

2.3.6 Channel zone

SETTING THE CHART AREA FOR TRACING

Use the ZONE softkey to call the first Channel Zone page. This, together with the following page allows you to enter values for Chart Span, Chart Zone and Chart Divisions.

Use the field scroll key to change 'Unspanned' to 'Chart span'.

Use the right arrow key and numeric keys to enter the chart range (span) of 400 to 800 °C

The default chart zone (full width of chart) is acceptable, so operate the page up key to call the chart scale (number of divisions) page.

CHART SCALE

Operate the field scroll up key to select 'Automatic.'

Use the right arrow key once, then the numeric keys <1> <0>, to change the number of divisions from the default (5) to 10 (as required).

This completes the channel zone configuration.

Operate the enter key twice to return to the top level Channel Configuration page.

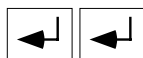

Channel 5 : Select a category
 RANGE ALARM **ZONE** TRACE IDENT



Unspanned
 Chartzone 0.0 to 100.0%



Chartspan 0.000 to 900.0 °C
 Chartzone 0.0 to 100.0%

<4> <0> <0>

Chart span 400 to 900.0 °C
 Chart zone 0.0 to 100.0%



Chart span 400 to 900.0 °C
 Chart zone 0.0 to 100.0%

<8> <0> <0>

Chart span 400 to 800 °C
 Chart zone 0.0 to 100.0%



Chart scale Off



Chart scale **Automatic** divs 5



Chart scale Automatic divs 5

<1> <0>

Chart scale Automatic divs 10

2.3.7 Channel trace

TRACE ON/OFF; TRACE COLOUR

Use the TRACE softkey to call the trace definition page.

Default conditions are as required except for Colour A which is required to be black.

Use the right arrow key to move the cursor to the 'Colour A' field.

Use the field scroll down key twice to change colour 'A' from Blue to Black.

Use the enter key twice to return to the top level Channel Configuration page.

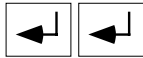

```
Channel 5 : Select a category
RANGE  ALARM  ZONE  TRACE  IDENT
```



```
Trace On           Line thickening Off
Colour A Blue      B Blue
```



```
Trace On           Line thickening Off
Colour A Blue      B Blue
```



```
Trace On           Line thickening Off
Colour A Blue      B Blue
```



```
Trace On           Line thickening Off
Colour A Black     B Blue
```

2.3.8 Channel identification

SETTING TRACE IDENTIFIERS

Use the IDENT softkey to call the first channel descriptor / tag page.

Use the Clear key to clear the default descriptor.

Use the +/- key to select the required character set, then use the up and down arrow keys and the cursor key to enter the required channel name (descriptor).

Use the page key to call the Channel Tag page, and enter the new string (Furn01A) in a similar way to that described above for the descriptor.

Operate the Enter key to confirm the changes, then the Home key to return to the top level configuration page.

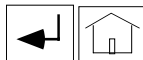

```
Channel 5 : Select a category
RANGE  ALARM  ZONE  TRACE  IDENT
```



```
Descriptor Channel Number 5
```



```
Descriptor
```



```
Descriptor Furnace No1 temp A
```



```
Tag 5
```

```
Tag Furn01A
```

```
Configuration : Select a category
INSTRM  CHART  CHANNEL  GROUP  MORE>
```

This concludes the channel configuration as defined at section 2.3.1, and should be sufficient for you to start recording using your own input signals and ranges etc. The rest of section 2.3 describes how to include channel 5 in a group called 'Furnace 1 temps' and how to select that group for display. We will then print the configuration on the chart.

2.3.9 Group configuration

SELECTING THE GROUP

Use the GROUP softkey to call the top level Group Configuration page to the display.

Use the field scroll up key to scroll to the first empty group.

Use the TITLE softkey then enter the new name (Furnace 1 temps) as described for channel ident above.

A double operation of the Enter key confirms the changes, and re-calls the top level Group Configuration Page.

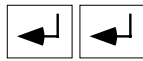

```
Configuration : Select a category
INSTRM  CHART  CHANNEL  GROUP  MORE>
      [V]
```

```
Config for Group: Everything
CONTENT  FORMAT  TITLE
      [L V]
```

```
Config for Group: Empty 1
CONTENT  FORMAT  TITLE
      [V]
```

```
Group Title is Furnace 1 temps
```

DEFINING THE GROUP CONTENTS

Operation of the CONTENT softkey calls the content page.

Use the ADD and TO softkeys and numeric entry keys to enter channels 5 to 8.

Operate the Enter key twice to confirm the changes and to return to the top level Group Configuration page.

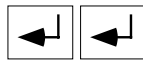

```
Config for Group: Furnace 1 temps
CONTENT  FORMAT  TITLE  NEXT  PREVIOUS
      [V]
```

```
-->
CLEAR  TYPE ↑  -->  ADD  TO
      [V]
```

```
--> 01,
CLEAR  TYPE ↑  -->  ADD  TO
      <5>
```

```
--> 05,
CLEAR  TYPE ↑  -->  ADD  TO
      [V]
```

```
--> 05- 01,
CLEAR  TYPE ↑  -->  ADD  TO
      <8>
```

```
--> 05- 08,
CLEAR  TYPE ↑  -->  ADD  TO
```

GROUP FORMAT

Operation of the format softkey allows the Engineering units to be defined as being included or not included, according to the yes/no field (field scroll key).

This key also allows the format of channels in the specified group to be defined as 'Number/tag', 'Number only' or 'Number/Descriptor' using the field scroll keys.

In this case, the defaults are acceptable, and the group configuration is completed by an operation of the Enter key.



This is followed by two operations of the Home key to cause a return to the Operator Top Level Menu.

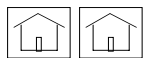

```
Config for Group: Furnace 1 temps
CONTENT  FORMAT  TITLE  NEXT  PREVIOUS
      [V]
```

```
Include item units yes
Item identification by Number/Tag
```

```
Configuration : Select a category
INSTRM  CHART  CHANNEL  GROUP  MORE>
```

```
Operator : Select a category
DISPLAY  CHART  ALARM  CHANNEL  MORE>
```

2.3.10 Selecting the group for display

Operation of the DISPLAY softkey, followed by the MODE softkey, calls the 'Group Select' page to the display.

Use the NEXT and PREVIOUS keys to scroll through the various group names, until 'Furnace 1 temps' appears.

Operation of the Enter key now completes the configuration defined in Section 2.3.1



The displayed value (probably >Range) will be meaningless since the example set-up just completed will not match the actual input conditions of your own recorder. Remain in Operator Mode for the time being.

```
Operator : Select a category
DISPLAY  CHART  ALARM  CHANNEL  MORE>
```



```
01 23.57 Deg C   Pond Temperature
2 LINE  MODE    HOLD  NEXT  PREVIOUS
```



```
Gp Everything          Mode Numeric
-->                   NEXT  PREVIOUS
```



```
Gp Furnace 1 temps    Mode Numeric
-->                   NEXT  PREVIOUS
```

```
05  >RANGE °C     Furn01A
2 LINE  MODE    HOLD  NEXT  PREVIOUS
```

2.3.11 Printing the configuration on the chart

Before the recorder will print the configuration on the chart, you will have to turn the printer off line. To do this, operate the HOME key to bring the top level Operator menu to the display.



Operate the CHART softkey

Operate the ON/OFF softkey

Operate the OFF or FAST OFF softkey (Note 1). After the 'Please Wait' message, note that an inverse 'P' appears at character 39 position to remind the user that the printer is off (Note 2).

Notes:

1. The FAST OFF softkey causes an almost immediate switching off of the chart.
The OFF softkey prints a 'Chart Off' message before switching the chart drive off.
2. If an instrument alarm is currently active, an inverse 'I' will appear instead of the inverse 'P'

```
05  >RANGE °C     Furn01A
2 LINE  MODE    HOLD  NEXT  PREVIOUS
```

```
Operator : Select a category
DISPLAY  CHART  ALARM  CHANNEL  MORE>
```



```
Chart : Select a category
ON/OFF  SPEED  LOG INT  MODE  SCALES
```



```
Printer is On line
OFF  FAST OFF
```



```
Please Wait
```

```
Printer is Off line
ON    PARK  ADVANCE  P
```

Operate the Home key again and enter configuration mode as described in section 2.3.2

2.3.11 PRINTING THE CONFIGURATION ON THE CHART (Cont.)

From the first top level configuration page, use the MORE> key repeatedly until the PRINT softkey appears. (How many MORE> keys there are, depends on how many options you have fitted in your recorder.)

'Maths', 'Total'r', 'Counter' and 'Timer' do not appear unless the options are fitted.

'M Card' and 'Comms' appear only if the options are fitted.

Operate the PRINT softkey.

Operate the CHANNEL softkey to initiate printing of the channel configuration on the chart. This will cause the recorder to print the configuration of all the channels fitted, which are not turned off.

Once this is finished, the display reverts to the previous top level configuration page.

```

Configuration : Select a category
INSTRM  CHART  CHANNEL  GROUP  MORE>
└──┘

Configuration : Select a category
EVENTS  LOGS   COPY   MATHS  MORE>
└──┘

Configuration : Select a category
TOTAL'R  COUNTER  TIMER  COMMS  MORE>
└──┘

Configuration : Select a category
TRANSFR  M CARD  DIAGS  AUTOCFG  MORE>
└──┘

Configuration : Select a category
ACCESS  ADJUST  PRINT  MORE>
└──┘

Configuration for group Furnace 1 temps
ALL  CHANNEL  TRACE  ALARM  MORE>
└──┘

Configuration print in progress
STOP

Configuration : Select a category
ACCESS  ADJUST  PRINT  MORE>
    
```

Figure 2.3.11 is an attempt to show how the channel configuration just completed should look when printed on the chart. The configuration printed includes all channels which are not configured to OFF. (In this case it is assumed that all channels except channel 5 are OFF, as delivered.)

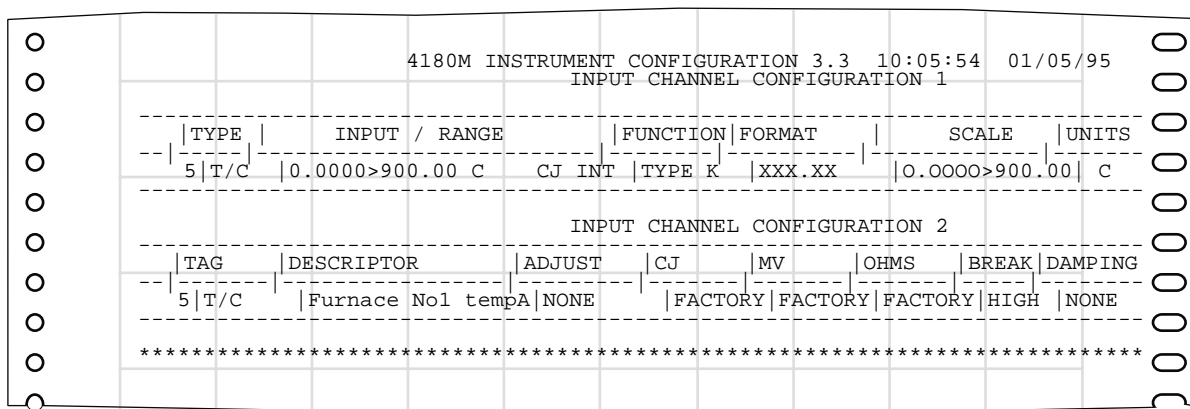

Figure 2.3.1 Channel configuration printout

2.4 COPY CONFIGURATION

Once a channel has been configured, you can copy its range, zone and alarm data to one or more other channels with similar configurations. The new channels retain their original trace and ident configurations.

EXAMPLE

To copy the configuration of channel 5 to channels 6 to 8, and then make the following changes:

Channel 6: Trace colour = Red, Descriptor = 'Furnace No 1 temp B', Tag = Furn01B

Channel 7: Trace colour = Blue, Descriptor = 'Furnace No 2 temp A', Tag = Furn02A

Channel 8: Trace colour = Green, Descriptor = 'Furnace No 2 temp B', Tag = Furn02B

Apart from these changes, the configuration of the channels (including alarm type and setpoint etc.) is the same as for channel 5.

2.4.1 Copy range and zone

Enter configuration as described in section 2.3.2 above.

Use the MORE> key, then the COPY key to access the copy menu page.

Use the CHANNEL softkey to access the channel copy page.

Note that the MATHS softkey appears only if the maths pack option is fitted.

Use the numeric keys and the cursor key to enter the source channel (5) and the destination channels (6 to 8).

Initiate the copy using the Enter key.



A further operation of the enter (or cancel) key causes a return to the previous (Select a category) page, from which you can select ALARM.



Enter source and destination channels, and initiate the copy as for copying channels above.

```
Configuration : Select a category
INSTRM  CHART  CHANNEL  GROUP  MORE>
```



```
Configuration : Select a category
EVENTS  LOGS   COPY   MATHS  MORE>
```



```
Configuration copy : Select a category
CHANNEL  MATHS  ALARM
```



```
Copy channel _1's range/zone config to
channel(s) 1 to 1
```

<5>

```
Copy channel _5's range/zone config to
channel(s) 1 to 1
```



```
Copy channel _5's range / zone config to
channel(s) _1 to 1
```

<6>

```
Copy channel _5's range / zone config to
channel(s) _6 to 1
```



```
Copy channel _5's range / zone config to
channel(s) _6 to _1
```

<8>

```
Copy channel _5's range / zone config to
channel(s) _6 to _8
```

Please wait

```
Copy channel _5's range / zone config to
channel(s) 6 to 8
```

```
Configuration copy : Select a category
CHANNEL  MATHS  ALARM
```



```
Copy Channel _1's alarm/job config to
channel(s) 1 to 1
```

2.4 COPY CONFIGURATION (Cont.)

2.4.2 Trace colour

Operate the Home key and enter CHANNEL configuration.



Select channel 6, and operate the TRACE softkey to call the trace definition page.

Use the cursor key twice, then the down arrow key to select red as the trace colour.

Use the enter key twice to return to the top level Channel Configuration page.

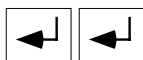

```
Configuration : Select a category
INSTRM  CHART  CHANNEL  GROUP  MORE>
```



```
Channel 5 : Select a category
RANGE  ALARM  ZONE  TRACE  IDENT
```

<6>

```
Channel 6 : Select a category
RANGE  ALARM  ZONE  TRACE  IDENT
```



```
Trace On          Line thickening Off
Colour A: Black   B Black
```



```
Trace On          Line thickening Off
Colour A: Black   B Black
```



```
Trace On          Line thickening Off
Colour A: Black   B Black
```



```
Trace On          Line thickening Off
Colour A: Red     B Black
```

2.4.3 Trace Identifiers

Use the IDENT softkey to call the first channel descriptor / tag page.

Use the Clear key to clear the default descriptor.

Enter the new descriptor as described in 2.3.8 above.

Use the page key then enter the new tag in the same way.

Use the enter key twice to return to the top level Channel Configuration page, and repeat the above for channels 7 and 8, making the appropriate changes.

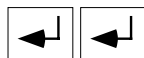

When complete, operate the Enter key to confirm the changes, then the Home key to return to the top level configuration page.

As a final check, you can print the channel and alarm configurations on the chart

```
Channel 6 : Select a category
RANGE  ALARM  ZONE  TRACE  IDENT
```



```
Descriptor Channel Number 6
```



```
Descriptor _
```

```
Descriptor Furnace No1 temp B
```



```
Tag 6
```

```
Tag Furn01B
```

```
Channel 6 : Select a category
RANGE  ALARM  ZONE  TRACE  IDENT
```

2.4 COPY CONFIGURATION (Cont.)

```

4180M INSTRUMENT CONFIGURATION 3.3 10:59:22 01/05/95
CHANNEL ALARM CONFIGURATION 1
-----
ENABLE          ALARM TYPE          UNITS
05_1  LATCHED    ABSOLUTE HIGH    780.00    C
06_1  LATCHED    ABSOLUTE HIGH    780.00    C
07_1  LATCHED    ABSOLUTE HIGH    780.00    C
08_1  LATCHED    ABSOLUTE HIGH    780.00    C
-----
CHANNEL ALARM CONFIGURATION 2
-----
AVERAGE  HYSTERESIS  DWELL
05_1     0.0000    0S
06_1     0.0000    0S
07_1     0.0000    0S
08_1     0.0000    0S
-----
CHANNEL ALARM JOBS
-----
05-1-1  ALARM      SOUND BUZZER WHILE ACTIVE
06-1-1  ALARM      SOUND BUZZER WHILE ACTIVE
07-1-1  ALARM      SOUND BUZZER WHILE ACTIVE
08-1-1  ALARM      SOUND BUZZER WHILE ACTIVE
-----
*****
4180M INSTRUMENT CONFIGURATION 3.3 10:55:37 01/05/95
INPUT CHANNEL CONFIGURATION 1
-----
TYPE  INPUT / RANGE  FUNCTION  FORMAT  SCALE  UNITS
5 T/C  0.0000>900.00 C  CJ INT  TYPE K  XXX.XX  0.0000>900.00 C
6 T/C  0.0000>900.00 C  CJ INT  TYPE K  XXX.XX  0.0000>900.00 C
7 T/C  0.0000>900.00 C  CJ INT  TYPE K  XXX.XX  0.0000>900.00 C
8 T/C  0.0000>900.00 C  CJ INT  TYPE K  XXX.XX  0.0000>900.00 C
-----
INPUT CHANNEL CONFIGURATION 2
-----
TAG  DESCRIPTOR  ADJUST  CJ  MV  OHMS  BREAK  DAMPING
5 T/C  Furnace No1 tempA  NONE  FACTORY  FACTORY  FACTORY  HIGH  NONE
6 T/C  Furnace No1 tempA  NONE  FACTORY  FACTORY  FACTORY  HIGH  NONE
7 T/C  Furnace No1 tempA  NONE  FACTORY  FACTORY  FACTORY  HIGH  NONE
8 T/C  Furnace No1 tempA  NONE  FACTORY  FACTORY  FACTORY  HIGH  NONE
-----
*****
    
```

Figure 2.4 Configuration print for channels 5 to 8

SECTION 3 : OPERATOR MENUS.

LIST OF CONTENTS

Section	Page
3.1 INTRODUCTION	3 - 5
TOP LEVEL OPERATOR MENU PAGE 1 (SECTION 3.2)	3 - 5
TOP LEVEL OPERATOR MENU PAGE 2 (SECTION 3.3)	3 - 5
TOP LEVEL OPERATOR MENU PAGE 3 (SECTION 3.4)	3 - 5
TOP LEVEL OPERATOR MENU PAGE 4 (SECTION 3.5)	3 - 5
3.2 TOP LEVEL OPERATOR MENU PAGE 1	3 - 6
3.2.1 DISPLAY softkey	3 - 6
3.2.2 Chart control page	3 - 9
ON/OFF SOFTKEY	3 - 9
SPEED SOFTKEY	3 - 9
LOG INT SOFTKEY	3 - 10
MODE SOFTKEY	3 - 10
3.2.3 View and acknowledge alarms page	3 - 11
3.2.4 Channel parameters and alarm setpoint adjustment page	3 - 12
3.3 TOP LEVEL OPERATOR MENU PAGE 2	3 - 14
3.3.1 Process page	3 - 14
3.3.2 KEYS softkey	3 - 15
3.3.3 TEXT softkey	3 - 16
EMBEDDED SEQUENCES	3 - 16
3.3.4 Manual log generation	3 - 17
3.4 TOP LEVEL OPERATOR MENU PAGE 3	3 - 18
3.4.1 CLOCK softkey	3 - 18
3.4.2 Job source search (JOB SRC softkey)	3 - 18
3.4.3 System error display	3 - 19
3.4.4 CONFIG softkey	3 - 19
3.5 TOP LEVEL OPERATOR MENU PAGE 4	3 - 20
3.5.1 M CARD softkey	3 - 20

This page is deliberately left blank

SECTION 3 OPERATOR MENUS

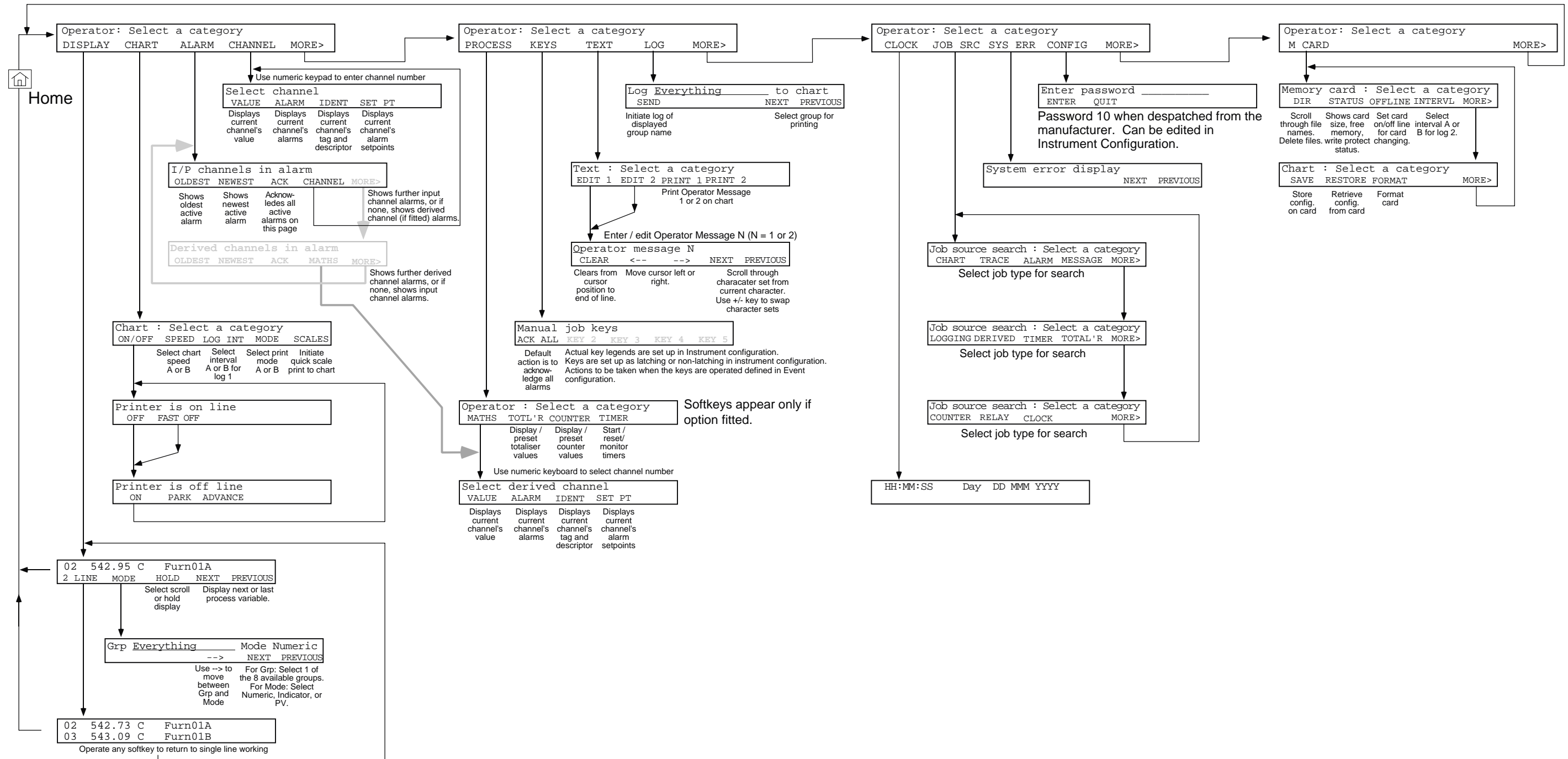

Figure 3.1 Operator menu structure

This page is deliberately left blank

SECTION 3 OPERATOR MENUS

3.1 INTRODUCTION

The operator menus (if enabled - see section 4.13) allow the operator to control certain basic recorder functions without having to use a password (i.e. without having to enter the recorder's configuration). The functions are as follows:

- 1 Chart control.
- 2 View alarm status and alarm acknowledgement.
- 3 Channel value display and alarm setpoint adjustment
- 4 Derived channel, totaliser, counter and timer option view and control (if option(s) fitted).
- 5 Direct initiation of 'jobs' via softkey operation.
- 6 Log initiation.
7. Editing and printing of two operator messages
- 8 Viewing of system time and date.
- 9 Job source search.
- 10 Viewing of system errors.
- 11 Entry to configuration using the password.
- 12 Control of memory card option functions.

The operator menus are arranged as a top level menu, with a number of lower levels accessed using softkeys, as depicted in figure 3.1.

Page one of the top level menu appears when the 'HOME' hardkey is operated one or more times.

Further pages are revealed by operating the MORE softkey on each page.

TOP LEVEL OPERATOR MENU PAGE 1 (For full description - see section 3.2)

```
Operator : Select a category
DISPLAY  CHART  ALARM  CHANNEL  MORE>
```

TOP LEVEL OPERATOR MENU PAGE 2 (Section 3.3)

```
Operator : Select a category
PROCESS  KEYS   TEXT   LOG    MORE>
```

TOP LEVEL OPERATOR MENU PAGE 3 (Section 3.4)

```
Operator : Select a category
CLOCK   JOB SRC  SYS ERR CONFIG  MORE>
```

TOP LEVEL OPERATOR MENU PAGE 4 (SECTION 3.5)

```
Operator : Select a category
M CARD                                     MORE>
```

Operation of MORE in menu page 4, causes a return to page 1.

The above displays show all options current at time of print. The actual layout of the displays will depend on which options are actually fitted.

3.2 TOP LEVEL OPERATOR MENU PAGE 1

3.2.1 DISPLAY softkey

Operation of the DISPLAY softkey calls the DISPLAY menu page. This page contains a process variable (PV) display and the softkeys described below. After approximately 3 seconds, the PV number changes to the next highest in the group, unless HOLD has previously been selected (in which case the softkey legend is SCROLL, not HOLD). The numeric +/- key can be used to scroll through the PVs in both SCROLL and HOLD mode.

```
Operator : Select a category
DISPLAY  CHART  ALARM  CHANNEL  MORE>
```

```
05 783.95 °C    Furn01A
2 LINE  MODE    HOLD    NEXT  PREVIOUS
```

- 2 LINE** Operation of this softkey causes the lower line of the display to show a second set of process variables, instead of the softkey captions. Enter or Cancel hardkeys, or any of the softkeys can be used to return to Single line display (i.e with softkeys on the bottom line)
- MODE** Operation of this key calls the 'Display mode / Group Select' page to the display. See figures 3.2.1a/b/c for an illustration of the different display modes available.

```
Gp Group descriptor— Mode Numeric
--> NEXT PREVIOUS
```

- Gp** Use NEXT and / or PREVIOUS softkeys to scroll through the available groups.
- Mode** Use NEXT and / or PREVIOUS softkeys to select the display mode:
- Numeric** Up to two PVs can be displayed as digital values on each display line, depending on the format selected for the group. This group format (section 4.5) defines whether any units, tags or descriptors appear alongside the value, and thus how many values can appear on each line (figure 3.2.1a).
- Indicator** The top line of the display contains channel number, digital value and units for the current channel together with an analogue (bar) interpretation of that value. The bottom line contains either softkey legends or, if 2-line working is in operation, a further channel display (figure 3.2.1b).
- PV Select** Allows up to 4 process variables to be selected for continuous display, independently of Group organisation. The display can contain either two or four PVs as shown in figure 3.2.1c.
To select a PV, the cursor is moved to the appropriate field, using the \bar{A} softkey or the numeric decimal point key. The type (Derived, Totaliser etc.) is then selected, using the TYPE softkey or the numeric key. Finally the required PV number is entered using the numeric entry keys.
- HOLD** Hold Operation of this softkey causes the process variable currently being displayed to remain at the top line, instead of being replaced by the next PV in the group. Operation also causes the legend to change to 'Scroll'.
- SCROLL** Operation of this softkey causes the normal PV scrolling process to take place, where each PV in the group is displayed in turn for about 3 seconds. Operation of the softkey also causes the legend to change to 'Hold'.
- NEXT** Causes the next 'page-full' of process variables (PVs) in the currently selected group, to be displayed. The number of PVs on a display page depends on the format (see above) selected in Group Configuration (described in section 4.5) and on whether one-line or two-line operation is selected (see '2-LINE' above).
- PREVIOUS** As 'NEXT' above, but the direction of scrolling is reversed.

3.2.1 DISPLAY SOFTKEY (Cont.)

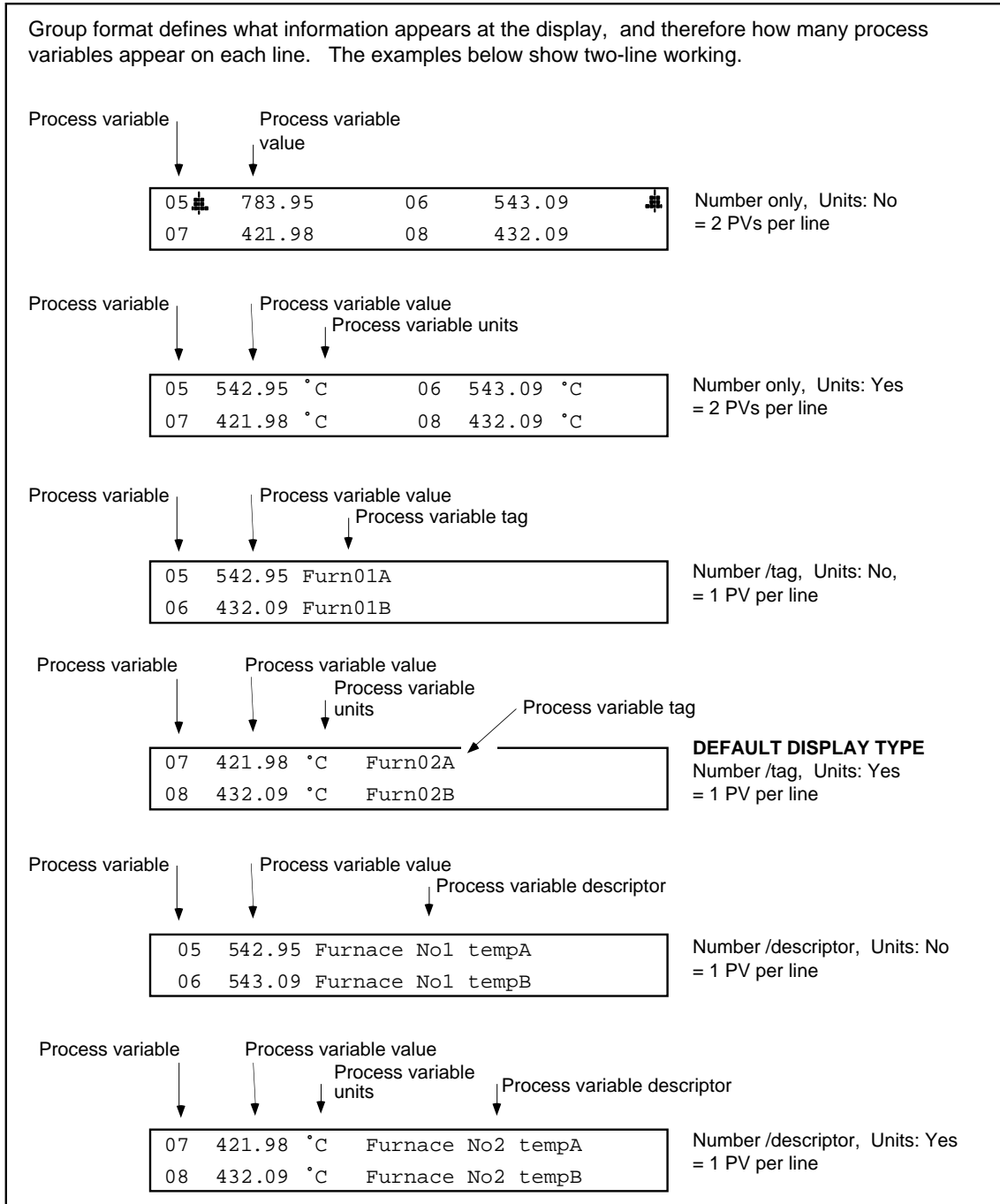

Figure 3.2.1a Numeric indication modes

3.2.1 DISPLAY SOFTKEY (Cont.)

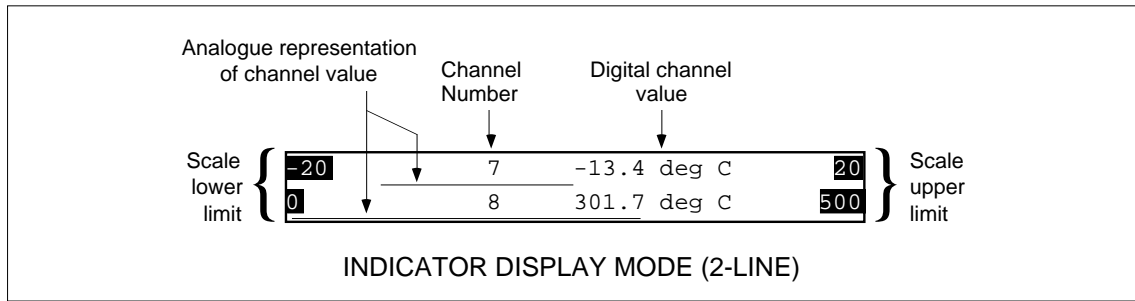

Figure 3.2.1b Indicator display mode (2-line)

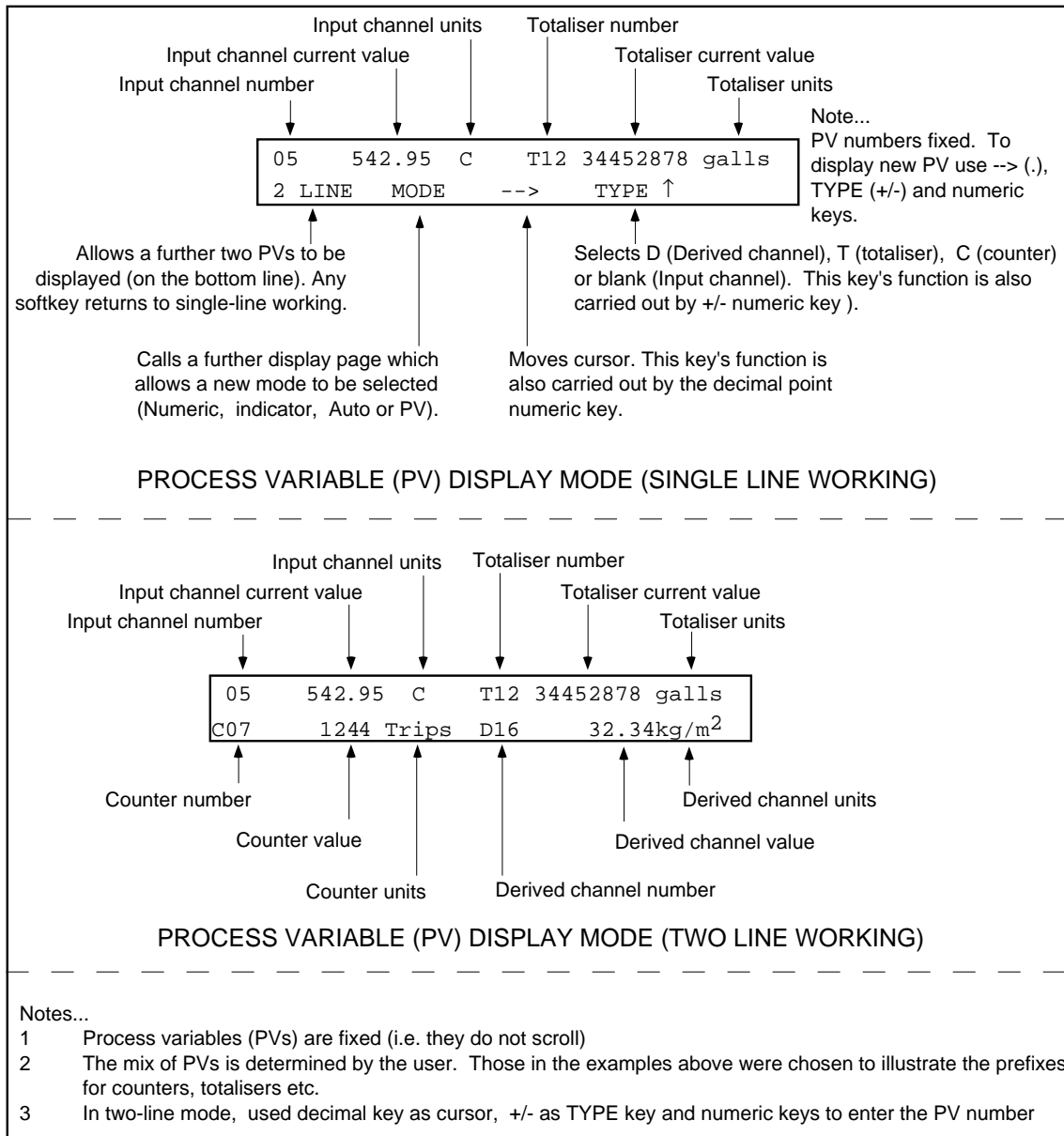

Figure 3.2.1c PV display modes

3.2.2 Chart control page

```
Operator : Select a category
DISPLAY  CHART  ALARM  CHANNEL  MORE>
```

Operation of the CHART softkey calls the menu page depicted below.

```
Chart: Select a category
ON/OFF  SPEED  LOG INT  MODE  SCALES
```

ON/OFF SOFTKEY

Operation of this soft key calls the chart on-off line page. With the chart on-line, the page is as depicted below.

```
Printer is On line
OFF  FAST OFF
```

OFF If the OFF softkey is operated, the recorder will continue to print logs and queued demand messages before printing a Printer Off message and then switching the chart drive off-line. After a 'Please Wait' message, the display changes to the off line display, with a 'Printer Off' status indicator towards the right-hand end of the display (inverse 'P').

FAST OFF If the FAST OFF softkey is operated, the recorder will finish printing the current line of text (if any) before switching the chart off-line. Demand messages are lost, but if logging is in operation when FAST OFF is operated, the remainder of the log will be printed when the chart is switched back on-line.

```
Printer is Off line
ON PARK  ADVANCE P
```

ON Switches the chart and print mechanism on. After a 'Please Wait' message, the display changes to the 'On-line' page shown above and the 'Printer Off' status indicator is extinguished.

PARK Causes the printhead to move to the centre of the chart. Charts and printheads should be changed only with the carriage parked in this way.

ADVANCE Operation of this key causes the chart to advance 16 cm. Once initiated, this advance cannot be stopped. Further operations of the softkey during advance will cause further chart advances to be queued.

SPEED SOFTKEY

Operation of the SPEED softkey allows the operator to switch between two chart speeds, known as chart speeds A and B, set up during chart configuration as described in section 4.3.

```
Chart speed is 120 mm/hr : Speed A
120 1200
```



```
Chart speed is 1200 mm/hr : Speed B
120 1200
```

The current chart speed is shown in the top line of the display. Chart speed A (120 mm/hr in the example above) is selected by operation of the left-most soft key; speed B (1200 mm/hr) by operation of the adjacent softkey.

3.2.2 CHART CONTROL PAGE (Cont.)

```
Operator : Select a category
DISPLAY  CHART  ALARM  CHANNEL  MORE>
```

```
Chart: Select a category
ON/OFF  SPEED  LOG INT  MODE  SCALES
```

LOG INT SOFTKEY

Log 1 can be initiated automatically, at one of two intervals, known as interval A and interval B, set up as a part of Chart configuration (Section 4.3). The content of Log 1 and its destination (chart or memory card -if fitted), is defined in 'Log Configuration' as described in section 4.7.

Operation of the LOG INT softkey allows the operator to switch between interval A and interval B. The current log interval is shown in the top line of the display, and the softkey captions show the alternative intervals. A log interval of, say, 00:30 means that log N°1 is printed on the chart every 30 minutes. A log interval of 00:00 stops the log being printed.

For example purposes only, in the displays depicted below, log interval A is 0 and log interval B is 1 hour.

```
Logging interval is 00:00 : Interval A
00:00  01:00
```



```
Logging interval is 01:00 : Interval B
00:00  01:00
```

If the memory card option is fitted, log 2 can also be initiated automatically at one of two 'archive intervals'. See section 4.1.4 for details.

MODE SOFTKEY

The recorder offers three 'Print Modes' which define the way in which information is presented on the chart. These modes are called: Trace priority, Text priority and Text only, and are fully described in section 4.3 (Chart configuration). Any one of these modes can be defined as Mode A and/or Mode B as a part of 'Chart configuration'.

The MODE softkey allows the operator to select print mode A or print mode B. The current mode is shown in the top line of the display and the softkey captions show the alternative print mode available. For example purposes only, in the displays depicted below Print Mode A is Trace priority and Print Mode B is Text priority.

```
Print mode is Trace priority : Mode A
TRC PRI TXT PRI
```

```
Print mode is Text priority :Mode B
TRC PRI TXT PRI
```

SCALES SOFTKEY

Operation of this softkey causes the 'Quick Scale Dump' page to appear. Operation of the START soft key causes the recorder to print on the chart, the scales of all channels currently set up to trace (section 4.4.5).

```
Quick Scale Dump - Trace will be broken
START
```

3.2.3 View and acknowledge alarms page

Operation of the ALARM softkey calls the first alarm overview page to the display. The top line of the display shows channels currently in alarm*. In the first example below, channels 3, 6 and 13 are in alarm. Alarms are presented in channel number order, with derived channels following measuring channels.

* Or channels with latching type alarms that were not acknowledged before going out of alarm.

Channels with one or more unacknowledged alarms have a flashing underline; channels with all active alarms acknowledged have a steady underline.

```
Operator : Select a category
DISPLAY  CHART  ALARM  CHANNEL  MORE>
```

```
I/P chans 03, 06, 13,
OLDEST  NEWEST  ACK  CHAN  MORE>
```

```
DV chans D01, D02, D03
OLDEST  NEWEST  ACK  CHAN  MORE>
```

OLDEST Shows details of the oldest currently active alarm. Allows the operator to scroll through the list of active alarms in chronological order and to acknowledge individual alarms as required.

NEWEST Shows details of the latest currently active alarm. Allows the operator to scroll through the list of active alarms in chronological order and to acknowledge individual alarms as required.

ACK Acknowledges all currently active, unacknowledged alarms on the display page.

Note: In general, to acknowledge all active alarms the operator need make only two or three keystrokes viz: HOME hardkey (if necessary) to enter the top level operator menu; ALARM softkey and finally ACK softkey.

CHAN Calls current channel display page (see section 3.2.4 below for details). Allows the operator to interrogate alarms channel by channel.

MORE Scrolls through further alarm pages.

3.2.4 Channel parameters and alarm setpoint adjustment page

Facilities View channel value and scale.
View channel alarms; View and/or modify alarm setpoints (thresholds)
View channel tag and descriptor. The tag (seven characters) is printed on the chart alongside the channel trace. The descriptor (17 characters) can be configured to appear at the display, and in logs.

Access

Home key (if necessary) followed
a) by operation of the CHANNEL softkey then numeric entry of the channel required OR
b) direct to the channel value display from the alarm page described in 3.2.3 above.

Operation of the CHANNEL softkey in the top level operator menu, calls the channel menu page, as depicted below. Once the page is displayed, a channel number (6 in the page depicted below) can be entered using the numeric keypad to the right of the display.

```
Operator : Select a category
DISPLAY  CHART  ALARM  CHANNEL  MORE>

                                <6>
Channel 6: Select a category
VALUE   ALARM  IDENT  SET PT
```

VALUE This causes the selected channel's details to be displayed, showing current value, units and descriptor.

```
06 783.98 °C Furnace No1 tempB
0 900
```

Operation of the Enter or Cancel hardkeys causes a return to the Select Channel display.

ALARM This causes details of the first of the channel's active alarms (if any) to be displayed. The top line shows the channel number and descriptor, the alarm number and type, and alarm time.

```
061 Furnace No1 tempB Hi 14:42:22
ACK NEXT PREVIOUS
```

ACK Operation of the ACK softkey causes the alarm to be acknowledged, if unacknowledged.

NEXT Operation of the NEXT softkey allows the channel's active alarms (if any) to be scrolled through.

PREVIOUS Operation of the PREVIOUS softkey allows the channel's active alarms (if any) to be scrolled through.

Operation of the Enter or Cancel hardkeys causes a return to the Select Channel display.

IDENT Operation of this softkey causes the channel's number, tag and descriptor to appear at the top line of the display. Other channels can be accessed using the NEXT and PREVIOUS softkeys.

```
06 Tag Ch6 Descriptor Chan 6
NEXT PREVIOUS
```

The Enter or Cancel hardkey is used to return to the Select Channel display.

(Continued)

3.2.4 CHANNEL PARAMETERS AND ALARM SETPOINT ADJUSTMENT PAGE (Cont.)

```
Operator : Select a category
DISPLAY  CHART  ALARM  CHANNEL  MORE>
                                     [v]
                                     [ ]
                                     <6>
```

```
Channel 6: Select a category
VALUE  ALARM  IDENT  SET PT
```

SET PT Allows the operator to change alarm setpoints, reference values etc. if permitted (see access configuration in section 4.13). Numeric entry keys are used to change the setpoint. Operation of the enter key causes the new value to be read into the recorder data base. The figures below show typical displays for the types of alarm available. (Underlines appear only if operator access is allowed)

```
61 Abs hi Set Point 780.0 [+]
CLEAR                               NEXT  PREVIOUS
```

```
62 Dev in Ref 10.00 Dev1.000
CLEAR                               -->  NEXT  PREVIOUS
```

```
63 Roc rise Chng1.000 per 1 s [+]
CLEAR  PERIOD+  -->  NEXT  PREVIOUS
```

```
121 Digital Active Message
```

CLEAR Resets the entered values to zero.

NEXT Calls the next alarm for the channel.

PREVIOUS Calls the previous alarm for the channel.

--> This softkey allows the active (i.e. flashing) cursor to be moved between the configurable fields. Once the flashing cursor is below the relevant field, the numeric or PERIOD keys are used to enter the new value.

PERIOD+ Appears only with Rate-of-Change alarms, and allows scrolling of the 'period' field. (Numeric keys cannot be used to enter this value.)

3.3 TOP LEVEL OPERATOR MENU PAGE 2

3.3.1 Process page

Operation of the PROCESS softkey calls the process menu page to the display if any options are fitted. If no options are fitted, then a message 'No process options fitted' will appear for three seconds.

```
Operator : Select a category
DISPLAY  CHART  ALARM  CHANNEL  MORE>
```



```
Operator : Select a category
PROCESS  KEYS   TEXT   LOG   MORE>
```



```
Operator : Select a category
MATHS   TOTAL'R  COUNTER  TIMER
```

MATHS Operation of this softkey calls the DERIVED CHANNEL menu page as depicted below.

```
Channel D01: Select a category
VALUE  ALARM  IDENT  SET PT
```

Use the numeric keys to enter the channel number. The VALUE page includes a RESET softkey if applicable. The remaining displays are as described for measuring channels (section 3.2.4 above).

TOTAL'R Operation of this softkey allows totaliser values to be viewed and pre-set if required. The relevant totaliser (1 to 12) is selected by use of the numeric entry keys.

```
Totaliser T 1 : Select a category
VALUE  EDIT
```

VALUE Operation of this softkey displays the value of the selected totaliser. The totaliser value can be set to the pre-set value, using the PRESET softkey.

NEXT and **PREVIOUS** softkeys call other totalisers' values to the display.

```
T1 12345678 Units -Descriptor-
PRESET  NEXT  PREVIOUS
```

EDIT Allows the Pre-set value to be changed using the numeric keys, if operator access allowed.

```
Preset is 12000.000
```

COUNTER Similar to the totaliser described immediately above allowing the counter to be set to a pre-set value, from which it will count.

3.3.1 PROCESS PAGE (Cont.)

```
Operator : Select a category
DISPLAY  CHART  ALARM  CHANNEL  MORE>
```



```
Operator : Select a category
PROCESS  KEYS   TEXT   LOG    MORE>
```



```
Operator : Select a category
MATHS   TOTAL'R COUNTER  TIMER
```

TIMER Operation of this softkey calls the timer display page and the required timer (N) is selected using the numeric entry keys. Duration / Repeat period are set up in timer configuration (section 5.4).

```
Timer N : Select a category
CONTROL IDENT
```

CONTROL Calls the following control page if the timer is disabled (See section 5.4)

```
Timer N disabled
```

OR, if the timer is enabled:

```
Timer N waiting for start
START
```

START Causes the timer to start.

```
Timer N duration left to run DDDDDD
RESET
```

```
Timer N repeats in DDdy HHhr MMmn SSs
RESET
```

RESET Resets the timer leaving it waiting to be started again.

IDENT Calls the timer ident page. A 20-character descriptor can be entered as a part of each timer's configuration (section 5.4).

```
Timer N DDDDDDDDDDDDDDDDDDDDDDD
NEXT  PREVIOUS
```

NEXT Calls the next timer's ident page to the display

PREVIOUS Calls the previous timer's ident page to the display.

3.3.2 KEYS softkey

Operation of this softkey calls the user-configured softkey captions (section 4.2.1 - Instrument configuration Page 2) to the display. The softkeys are used to allow the operator to trigger jobs. Use the Cancel or Enter key to return to the top level menu.

3.3.3 TEXT softkey

Applications Generating notes to print on the chart.

Adding batch numbers to the chart.

Entering the Operator's name to be embedded in other messages.

Access HOME key (if necessary), followed by operation of the MORE and TEXT softkeys

The TEXT softkey allows the operator to edit up to two messages, one or both of which can then be printed on the chart, using the PRINT 1 and / or PRINT 2 softkeys. Either of these messages can be embedded in other messages (Section 4.2).

```
Operator : Select a category
DISPLAY  CHART  ALARM  CHANNEL  MORE>
```

```
Operator : Select a category
PROCESS  KEYS   TEXT   LOG    MORE>
```

```
Text: select a category
EDIT 1  EDIT 2  PRINT 1  PRINT 2
```

Operation of the EDIT 1 or EDIT 2 softkey calls the edit page to the display.

```
Text of operator message number 1 or 2
CLEAR  <--  -->  NEXT  PREVIOUS
```

CLEAR	Clears the message from the cursor position (inclusive) to the end of the line.
<—	Moves cursor left
—>	Moves cursor right
NEXT	Selects next character in the currently selected character set
PREVIOUS	Selects previous character in the currently selected character set

EMBEDDED SEQUENCES

The messages can include one or more embedded sequence, each of which causes the current value of a particular variable (e.g. time, date, value of channel N etc.) to be included, automatically, in the message when printed. The sequences are embedded using the < and > characters (delimiters) to separate them from normal text. The available sequences, which must be entered as shown, are as follows:-

<TIME>	Embeds the current time in hh:mm:ss format
<DATE>	Embeds the current date in the format defined in the instrument configuration i.e. DD/MM/YY or MM/DD/YY.
<OP1>	Not valid for Operator Messages. For Custom or Alarm Messages (section 4.2.1) <OP1> embeds operator message N° 1. If Operator message N° 1 itself contains embedded sequence commands, these will not be expanded.
<OP2>	As <OP1>, but for operator message N° 2.

The remaining sequences require both a source and a type to be defined as <ITEM-TYPE> or <ITEM.TYPE>. If the ITEM is a channel, and the hyphen (-) format is used, then the TYPE is underlined (in red) if it has an active or unacknowledged alarm associated with it. If the dot (.) format is used, or if the ITEM is not a channel, this underlining is not carried out.

(Continued)

3.3.3 TEXT PAGE (Cont.)

EMBEDDED SEQUENCES (Cont.)

ITEMS

Blank	Use the triggering item itself (e.g. alarm, totaliser) as the source.
nn	Use measuring channel nn as the source.
Dnn	Use derived channel nn as the source.
Tnn	Use totaliser N° nn as the source.
Cnn	Use counter N° nn as the source.
Enn	Use event N° nn as the source.
tnn	Use timer N° nn as the source.

TYPES

PV	Causes the ITEM's process value to be embedded.
TA	Causes the ITEM's tag to be embedded.
DE	Causes the ITEM's descriptor to be embedded.
UN	Causes the ITEM's units string to be embedded
NO	Causes the ITEM's identification number (e.g.. 11, T2, D43) to be embedded.

EXAMPLES

The message <TIME><DATE><.TA><-.PV><..UN> would cause the current time and date, followed by the tag, process value (underlined if in alarm) and units, to be printed for the message's triggering source.

For a specified ITEM (measuring channel 12 in this example) <TIME><DATE><12.TA><12-PV><12.UN> would result in the same message being printed, but for channel 12 instead of the triggering source.

3.3.4 Manual log generation

This softkey appears only if operator access to log generation has been enabled (section 4.13). Allows the operator to initiate the printing of any of the logs.

```
Operator : Select a category
DISPLAY  CHART  ALARM  CHANNEL  MORE>
```

```
Operator : Select a category
PROCESS  KEYS   TEXT    LOG    MORE>
```

```
Log Everything to chart
SEND                                NEXT  PREVIOUS
```

Log ----	Presents the title of the group Everything. The remaining eight groups can be scrolled through using NEXT and PREVIOUS softkeys. Destination of the log (chart or memory card filename) is set up in log configuration (section 4.7).
SEND	Causes selected log to be initiated.

3.4 TOP LEVEL OPERATOR MENU PAGE 3

```
Operator : Select a category
DISPLAY  CHART  ALARM  CHANNEL  MORE>
└───┘

Operator : Select a category
PROCESS  KEYS   TEXT   LOG     MORE>
└───┘

Operator : Select a category
CLOCK  JOB SRC  SYS ERR CONFIG  MORE>
```

3.4.1 CLOCK softkey

Operation of the CLOCK softkey calls the following page to the display, allowing the operator to check the system time and date. Setting time and date is part of Instrument Configuration described in section 4.2.1.

```
HH:MM:SS   Day DD MMM YYYY
```

3.4.2 Job source search (JOB SRC) softkey

Function To allow the operator to find all the triggers which have been set up to initiate a particular job.

Operation of the JOB SRC softkey calls the first of the following pages to the display. Subsequent pages are called by operation of the MORE> softkey.

```
Job source search : Select a category
CHART  TRACE  ALARM  MESSAGE  MORE>

Job source search : Select a category
LOGGING DERIVED  TIMER  TOTAL'R  MORE>

Job source search : Select a category
COUNTER  RELAY  CLOCK  MORE>
```

Operation of any of the category softkeys presents the menu of jobs associated with the selected category (section 4.1.3). Use of the next and / or previous softkeys allows the menu items to be scrolled through. The first item in the CHART category is depicted as an example, below.

```
Chart printer on line
NEXT  PREVIOUS
```

Once the required job has been located, operation of the enter key initiates a search for all trigger sources for that job.

After a 'Please wait' message, the job sources will be presented at the bottom line of the display. Up to 8 sources can be displayed on one page, but if there are more than eight, the first six are displayed along with a 'MORE>' softkey to allow access to remaining sources.

(Continued)

3.4.2 JOB SEARCH SOURCE (Cont.)

```
Chart printer on line
011, D032, E06, T04, C01, t05, MORE>
```

Where

- Normal measuring channels are presented without prefix.
- Derived channels have the prefix 'D'.
- Event numbers have the prefix 'E'.
- Totaliser numbers have the prefix CAPITAL 'T'.
- Timer numbers have the prefix 't'.
- Counters have the prefix 'C'.
- Alarm numbers are presented as subscript numbers after the associated channel number.

Thus, in the above example, the chart is put on-line by Channel 1, Alarm 1 or Derived channel 3, Alarm 2 or Event 6 or Totaliser 4 or Counter 1 or Timer 5 or by further sources on subsequent pages (MORE>).

3.4.3 System error display

```
Operator : Select a category
DISPLAY  CHART  ALARM  CHANNEL  MORE>
```



```
Operator : Select a category
PROCESS  KEYS   TEXT   LOG    MORE>
```



```
Operator : Select a category
CLOCK   JOB SRC  SYS ERR CONFIG  MORE>
```

System errors can be viewed by operating the SYS ERR key in the operator menu. This causes system errors to be presented one at a time on the top line of the display. If more than one system error is operative, the 'page' symbol appears as the right-most character of the top line, and the NEXT and PREVIOUS keys can be used to scroll through the list (section 2.2.2).

3.4.4 CONFIG softkey

```
Enter Password _____
QUIT  ENTER
```

Entry of the correct password allows access to the configuration menus described in section 4. The recorder is despatched with a password of 10, but this can be customised as a part of 'Instrument' configuration. If set to a single '0', the configuration menus are freely enterable from the Operator menus without the need for password entry.

3.5 TOP LEVEL OPERATOR MENU PAGE 4

3.5.1 M CARD softkey

A full description of this option is to be found in the Memory Card Instruction Manual supplied with every recorder fitted with the option.

```
Operator : Select a category
DISPLAY  CHART  ALARM  CHANNEL  MORE>
```

```
Operator : Select a category
PROCESS  KEYS   TEXT   LOG    MORE>
```

```
Operator : Select a category
CLOCK   JOB SRC  SYS ERR CONFIG  MORE>
```

```
Operator : Select a category
M CARD                                     MORE>
```



```
Memory card : Select a category
DIR        STATUS CHT CPY OFFLINE  MORE>
```

```
Memory card : Select a category
REPORT INTERVL  SAVE  RESTORE  MORE>
```

```
Memory card : Select a category
FORMAT                                             MORE>
```

DIR	Allows the operator to scroll through the files on the card and to delete any which are unwanted.
STATUS	Allows the operator to view the number of unused kB available on the card.
OFFLINE	Allows data transfer to the card to be stopped. This allows a full card to be changed without loss or corruption of data.
INTERVL	Allows the user to select archiving interval A or B for log 2. Log 2 may thus be printed on the chart or logged to memory card, automatically at regular intervals. (See also section 4.1.4)
SAVE	Allows a configuration to be saved on a formatted memory card
RESTORE	Allows the recorder's configuration, previously saved on the memory card, to be retrieved to any similar recorder fitted with the memory card option.
FORMAT	Allows a memory card to be formatted prior to use.

Operator access to some or all of the above functions can be disabled as described in section 4.13.

SECTION 4 : CONFIGURATION.

LIST OF CONTENTS

Section	Page
4.1 INTRODUCTION	4 - 5
4.1.1 Password	4 - 5
4.1.2 Text strings	4 - 5
4.1.3 Jobs	4 - 6
4.1.4 Logs	4 - 7
LOGGING TO CHART	4 - 7
LOGGING TO MEMORY CARD	4 - 7
4.2 INSTRUMENT CONFIGURATION	4 - 8
PAGE 1 PARAMETERS	4 - 9
PAGE 2 PARAMETERS	4 - 10
PAGE 3 PARAMETERS	4 - 11
PAGE 4 PARAMETERS	4 - 11
4.3 CHART CONFIGURATION	4 - 12
4.3.1 Chart parameters	4 - 13
4.3.2 Print modes	4 - 13
TRACE PRIORITY	4 - 13
TEXT PRIORITY	4 - 13
TEXT ONLY	4 - 13
4.4 CHANNEL / ALARM CONFIGURATION	4 - 14
4.4.1 Channel address allocation	4 - 14
ADDRESSING RULES	4 - 14
4.4.2 Channel configuration: Range	4 - 15
INPUT CHANNELS	4 - 15
PAGE ONE PARAMETERS	4 - 16
PAGE TWO PARAMETERS	4 - 17
PAGE THREE PARAMETERS	4 - 17
OUTPUT CHANNELS	4 - 18
4.4.3 Channel configuration: Alarms	4 - 20
ALARM ACTION	4 - 20
SET PT SOFTKEY PAGE ONE PARAMETERS	4 - 23
SET PT SOFTKEY PAGE 2 PARAMETERS	4 - 23
JOBS SOFTKEY	4 - 24
4.4.4 Channel configuration: Zone	4 - 25
ZONE PARAMETERS	4 - 25
4.4.5 Channel configuration: Trace	4 - 26
DEFAULT CHANNEL COLOURS	4 - 26
4.4.6 Channel configuration: Ident	4 - 27
4.5 GROUP CONFIGURATION	4 - 28
4.5.1 Group parameters	4 - 28
4.6 INTERNAL EVENT CONFIGURATION	4 - 29
EXAMPLE	4 - 29
4.6.1 Event parameters	4 - 30
4.7 LOG CONFIGURATION	4 - 31
4.7.1 Log parameters	4 - 31
4.8 COPY CONFIGURATION	4 - 32
4.8.1 Rules for copying	4 - 32
4.9 OPTIONS CONFIGURATION	4 - 33

(Continued)

Section 4 List of contents (Cont.)

Section	page
4.10 TRANSFER CONFIGURATION	4 - 33
4.10.1 Transfer parameters	4 - 33
4.11 DIAGNOSTICS	4 - 34
4.11.1 SBC	4 - 34
4.11.2 Board	4 - 34
4.11.3 Pens	4 - 34
4.11.4 Relays	4 - 34
4.11.5 Output	4 - 34
4.11.6 CJ Temp	4 - 37
4.11.7 Comms	4 - 37
TALK	4 - 37
LISTEN	4 - 37
LOOP BACK	4 - 37
4.11.8 Default	4 - 37
4.11.9 M Card	4 - 37
TEST	4 - 37
VERSION	4 - 37
4.11.10 Display	4 - 37
4.12 AUTOCONFIGURATION	4 - 38
4.13 OPERATOR ACCESS CONFIGURATION	4 - 38
4.14 ADJUST	4 - 41
4.14.1 Input adjust	4 - 41
REMOVE	4 - 42
VIEW	4 - 42
4.14.2 Output adjust	4 - 43
4.14.3 Chart adjust	4 - 43
4.14.4 CALIB softkey	4 - 44
CJC CALIBRATION	4 - 45
VIEW	4 - 46
4.15 PRINT CONFIGURATION	4 - 46

SECTION 4 CONFIGURATION

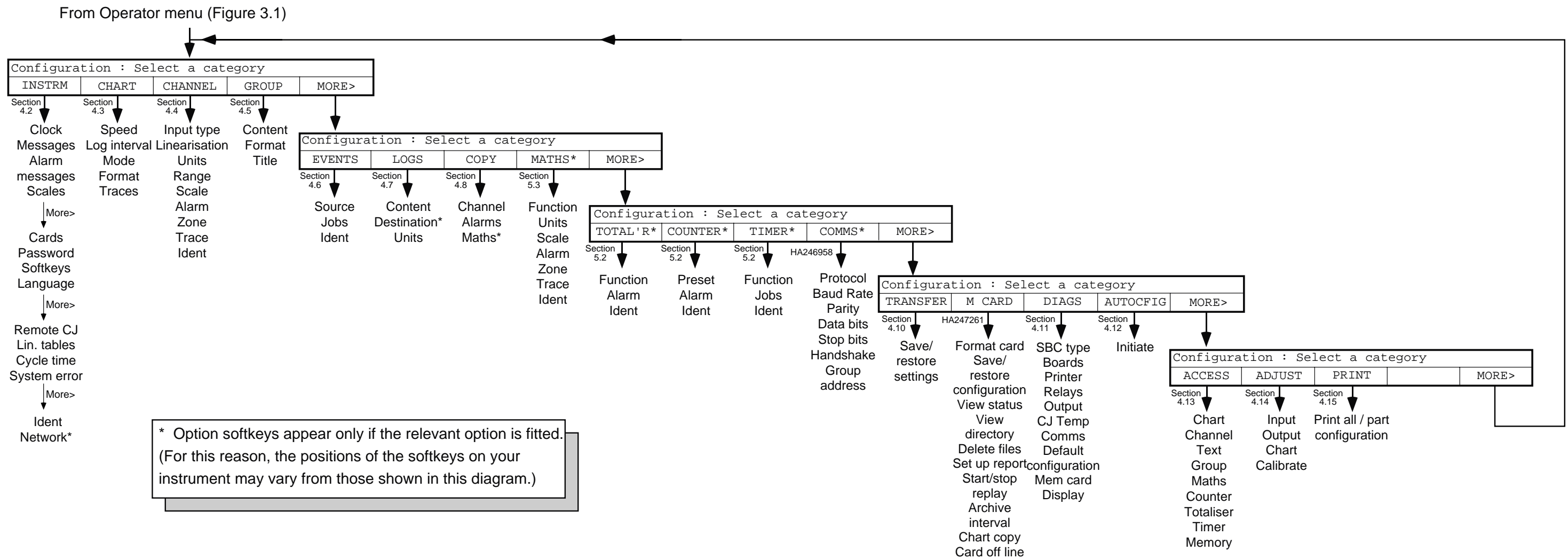

Figure 4.1
Configuration menus

This page is deliberately left blank

4.1 INTRODUCTION

Note: In order to help new users, a configuration guide appears as Section 2 to this manual. This gives step-by-step instructions to allow the configuration of a single input channel to be carried out and then copied to other channels.

The configuration of the recorder is carried out in a number of separate operations (categories) as listed below in the order in which they appear at the recorder display. See figure 4.1.

- | | | |
|-----------------------|-----------------------------|----------------------------|
| 1. Instrument | 8. Maths functions (option) | 14. Configuration transfer |
| 2. Chart | 9. Totalisers (option) | 15. Diagnostics |
| 3. Channels / alarms | 10. Counters (option) | 16. Autoconfiguration |
| 4. Groups | 11. Timers (option) | 17. Operator access |
| 5. Events and jobs | 12. Memory card (option) | 18. Adjust |
| 6. Logs | 13. Communications (option) | 19. Configuration print |
| 7. Configuration copy | | |

As will become clear, the techniques used in the configuration of the recorder are largely the same as those for the Operator Menu described in section 3 above. For this reason, large parts of this configuration section are laid out more as reference material than as descriptive matter.

TIMEOUT

Unless one of the activities listed below is taking place, a return to the normal background display will be made after 4 minutes of keyboard inactivity. Should this happen, the configuration menus can be re-entered only after a further entry of the password (see section 4.1.1 below).

Timeout will not occur under the following conditions:

Changes to CARDS configuration are being confirmed

Autoconfiguration in progress

Configuration save or restore (to memory card) in progress

Memory card being formatted

Memory card is offline

Configuration printing is in progress

Channels are being copied

Channel adjustment, Input calibration or Cold Junction calibration is in progress

Recorder is in diagnostics.

4.1.1 Password

In order to prevent unauthorised access to the recorder configuration, a password protection system operates. **When dispatched from the factory the password is 10**, but this can be changed as a part of the Instrument Configuration described below.

If a password of a single 0 is set up, the configuration menus can subsequently be accessed directly from the operator menu (CONFIG softkey) without a password being needed.

4.1.2 Text strings

A number of configuration items (e.g. channel descriptor) require text to be entered and the technique for achieving this is described in section 2.2.3. It is also possible to have time, date, process variable value etc. embedded in messages to be printed on the chart or to appear at the display as described in section 3.3.3

4.1.3 Jobs

A 'job' is defined as an action that can be initiated by an alarm, a timer, a counter etc. Jobs can be configured to be active continuously whilst the initiating source is active (or inactive) (e.g. Select chart speed B), or to carry out a particular task (e.g. Increment totaliser N°3) as the result of a single trigger going active or inactive.

Up to two jobs can be initiated by each alarm, timer etc. as shown in figure 4.1.3 below.

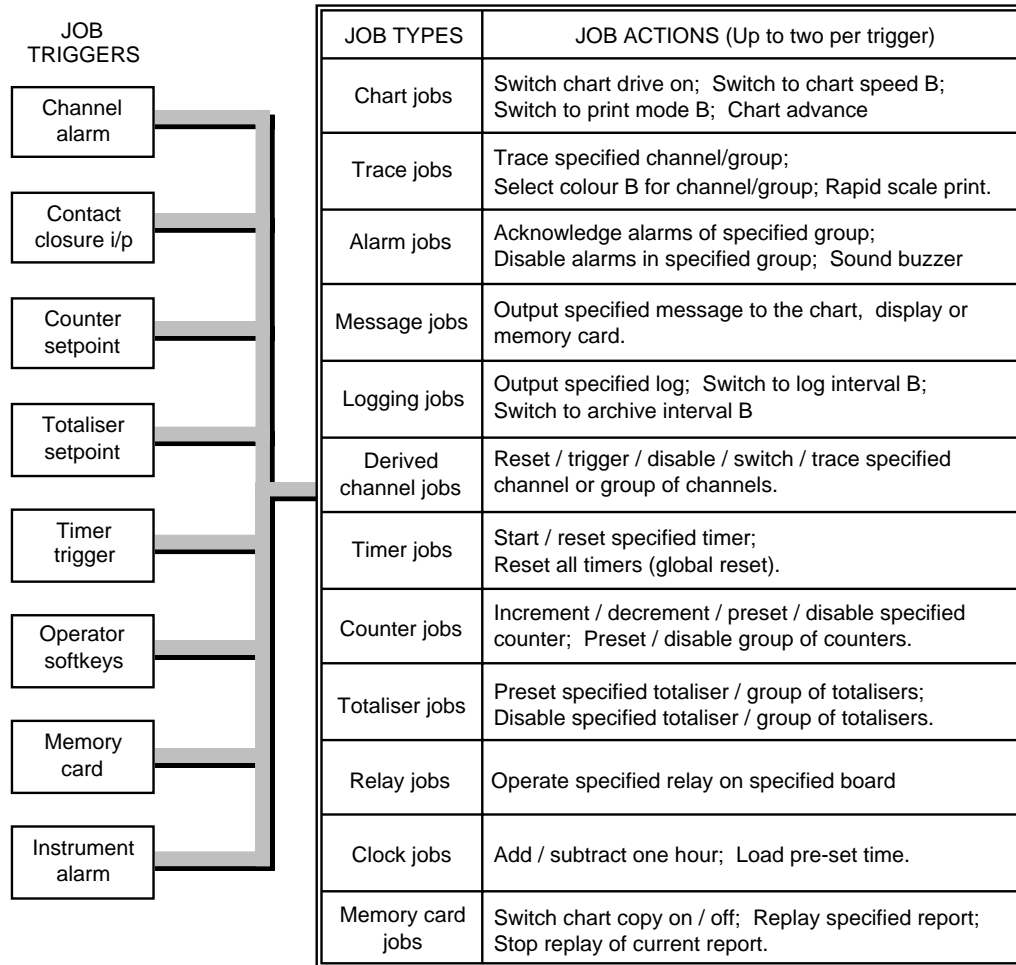

Figure 4.1.3 Job triggers and actions

4.1.4 Logs

Logs are alpha-numeric reports showing the current values of a group of variables. Which group is allocated to which log is set up as a part of the log configuration (section 4.7), and the content of each group is set up as a part of Group Configuration (Section 4.5). Logs can either be printed on the chart, or if the relevant option is fitted, they can be directed to a memory card. Log destination (chart or card) is set up as a part of log configuration (section 4.7).

LOGGING TO CHART

When logging is in operation, the relevant values are printed across the full width of the chart.

The number of values per line depends on how much information (e.g. descriptors, tags) is to be included (group configuration - section 4.5).

Up to six logs are available, each of which can be allocated a 'group' as described in section 4.7. The printing of a log can be initiated in the following ways:

- a) By the operator (section 3.3.3)
- b) As a result of job action (section 4.1.3)
- c) For log 1 only, automatically, at one of two fixed time periods (log intervals A and B).
- d) If memory card archiving software is fitted, log 2 can also be printed automatically at one of two archive intervals set up as a part of memory card configuration.

OPERATOR INITIATION

As described in section 3.3.3, log printing can be initiated by the operator, at any time, from the LOG softkey in the level 1 Operator Menu.

JOB ACTION

As shown in figure 4.1.3, one of the jobs types available is 'Logging'. Within this category, a particular log number can be selected for printing when the job becomes active, and/or the logging interval for log 1 can be selected to 'B'.

LOG INTERVAL

As detailed in section 4.3 below, two log intervals (A and B) can be entered as a part of the chart configuration for automatic printing of log 1. Log interval A or B is selected for use from the top level Operator menu (section 3.2.2) or by job action (section 4.1.3). The intervals are in hours and minutes; an entry of 0:0 disabling automatic log printing. As supplied by the factory, log interval A is set to 00:00 (off); interval B to 01:00 (1 hour).

ARCHIVE INTERVAL

If any of the memory card logging or archiving options is fitted, two archive intervals (A and B) can be entered as a part of the memory card configuration for automatic printing of log 2. Interval A or B is selected for use from the top level Operator menu or by job action (section 4.1.3). The intervals are in hours, minutes and seconds; an entry of 00:00:00 disabling automatic log printing. As supplied by the factory, both archiving intervals are set to 00:00:00 (off). Refer to the Memory Card Manual for further details.

LOGGING TO MEMORY CARD

Logging to memory card is initiated in exactly the same way as logging to chart, described above, except that the log destination (set up in log configuration) is a file name instead of 'to chart'. Refer to the Memory Card Manual for full details.

4.2 INSTRUMENT CONFIGURATION

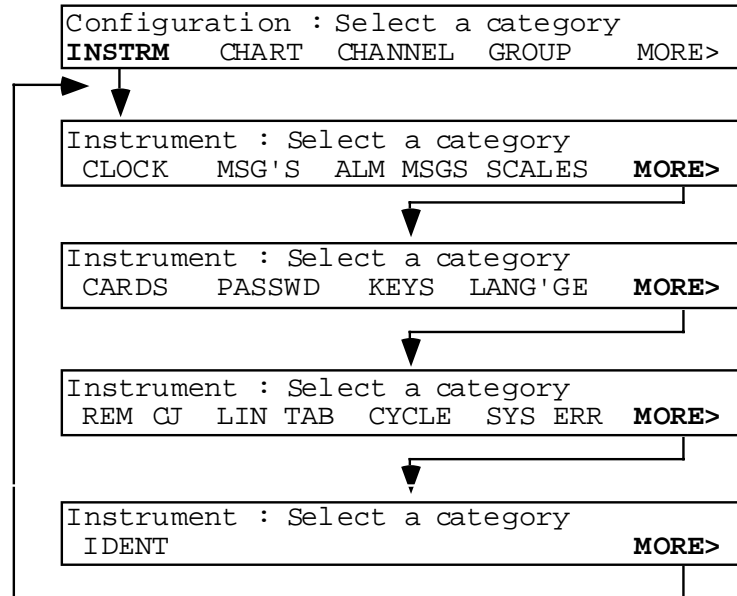

Figure 4.2 Instrument configuration

The instrument configuration allows the following items to be set up:

1. Current Date and Time (CLOCK softkey). It should be noted that adding or subtracting an hour can be done using 'Clock' jobs, simplifying time changes at Spring and Autumn.
2. A Preset Time (CLOCK soft key), used to synchronize clocks of multiple instruments.
3. The date format (DD/MM/YY or MM/DD/YY).
4. Messages (up to 10 printed, displayed or archived by job action) (MSG'S softkey). These messages may contain embedded sequences as described in section 3.3.3
5. Alarm on/off and alarm acknowledgement messages, including the time at which the action occurred, can be printed automatically if the messages are enabled (ALM MSG'S softkey). The messages apply only to latching and non-latching alarms on measuring or derived channels. This saves the user having to set up jobs to trigger user messages.
6. Customised scales (SCALES softkey). This allows the user to define exactly what information is to appear where on the printed scale. Up to four scales can be set up, and any channel can be configured to use one of these scales, instead of the normal automatic scaling. See section 4.4.4 - Channel zone.
7. Which card type is located in which slot is usually determined automatically using AUTOCONFIG. This can be overruled from within the CARDS pages to allow slots to be used for COMMS, TEST or NETWORK inputs, none of which requires an I/O board to be fitted. Further, it is possible to 'shutdown' cards I/O boards to allow them to be removed without generation of spurious alarms.
8. A new password can be entered (PASSWD softkey). **The recorder is despatched from the factory with the password '10'.**
9. The five softkeys can be used as event sources. The KEYS softkey allows the labels which are to appear above the keys to be entered, and the key action to be defined as latching or non-latching. The jobs to be carried out when the softkeys are operated are set up in Event Configuration (section 4.6).
10. The display language can be selected as French, German or English (LANG'GE softkey).
11. One or more channel numbers can be defined as remote CJ inputs (REM CJ softkey). This allows either a single channel to be used for all channels set up for remote CJ, or a channel can be set up as remote CJ input for each input card. The remote CJ temperature units can also be set up.
12. Two user linearisation tables of up to 32 points each can be entered as input / output pairs.

(Continued)

4.2 INSTRUMENT CONFIGURATION (Cont.)

13. A recorder iteration period can be set, which overrides the normal 1 second period. If an error message is required when the recorder cannot meet the specified iteration rate, then this can also be set up.
14. System errors can be displayed, and where relevant, cleared.
15. A recorder identifier can be entered for use in logging to memory card (if fitted), and with networked instruments.

As can be seen from figure 4.2 above, entry is by operation of the INSTRM softkey in the top level configuration menu. In order to return to higher levels of menu, the Cancel, Enter or Home key is operated.

PAGE 1 PARAMETERS

CLOCK	Time	Allows entry of Hours and Minutes. Entry method: numeric keys. The clock starts when the 'Enter' key is operated.
	Date	Allows entry of Day number, Month and Year. Entry method: field scroll keys (month); numeric entry (Day, month and year). Day name is automatically linked to the rest of the date.
	Preset time	Allows entry of pre-set hours and minutes for job action (e.g. clock synchronization among multiple recorders). Entry method: numeric keys.
	Date format	Allows Day/Month/Year (DD/MM/YY) or Month/Day/Year (MM/DD/YY) to be chosen for date display/archiving etc.)
MSG'S	Select Customised Message.	Entry method: Numeric keys. (1 to 10)
	EDIT	Presents selected message text for editing. See sections 2.2.3 and 3.3.3
ALM MSG'S	Alarm on/off messages	Scrollable Yes or No to enable / disable, respectively, the automatic printing of alarm on and alarm off messages. (Format of messages is: HH:MM Alarm(s) on (off) CCn, DCCn etc, where HH:MM is the time at which the alarms changed state, CC is the channel number and n is the alarm number (1 to 4). DCC is used to denote a derived channel number.)
	Alarm acknowledgement msgs	Scrollable Yes or No to enable/disable, respectively, the automatic printing of alarm acknowledgement messages.
SCALES	Select customised scale EDIT	Entry method: Numeric entry keys. (1 to 4). Presents selected scale for editing. The lower line of the display initially represents the first 40 of the 77 positions at which characters can be printed on the chart. The top line shows the current cursor position. The right arrow (cursor) key is used to move the cursor along the scale. When the fortieth character is reached (i.e. the right-hand end of the display line further operations of the cursor key result in the scale's apparently moving left, until cursor position 77 is reached. Further operation of the cursor key returns to the beginning of the scale. Any alphanumeric character can be entered at any of the 77 positions using either the field scroll keys or the numeric keyboard. Operation of the 'Enter' key confirms the new scale. 'Cancel' or a further 'Enter' returns to the 'Select customised scale' page.

4.2.1 INSTRUMENT PARAMETERS (Cont.)**PAGE 2 PARAMETERS**

CARDS	Addr1 to Addr9	Allows the card type for each address to be set up (see section 4.4.1 for addressing rules), and to be defined as either enabled or shutdown. 'Shutdown' allows a card to be removed from its slot without any resulting alarms etc. being generated and also allows the recorder I/O to be configured even if the cards are not fitted. The page scroll keys are used to scroll through Empty, Universal i/p, Relay, Comms, Test, 8 channel o/p, 16 channel i/p, 4 channel o/p or networking if fitted. (Comms is used when data sent over a serial link to be traced on the chart without an I/O board.) If any modification is made, operation of the ENTER key will call a 'QUIT / CONTINUE' page, asking if the instrument is to be re-initialised to the new card configuration.
PASSWD	Enter new password	A new password up to 10 characters long can be entered using the numeric keyboard. Setting the password to a single 0 (zero) allows direct entry from the operator menu. Once the password has been confirmed by operation of the 'Enter' key, the operator is requested to enter it again (to ensure that it was correct the first time). If the second entry differs from the first, the message 'New Password Rejected' appears, and the recorder returns to the 'Instrument: Select a category' page.
KEYS	Operator key N	When the KEYS softkey in page 2 of the Operator menu is operated, the five softkeys can be used as event sources. The KEYS softkey in the Instrument Configuration menu allows the softkey labels and actions to be defined. The page scroll key is used to scroll through the five displays. On each page, the softkey legend can be entered and each softkey can be defined as being latching or non-latching by using the field scroll keys. The actions associated with each softkey are defined in the Event configuration (Section 4.6).
LANG'GE	ENGLISH / FRENCH / GERMAN	Sets all further displays into English / French / German.

4.2.1 INSTRUMENT PARAMETERS (Cont.)**PAGE 3 PARAMETERS**

REM CJ	Channel NN (DNN)	Allows one or more input channels to be defined (using the numeric keys) as remote CJ inputs. The input types, linearisations etc. must be entered as a part of channel configuration, using the same temperature units as those specified in the 'Units of' field described immediately below. To use a derived channel, the channel number must be assigned a 'D' prefix, using the \pm key.
	Units of	Allows °C, °F or Kelvin or Rankine to be selected for the remote CJ, using the field scroll keys.
	Enable/Disable	Allows the operator to disable the remote CJ channels.
LIN TAB	CONTENT	Allows entry of up to two linearisation tables, each of which can have up to 32 input/output pairs, either equally or non-equally spaced. The user can select which sets of points to apply to a particular input signal. A linear interpolation is carried out between pairs.
	TITLE	Allows a table title to be entered.
CYCLE	Cycle time	Allows the operator to force the recorder iteration rate to a value other than its normal one second.
	System error cycle time limit	When set to zero, no error is reported if the recorder cycle time exceeds the default (1 sec.) or user specified cycle time. If the error time limit is set to the default or user specified time, then a system error message is generated each time the cycle time exceeds the error limit time.
SYS ERR		Operation of this softkey causes any system errors to be displayed. Where appropriate, a CLEAR softkey is included on the bottom line. If more than one error message is active, the page scroll keys are used to access further pages.

PAGE 4 PARAMETERS

IDENT	Allows the operator to enter a unique, 20-character, instrument identifier for including in memory card logs (if the relevant option is fitted) and with networked instruments
-------	--

4.3 CHART CONFIGURATION

The chart configuration allows the following items to be set up:

1. Chart speed units (SPEED softkey). This allows the choice of mm/hr or inches/hour. This selection should be made before any new chart speed settings are made.
2. Chart speeds A and B (SPEED softkey). This allows two alternative speeds to be entered for selection from the Operator menu (section 3.2.2) or by job action (section 4.1.3). The available fixed speeds (table 4.3) are scrolled through using the field scroll keys.
3. A user-defined chart speed is enterable using the numeric keys. The available range is from 0 to 1500 mm/hr or 0 to 60 in/hr, according to the speed units chosen.
4. Logging intervals A and B (LOG INT softkey). This allows two alternative logging intervals to be entered for selection from the Operator menu or by job action. The logging interval defines how often log 1 is automatically printed on the chart. (0 = log 1 not automatically printed.)
5. Print modes A and B (MODE softkey). This allows two print modes to be defined for selection from the Operator Menu or by job action. The available print modes: Trace priority, Text priority and Text only are described below in section 4.3.2.
6. Interpolation (TRACES softkey). Allows interpolation to be switched on or off. Interpolation 'on' causes the printer to draw a horizontal line between normal dotting points, to smooth the trace at high chart speeds.
7. Adaptive recording (TRACES softkey). Allows adaptive recording to be switched on or off. Adaptive recording traces all signal variations even at low chart speeds.

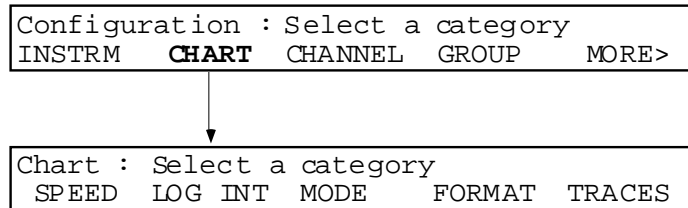

Figure 4.3 Chart configuration

As can be seen from the figure, entry is by operation of the CHART softkey in the top level configuration menu. In order to return to higher levels of menu, the Cancel, Enter or Home key is operated.

Note: For date format (Day/Month/Year or Month/day/year) selection see Instrument Configuration.

4.3.1 Chart parameters

Note: If the chart speed units are to be changed, this should be done before setting chart speeds. In particular, the 'user speed' is not converted so if, for example, a mm/hr chart speed value is entered and the units are subsequently changed to in/hr, the entered 'user speed' value is lost.

SPEED	Speed A (B)	Allows chart speed A (B) to be entered for selection by the operator or as a result of job action. Chart speeds are scrolled-through using the field scroll keys. The available chart speeds are listed in table 4.3.1 below.																										
	Units	Allows mm/hr or in/hr to be selected using the field scroll keys. See the note above.																										
	User speed	Allows entry of any speed up to 1500 mm/hr (60 in/hr) using the numeric keys. As stated in the note above, if this entry is made before the chart speed units are changed, the value is lost (i.e. set to zero).																										
<table border="1"> <tr> <td>mm/hr.</td> <td>Off</td> <td>5</td> <td>10</td> <td>20</td> <td>30</td> <td>60</td> <td>120</td> <td>300</td> <td>600</td> <td>1200</td> <td>1500</td> <td>User</td> </tr> <tr> <td>in/hr</td> <td>Off</td> <td>0.25</td> <td>0.5</td> <td>1</td> <td>2</td> <td>4</td> <td>5</td> <td>6</td> <td>10</td> <td>25</td> <td>50</td> <td>User</td> </tr> </table>			mm/hr.	Off	5	10	20	30	60	120	300	600	1200	1500	User	in/hr	Off	0.25	0.5	1	2	4	5	6	10	25	50	User
mm/hr.	Off	5	10	20	30	60	120	300	600	1200	1500	User																
in/hr	Off	0.25	0.5	1	2	4	5	6	10	25	50	User																
Table 4.3.1 Available chart speeds																												
LOG INT	Logging interval A (B)	Allows log 1 printing interval A (B) to be entered for selection by the operator or as a result of job action. Logging intervals (in hours and minutes up to 99 hrs, 99 minutes.) are entered using the numeric entry keys. An entry of 00:00 causes automatic printing of log 1 to be inhibited. (For Log 2, archive interval is set up as a part of the Memory Card configuration.)																										
MODE	Print mode A (B)	Allows print mode A (B) to be entered for selection by the operator or as a result of job action. The field scroll keys are used to scroll through the three available modes: Trace priority, Text priority, Text only (see section 4.3.2 for further details).																										
FORMAT	Scale format	Allows channel scales to be printed with: descriptor only, tag only or descriptor and tag.																										
TRACES	Interpolation	Use the field scroll keys to enable / disable interpolation																										
	Adaptive recording	Use the field scroll keys to enable / disable adaptive recording.																										

4.3.2 Print modes

The recorder can operate in one of three modes to print data on the chart:

TRACE PRIORITY

All message types can be printed, but the traces are not interrupted. All demand messages are queued until printed. If the queue overflows, 'Message lost' is printed on the chart.

TEXT PRIORITY

Demand messages are printed in overprint (i.e. traces are not interrupted) if the print queue is less than 70% full. Otherwise, message printing takes priority and the traces are broken. When logging, the trace is always broken. If the queue overflows, 'Message lost' is printed on the chart.

TEXT ONLY

All cyclic messages are inhibited. Only logs and demand messages are output. This mode is intended for report generation and alarm logging. If the print queue overflows, 'Message lost' is printed on the chart

4.4 CHANNEL / ALARM CONFIGURATION

Channel / alarm configuration is described in the following sub-sections: Range, Alarm, Zone, Trace, Ident. Each of these categories is accessible by softkey action from the Channel level 1 display.

In order to help new users, Section 2 gives step-by-step instructions to allow the complete configuration of a single input channel to be carried out, then copied to further channels.

4.4.1 Channel address allocation

Each I/O board has an address (*irrespective of its physical slot location*) allocated to it by a user-accessible rotary switch. Each address is associated with eight channels as shown in table 4.4.1.

If, for example, 8-channel boards with addresses 1 and 3 are fitted, but address 2 is not used, then channels 1 to 8 and 17 to 24 are available for measurement purposes but channels 9 to 16 are not. These channels can still be configured (if 'shutdown' as described in section 4.2.1 (CARDS)), if the missing board is later to be fitted.

Address	Chan N°s
0	Invalid
1	1 to 8
2	9 to 16
3	17 to 24
4	25 to 32
5	33 to 40
6	41 to 48
7	Relay only
8	Relay only
9	Relay only
A to F	Invalid

Table 4.4.1 Channel addressing

ADDRESSING RULES

1. Addresses 0 and A to F are not recognised by the I/O boards, and any data requested or sent is ignored.
2. 16-channel boards use two addresses, so the first address after a 16-channel board, must be left empty. Within this constraint, 16-channel boards can be allocated any address between 1 and 5.
3. 8-channel input boards can be allocated any address from 1 to 6 provided that the preceding address is not assigned to a 16-channel board.
4. Relay output boards can be allocated any valid address provided that the preceding address is not assigned to a 16-channel board.
5. As despatched from the factory, address 1 is at the topmost slot, and channel numbers increase from right to left when viewed from the rear of the recorder.

CAUTION

ALWAYS SWITCH THE RECORDER OFF, OR ISOLATE FROM LINE POWER BEFORE OPENING THE WRITING SYSTEM, AND ENSURE THAT THE PRINthead IS PARKED.

Open the recorder door and remove the card retainer (secured by screw 'A' in figure 4.4.1) to reveal the I/O boards.

The address switches are located on the front edges of the I/O boards.

The address is adjusted by inserting a small, preferably plastic, tool into the switch slot, and rotating the switch wiper to the required position.

Refit the card retainer, and with the recorder powered, go to Instrument Configuration and update the CARDS page(s) (section 4.2.1) to show the new address set-up.

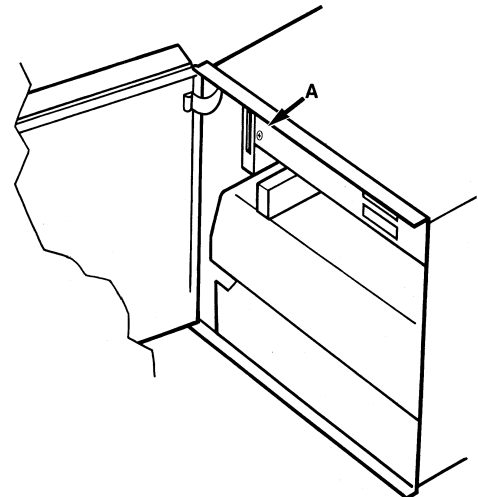

Figure 4.4.1 Card Access

4.4.2 Channel configuration: Range

INPUT CHANNELS

Operation of the CHANNEL softkey causes the level 1 channel configuration page to appear. Enter the required channel number using the numeric keys. Operation of the RANGE softkey now calls the first of the three Range pages. Four of the alternative input types, together with their subsequent pages are depicted in figure 4.4.2. The parameters on these pages tell the channel about the input signal which is going to be applied to it.

On page one, select input type and range of measurement. For thermocouples, select cold junction compensation type. For 'current' inputs, specify a shunt value. For 'digital' inputs, open and closed state labels (descriptors) can be entered. Go to page two before operating the 'Enter' key.

On page two, select a linearisation type to match the input type selected at page one. For a voltage or current input representing a temperature, enter a linearisation range. For signals requiring scaling before trace and display, enter scale limits to match the input range.

On page three, select decimal point position for the display, select a damping period and input break response.

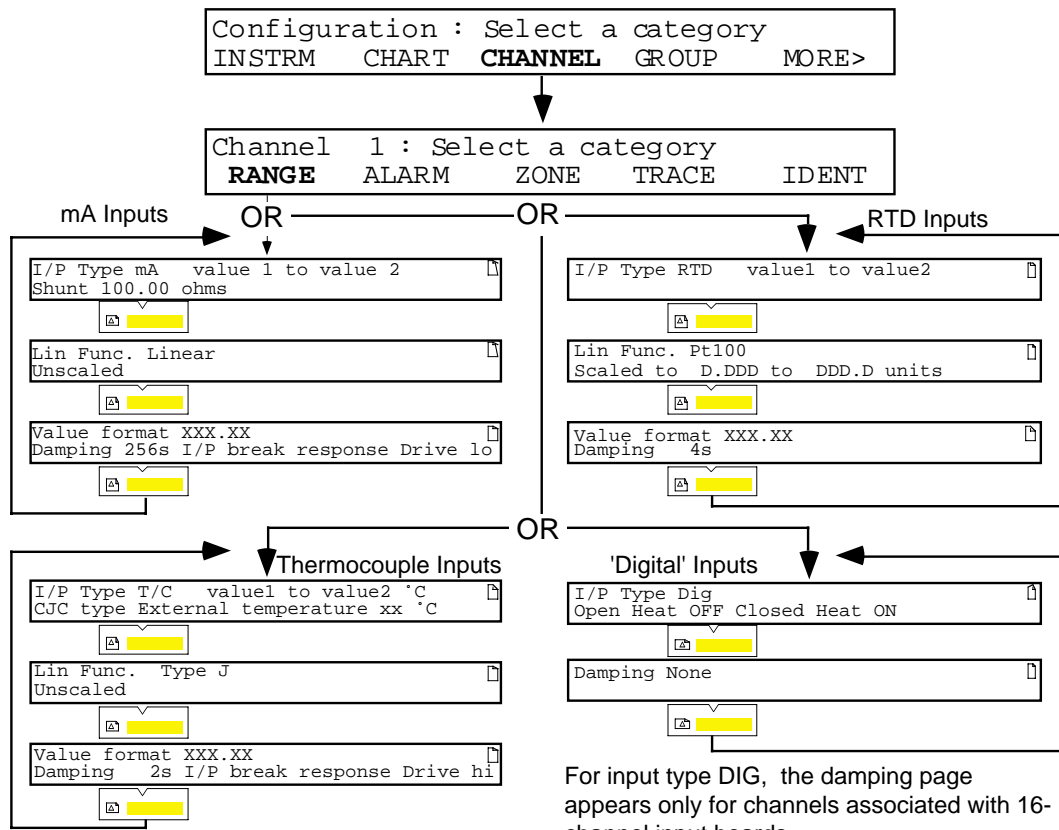

Figure 4.4.2a input channel configuration: Typical range pages

4.4.2 INPUT CHANNEL CONFIGURATION: RANGE (Cont.)**PAGE ONE PARAMETERS**

I/P type	Allows the required input type to be selected. The available types (scrolled by the field scroll keys) are as follows:
<hr/> <p>Note: A suitable linearisation function must be selected from page two before the 'Enter' key is operated. If this is not done, the message 'Invalid configuration' will appear.</p> <hr/>	
Off	The channel is switched off; no processing of channel input or alarms takes place.
T/C	Selects 'thermocouple' as the type of input.
mV	Selects mV as the type of input.
V	Selects Volts as the type of input
mA	Selects mA as the type of input
RTD	Selects resistance thermometer as the type of input. (Not 16-channel board)
Ohms	Selects Ohms as the type of input. (Not 16-channel board).
Dig	Selects digital (discrete) input (switch contact). Open input is accepted if the resistance across the input terminals is greater than 3000 Ohms. Closed input is accepted if the resistance across the input terminals is less than 500 Ohms. Contact closure inputs are not available on channels 1, 8 or 16 of the 16-channel dc input board (dig does not appear as a menu item for these channels.)
Comms	Must be selected if the host computer is to address the channel (applicable only to recorders fitted with the communications option).
Test	Allows a test sine or triangular waveform to be selected.
Value 1 (2)	Allows entry of the expected range of the input signal. Value 1 is the low end of the range; Value 2 the high end.
°C	For thermocouple and RTD inputs, the temperature units can be set to °C, °F, K (Kelvin) or Rankine (R) using the field scroll keys.
CJC type	Allows Internal, external or remote cold junction compensation to be applied by scrolling through the three types, using the field scroll keys. Applies only if input type is 'thermocouple'.
Internal	The recorder uses its integral cold junction for compensation.
External	Allows the temperature at which the external cold junction is maintained to be entered using the numeric keys. The temperature units for the cold junction are those set up as input units.
Remote	Selects 'Remote' to be used for cold junction compensation. The channel which is to measure the temperature to be used for this input card is defined as a part of the instrument configuration, as described in section 4.2.
Shunt	Allows a shunt value to be entered (using numeric keys) when mA is selected as input type. A 100 Ohm shunt gives 2 V at 20 mA; a 250 Ohm shunt gives 5 V at 20 mA. The value entered must match the shunt connected across the inputs.
Open (closed)	Allows two legends to be entered for 'digital' inputs, one for the open input case; the other for when the inputs are closed. These legends appear at the display as channel status.

The page down key is operated to call the second range page to the display:

Note: DEFAULT ALARMS. If the input type is changed to DIG, the alarm type defaults to OFF, Digital, Dwell 0 sec. If the input type is changed from DIG, the alarm type defaults to OFF, Absolute high, Setpoint 10.00.

4.4.2 INPUT CHANNEL CONFIGURATION: RANGE (Cont.)**PAGE TWO PARAMETERS**

Lin Func	<p>Allows an appropriate linearisation function to be defined for the input type selected at page one. The following linearisations can be scrolled through using the field scroll keys:</p> <p>Thermocouples: Types B, C, E, J, K, L, N, R, S, T, U, NiMoNiCo (note 3), Platinel II.</p> <p>Resistance thermometers: Pt100, Pt1000, Cu10, Ni100, Ni120</p> <p>Other functions: Linear, sqrt, $x^{3/2}$, $x^{5/2}$, User 1, User 2.</p>
Notes	<ol style="list-style-type: none"> 1. An appropriate linearisation function must be selected here, before the i/p type is 'Entered' at page one. If this is not done, the message 'Invalid Configuration' will appear. 2. The 16 channel dc input card supports a maximum of eight different linearisation functions, including 'linear'. 3. Previous versions of the recorder came with NiNiMo linearisation instead of NiMoNiCo.
Unscaled / Scaled to	<p>The field scroll keys are used to scroll between 'Unscaled' and 'Scaled to'.</p> <p><u>Unscaled:</u> The scale is identical with the range.</p> <p><u>Scaled to:</u> Used to allow entry of chart / displayed values, when the input value (page 1) and the chart/displayed values are to be different, as in the following example.</p> <p><u>Example:</u> An input from a transducer has a range of 0 to 5 V. It is required however that the displayed value is in %, where 0 V represents 0% and 5 V represents 100%. In such a case, a range would be set (in page 1) of 0 to 5, and a scale would be set here, in page 2, of 0 to 100.</p>
Units	<p>Allows a Units string to be entered using the keyboard / field scroll keys. The cursor (left and right arrow) keys are used to move from character to character. The Clear (C) key can be used to delete the existing or newly entered string, from cursor to the end of the line. (Use of the Cancel (X) key will cause all the changes so far made in pages one and two to be lost).</p>

The page down key is operated to call the third range page to the display.

PAGE THREE PARAMETERS

Value format	<p>Allows the required decimal point position to be chosen for display. The available positions (scrolled-through by the field scroll keys) are: X.XXXX, XX.XXX, XXX.XX, XXXX.X, XXXXX.</p>
Damping	<p>For the 16-channel dc input board, one of the following time constants (scrolled-through using the field scroll keys) can be applied to any input signal: None, 2, 4, 8, 16, 32, 64, 128 or 256 seconds.</p> <p>For the 8-channel universal input board, damping can be applied to all types of input, except 'dig' (Contact closure).</p>
I/P Break response	<p>Allows Drive hi(gh), Drive lo(w) (not 16-channel board) or None to be selected, using the field scroll keys. Drive hi causes the trace to move to full scale (span) if the input goes open circuit. Drive lo causes the trace to move to chart zero. If 'none' is selected, the trace will drift, responding to any voltages picked-up by the external wiring acting as an aerial.</p>

Operation of the Enter key causes all the changes made in pages one, two and three to be sent to the recorder data base. Operation of the page down key re-calls page one to the display. A further operation of the 'Enter' key, or operation of the cancel key returns the level 1 Channel configuration page to the display.

4.4.2 CHANNEL CONFIGURATION : RANGE (Cont.)

OUTPUT CHANNELS

Operation of the CHANNEL softkey causes the level 1 channel configuration page to appear. Operation of the RANGE softkey from this page calls the first of the Range pages to appear. Alternative output types, together with their subsequent pages are depicted in figure 4.4.2b. The parameters on these pages are described in the tables below.

On page one, select output type, range of measurement and source of input. For input or derived channel sources, page two allows offset and span values to be entered. For constant source, this page does not appear.

On page three, select decimal point position for the display and error response.

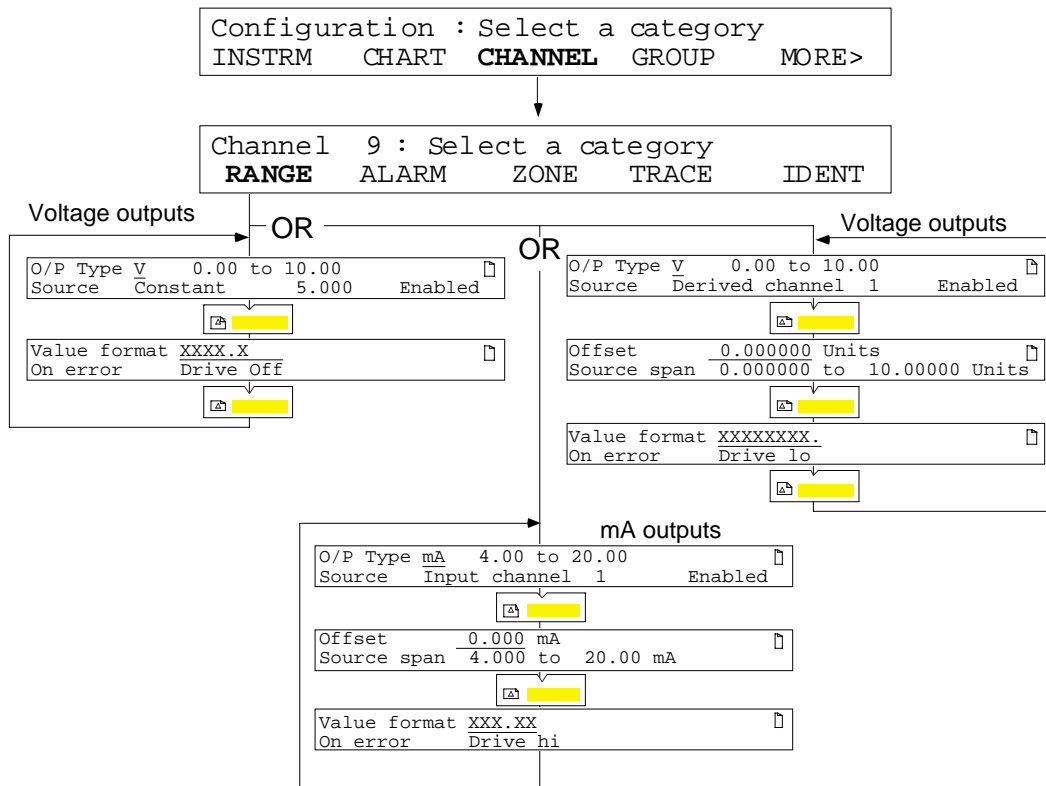

Figure 4.4.2b Output channel configuration: Typical range pages

4.4.2 OUTPUT CHANNEL CONFIGURATION (Cont.)

PAGE 1 PARAMETERS

O/P type	Off	Allows the required output type to be selected as Off, V or mA Channel output goes to 0mA at Io and C terminals, and approximately -1 Volt across Vo and C terminals.
	V	Sets the channel to apply a voltage signal across Vo and C terminals. Allows a span of up to 10V to be entered. Io is set to its Off state.
	mA	Sets the channel to source current at the Io and C terminals. Allows a span of up to 25mA to be entered. Vo is set to its Off state.
Source	Input channel N	Use numeric keys to enter channel number
	Derived channel N	If maths pack option fitted, use numeric keys to enter derived channel number.
	Constant	Allows a constant to be entered using the numeric keys. The output range available is -15 to +115% of the span set in the top line of the page, provided that this does not exceed the absolute maximum figures given in the technical specification at Annex A.
Enabled		Scrollable through 'Disabled' and 'Enabled'. When disabled to outputs are set to their off states.

PAGE 2 PARAMETERS

Note: this page does not appear when input source 'constant' is selected in page 1.

Offset	Allows an adjustment to be made to match the recorder output with external equipment.
Source span	Initially shows the source channel's span, but can be edited using the numeric keypad.

PAGE 3 PARAMETERS

Value format	Allows the required decimal point position to be chosen. For source = constant, the available positions (scrolled-through by the field scroll keys) are: X.XXXX, XX.XXX, XXX.XX, XXXX.X, XXXXX. For source = input or derived, additional formats are available as follows: XXXXXXXX, XXXXXXXX.X, XXXXXXXX.XX, XXXXX.XXX, XXXX.XXXX, XXX.XXXXX, XX.XXXXXX, scientific, time, date, elapsed. See section 5.3.1 for details.	
On error	lo	Determines what the output signal does if the source channel fails or if the recorder internal communications stop. Signal goes to 'zero' - 15% span.
	hi	Signal goes to span + 15% span
Off	Switches output off as defined in 'O/P type' in 'Page 1 parameters' above.	

4.4.3 Channel configuration: Alarms

Note: In the following diagrams, the measured value increases from left to right.

Up to four alarms can be configured for each channel. The available alarm types are: Absolute high, Absolute low, Rate-of-change rise, Rate-of-change fall, Deviation in, Deviation out, Digital active-open, Digital active-closed.

Digital alarms can be selected only for channels defined as 'I/P Type Dig' in Range Configuration above. Channels defined as Dig can have only digital alarms.

For absolute and deviation types, a hysteresis value can be configured to prevent continuous triggering of the alarm, should the process variable value 'hover' at or near the setpoint (or threshold). For all types of alarm, a 'Dwell' period can be configured, to delay the alarm becoming active after it has been triggered. If the value goes out of alarm during the dwell time, then the alarm is ignored.

Alarms can be used to trigger a wide range of jobs (Section 4.1.3) including the operating of output relays.

ALARM ACTION

The four types of alarm action are as follows:

Off	The alarm is disabled.
Trigger	Once active, the alarm stays active until the alarm source returns to a non-alarm state. Any continuous jobs (e.g. change print mode) will remain active for the duration of the alarm state. Trigger alarms are not annunciated in any way (e.g. no bell symbol appears at the display; no messages are printed on the chart) and do not appear in history lists.
Latching	Once active, the alarm stays active until it is both acknowledged AND the alarm source has returned to a non-alarm state. Any continuous jobs (e.g. change chart speed) remain active until the source returns to a non-active state (whether or not the alarm has been acknowledged).
Non-latching	Once active, the alarm stays active until the alarm source returns to a non-alarm state. Any continuous jobs (e.g. change print mode) will remain active for the duration of the alarm state.

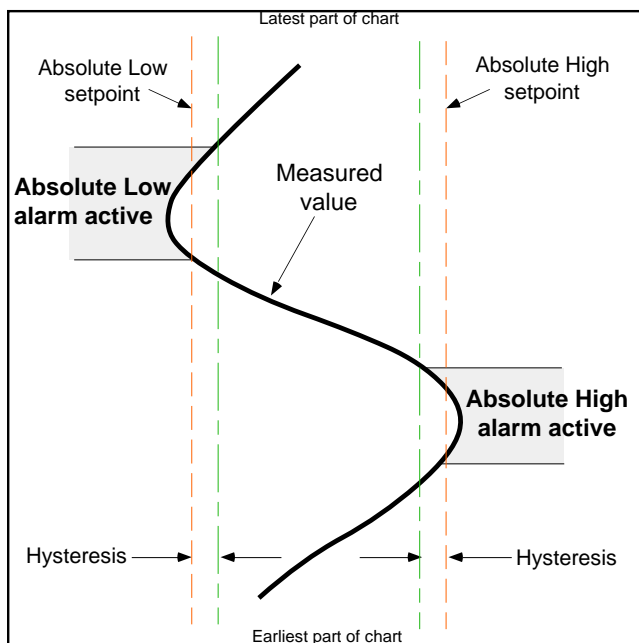

Figure 4.4.3a Absolute alarm definitions

An absolute high alarm becomes active when its setpoint value is exceeded, and remains active until the measured value falls below the value ($setpoint - hysteresis$).

An absolute low alarm becomes active when the measured value falls below the setpoint, and remains active until the measured value rises above the value ($setpoint + hysteresis$).

4.4.3 ALARM TYPES (Cont.)

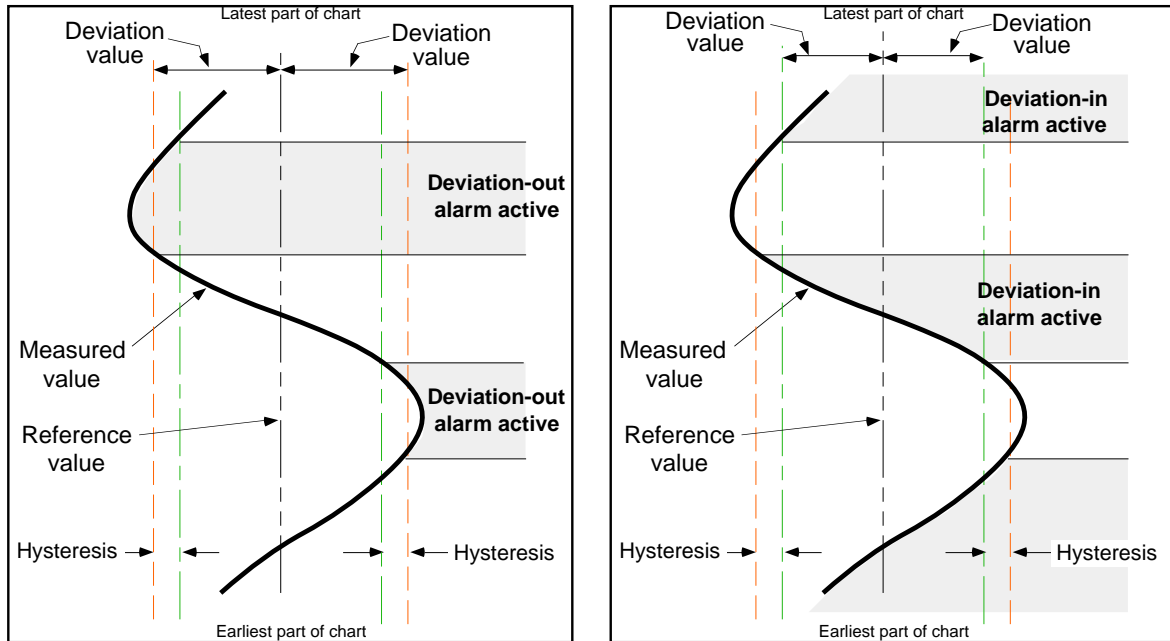

Figure 4.4.3b Deviation alarm definitions

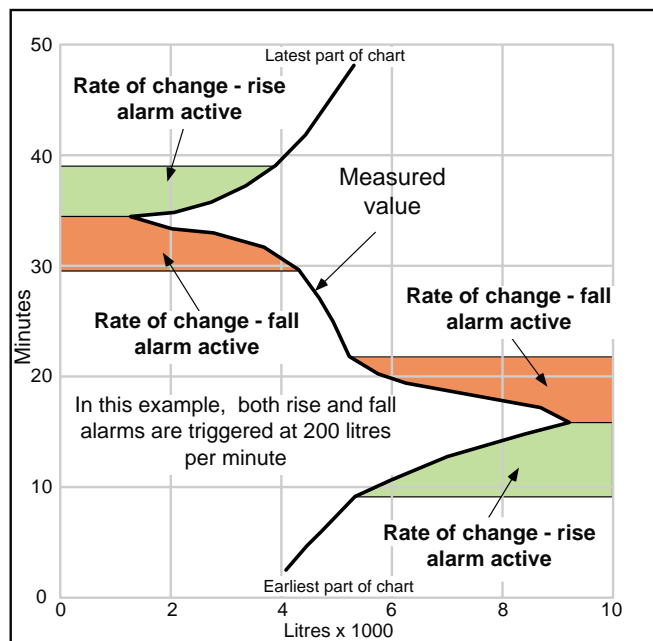

Figure 4.4.3c Rate-of-change alarm definitions

With Rate-of-change alarms, a value (200 litres in the above sketch), a time period (one minute above), and an averaging period have to be configured. The alarm is triggered if the measured value changes by more than the configured value in less than the configured period (more than 200 litres per minute in the above example). The averaging period is used to change the sensitivity of the alarm, such that noise spikes on, or normal oscillations in the input signal do not trigger false alarms.

4.4.3 ALARM TYPES (Cont.)

DIGITAL (DISCRETE) ALARMS

These alarms are triggered by contact closures or openings as defined during configuration. The relevant channel must be configured as 'Input Type Dig' in its Range configuration.

Note: Contacts closed is defined as a resistance of less than 500Ω across the input; Contacts open is defined as a resistance of more than 3000Ω across the input.

Figure 4.4.3d shows typical display pages for the four types of alarm. Select alarm 1 to 4 for the channel, using the field scroll keys

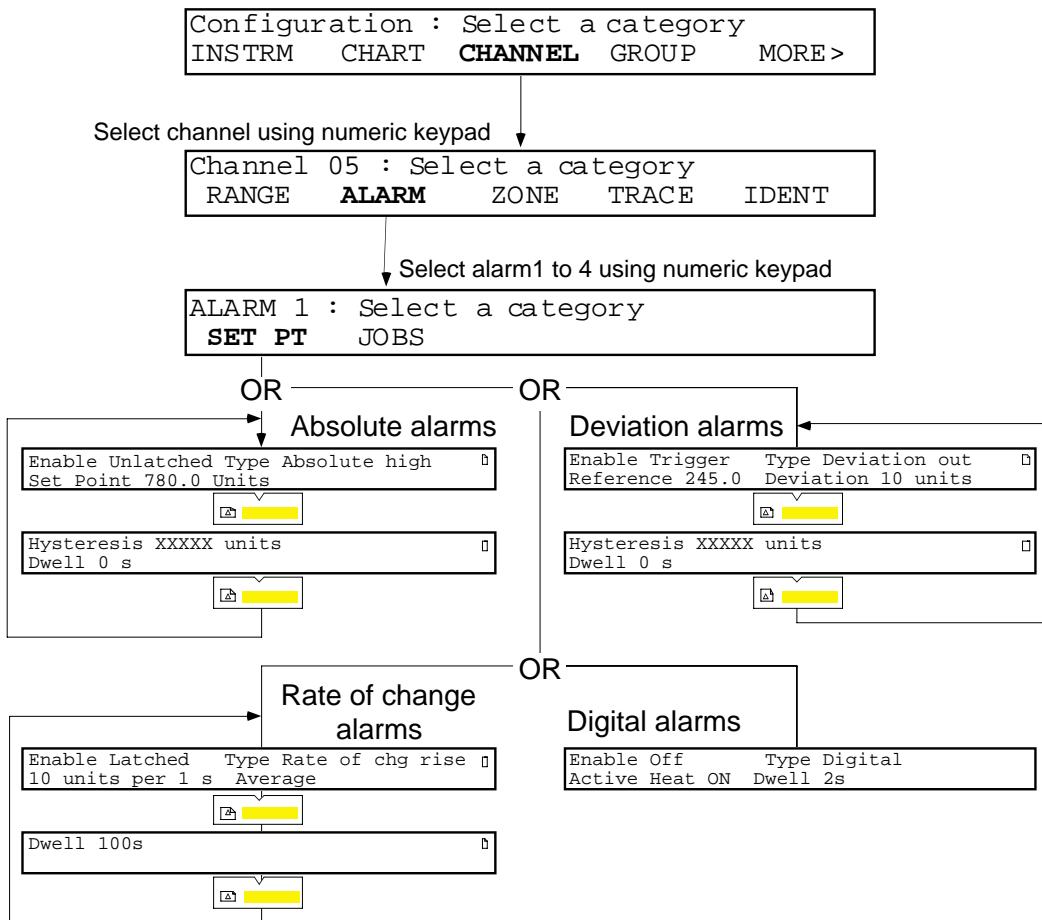

Figure 4.4.3d Channel configuration: Typical alarm pages

4.4.3 CHANNEL CONFIGURATION: ALARMS (Cont.)**SET PT SOFTKEY PAGE ONE PARAMETERS**

Enable		Allows the following Enable functions to be scrolled-through using the field scroll keys.
	Off	All alarm action inhibited
	Trigger	Initiates Jobs but does not annunciate. Suitable for remote control purposes such as updating the clock, resetting totalisers etc.
	Unlatched	Alarm display and job actions are active as long as the alarm is active.
	Latched	Alarm display is active until the alarm returns to a non-active state, and the alarm has been acknowledged. Continuous job actions continue until the alarm returns to its non-alarm state, whether the alarm is acknowledged or not.
Type		Allows the different types of alarm to be scrolled through using the field scroll keys: Absolute high / low; Rate-of-change rise / fall; Deviation in / out; Digital.
Absolute	Set Point	For absolute alarms only. This is the trigger level entered using the numeric keys, at which the alarm becomes active.
Deviation	Reference	For deviation alarms only. This sets a central value about which the Deviation value (see immediately below) is to operate. Entered using the numeric keys.
	Deviation	For deviation alarms only. This sets a range, either side of the reference value, inside which a 'deviation in' alarm is active or outside which a 'deviation out' alarm is active. Entered using the numeric keys.
Rate	Value	For rate-of-change alarms only, allows a value (D) to be entered using the numeric keys. If the change in the channel value (ΔPV) over the time period specified (T) (see immediately below) is greater than D, the alarm becomes active. (I.E. if $\Delta PV/T > D$ the alarm is active.)
	Time	Allows a time period (T) to be entered (using the field scroll keys) for use with the above Value. Scrollable values are: 1, 10, 30 and 60 seconds, and 10, 30 and 60 minutes.
	Average	Allows averaging periods of 1 to 9 seconds to be entered using the numeric keys. This allows the sensitivity of the rate-of-change alarms to be varied.
Digital	Active	Scrollable between the Open state and Closed state text strings as entered in page one of Range configuration (see section 4.4.2 above). If set to the open state, then the alarm is active with a high resistance input. If set to the closed state the alarm is active with a low resistance input.
	Dwell	Allows initiation of alarm action to be delayed by up to 2048 seconds after the alarm is detected. If the channel goes out of alarm within this period, the alarm is ignored.

SET PT SOFTKEY PAGE 2 PARAMETERS

Hysteresis	Allows 'deadband' areas to be entered (using numeric keys), for absolute and deviation alarms, to stop 'twitching' if the channel value is hovering around the set-point.
Dwell	Allows initiation of alarm actions to be delayed for up to 2048 seconds after the alarm is detected. If the channel goes out of alarm within the dwell period, the alarm is ignored.

4.4.3 CHANNEL CONFIGURATION: ALARMS (Cont.)

JOBS SOFTKEY

As previously stated, each channel may have up to two jobs allocated to it (see section 4.1.3). Figure 4.4.3e shows some typical job pages. The job number is selected using page scroll keys.

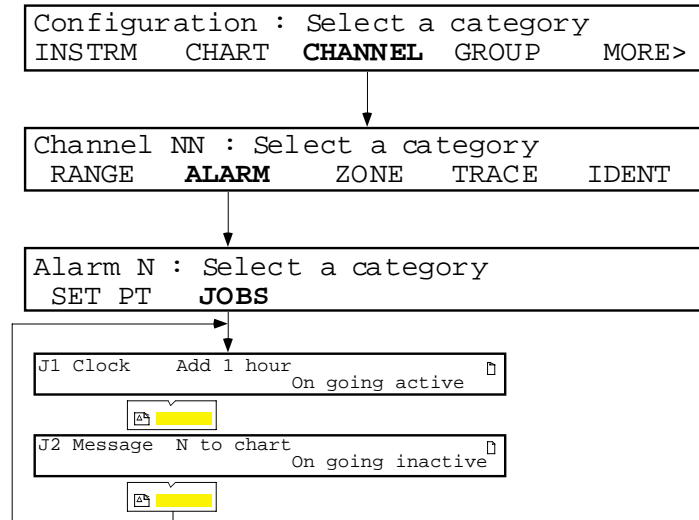

Figure 4.4.3e Typical job pages

JOB PARAMETERS

Type	Allows a job category to be selected using the field scroll keys. Categories are: No action, Chart, Trace, Alarm, Message, Logging, Derived, Timer, Counter, Totaliser, Relay, Clock, assuming the relevant options are fitted.
Action	The actions that can be scrolled through (using the field scroll keys), depend on the category selected - see section 4.1.3. For channel dependent jobs (e.g. 'Trace colour B whilst in alarm') the channel number must be entered using the numeric keypad, otherwise the action will take place on channel 1.
Trigger	This field allows the trigger types to be scrolled-through using the field scroll keys. The types are: On going active; On going inactive; On acknowledgement; While active; While inactive, While unacknowledged, depending on type.

4.4.4 Channel configuration: Zone

Zone configuration sets up spans, zones and scales to allow the location of the trace on the chart to be defined. Figure 4.4.4 shows the relevant display pages.

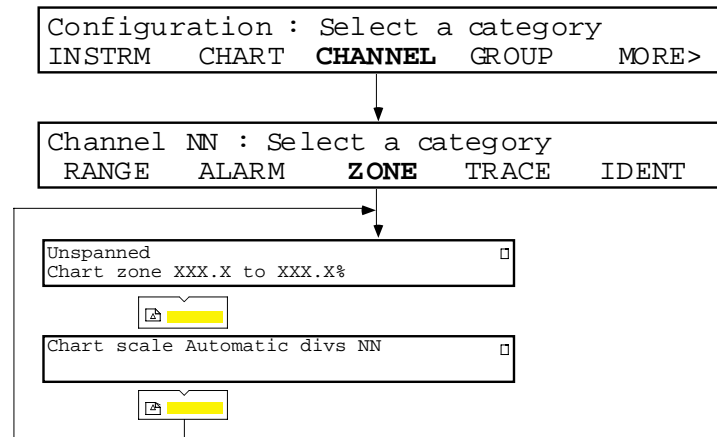

Figure 4.4.4 Channel configuration: Zone

ZONE PARAMETERS

Unspanned /Chart span	<p>Unspanned: Used when chart span is the same as the range / scale. Field scroll keys are used to scroll to 'Chart span'.</p> <p>Chart span: Allows a chart zero and full scale to be entered that is different from the input zero and full scale. For example, a range of 100 to 250 °C may be traced on the chart out of an input range of say, 0 to 800 °C, thus allowing an area of particular interest to be enlarged on the chart.</p>
Zone	Allows the printing area of the chart to be defined in percentage terms. In this way, a particular trace can be restricted to the right half of the chart to avoid being over-printed by columnar logs, or restricted to a part of the chart which is clear of other traces.
Chart scale	Allows the user to define the format of the scale.
Automatic divs	Defining automatic divisions 1 to 10 (numeric entry), allows the user to choose how many divisions of the scale are printed on the chart. For example selecting '1', causes 'zero' and full scale values only to be printed: Selecting '4', causes 0, 25%, 50%, 75 and 100% of the span to be printed.
Customised number N	Causes one of the four (selected by numeric entry keys) customised scales set up in the instrument configuration (section 4.2.1 (SCALES)) to be used by this channel.
Off	Inhibits scale printing for this channel

4.4.5 Channel configuration: Trace

Trace configuration allows the channel trace on the chart to be switched on or off, line thickening to be enabled/disabled and two alternative trace colours for the channel to be defined for selection by job action. Figure 4.4.5 shows the relevant page. For interpolation and adaptive recording on/off see Chart configuration - section 4.3.

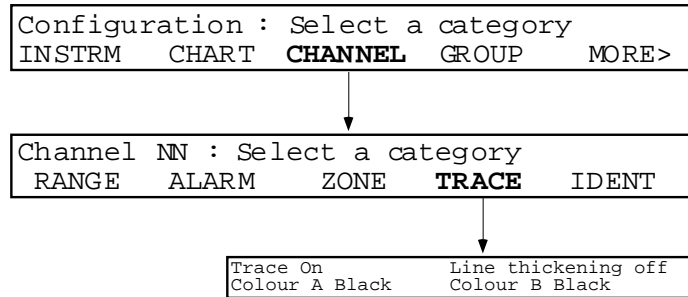

Figure 4.4.5 Channel configuration: Trace

Trace	Allows the channel trace to be permanently ON, permanently OFF, or conditionally on or off as required by a 'job.' The field scroll keys are used to scroll through these choices.
Line thickening	Allows line thickening to be switched on or off. Line thickening produces an extra wide trace on the chart to aid long-distance viewing.
Colour A (B)	The field scroll keys are used to scroll through the available colours for the channel trace. Colour B is selected by job action. Available colours are: red, brown, green, violet, blue and black.

DEFAULT CHANNEL COLOURS

Colours A and B for each channel are factory pre-set according to channel number. If no changes are made by the user, then the channels will print out in these colours. For each channel, default colours A and B are the same.

Table 4.4.5 shows the default colours for both measuring channels and derived (maths) channels if applicable.

Channel numbers	Default colours A/B
1 7 13 19	Red
2 8 14 20	Brown
3 9 15 21	Green
4 10 16 22	Violet
5 11 17 23	Blue
6 12 18 24	Black

Table 4.4.5 Channel default colours

4.4.6 Channel configuration: Ident

Ident configuration allows channel descriptors (17 characters maximum), and tags (7 characters maximum) to be entered using the cursor, scroll up and scroll down softkeys. The descriptor is entered at page one; the tag at page two.

The group configuration described below (Section 4.5) defines whether the descriptor or the tag is included in the PV display and in logs.

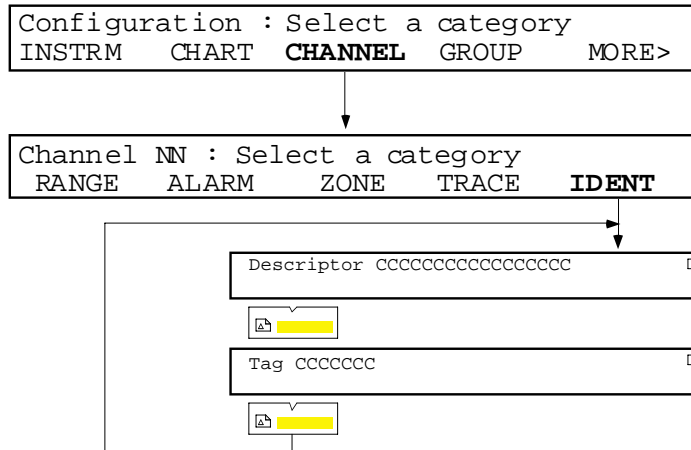

Figure 4.4.6 Channel configuration: Ident

4.5 GROUP CONFIGURATION

There are six groups to which process variables can be assigned. One group (Default name 'Everything') contains all configured Channels, totalisers etc. Though its title and the format in which its contents are displayed can be edited by the user, the contents of this group cannot be changed.

The remaining groups ('Empty 1' to Empty 5') can be fully configured as to content, title and format.

The selection of which group's contents is to be displayed during normal operation is made at the DISPLAY page of the Operator menu (section 3.2.1).

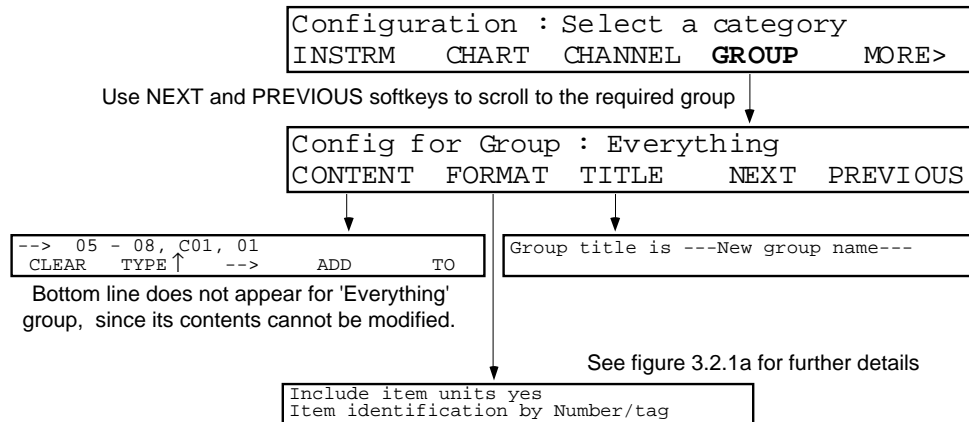

Figure 4.5 Group configuration

4.5.1 Group parameters

CONTENT (Note 5 below)	CLEAR TYPE↑	Deletes the cursor item from the group contents. Operation of this key scrolls through the types of PV which can be part of a group i.e. D (Derived channel), T (Totaliser), C (counter) and measuring channel (no prefix).
	ADD	Operation of this key causes a new entry (01) to be made. The numeric keys are used to enter the required number. The initial entry is a measuring channel. To change the entry to a derived channel, totaliser or counter, the TYPE↑ softkey is used.
	TO	This key allows a range of inputs to be entered. For example, the keystrokes given below would enter measuring channels 9 to 24.
		<p>Add 9 To 2 4 Enter</p>
FORMAT	Item identification by	Allows 'Number only', 'Number / Tag', or 'Number / Descriptor' to be scrolled-through using the field scroll keys. This defines how the group channels are identified in the logs, and at the display. For tag and descriptor entry, see section 4.4.6 (Channel configuration: Ident) above.
	Include item units	Allows the channel units string to be added to the PV identification. For Units entry, see section 4.4.2 (Channel configuration: Range) above.
TITLE	Group title is	Allows a title of up to 20 characters to be entered for the currently selected group using the Clear, cursor and field scroll keys.
NEXT / PREVIOUS		Allows the groups to be scrolled through.

4.5.1 GROUP PARAMETERS (Cont.)

Notes:

1. The TO key can be used to toggle between 'from' and 'to' range limits.
2. Group items are scrolled-through in the order in which they are entered. To insert an item, the cursor is positioned below the item immediately to the left of where the new item is to appear, and the ADD softkey operated as usual. The new item is inserted to the right of the cursor.
3. A 'single' item can be changed to a range item by positioning the cursor below it and operating the TO key.
4. Multiple entries are allowed. This can be used for example, to ensure that a particular derived channel (e.g. Group Average) always appears at the bottom line of the display (in 2-line mode), by entering the derived channel as every other item in the group.
5. The 'Everything' group contents cannot be changed, so the lower line of the CONTENT page is blank.

4.6 INTERNAL EVENT CONFIGURATION

12 internal events are configurable, and each event allows up to two jobs to be initiated as the result of single source or as combinations of sources as described below. Source types include both channel alarms and system errors.

It should be noted that, although only two sources can be combined for any one event, events themselves can be sources for other events, allowing multiple AND / OR functions to be carried out.

Example

The buzzer is to be sounded if

- a) Totaliser 1 is in alarm OR
- b) Channel 3 is in alarm OR
- c) Channel 5 is in alarm.

To achieve this, Event 1, say, can OR Channel 3 in alarm and Channel 5 in alarm sources. Event 2 can then OR Event 1 and 'Totaliser 1 in alarm' sources to sound the buzzer if any of the three sources goes active.

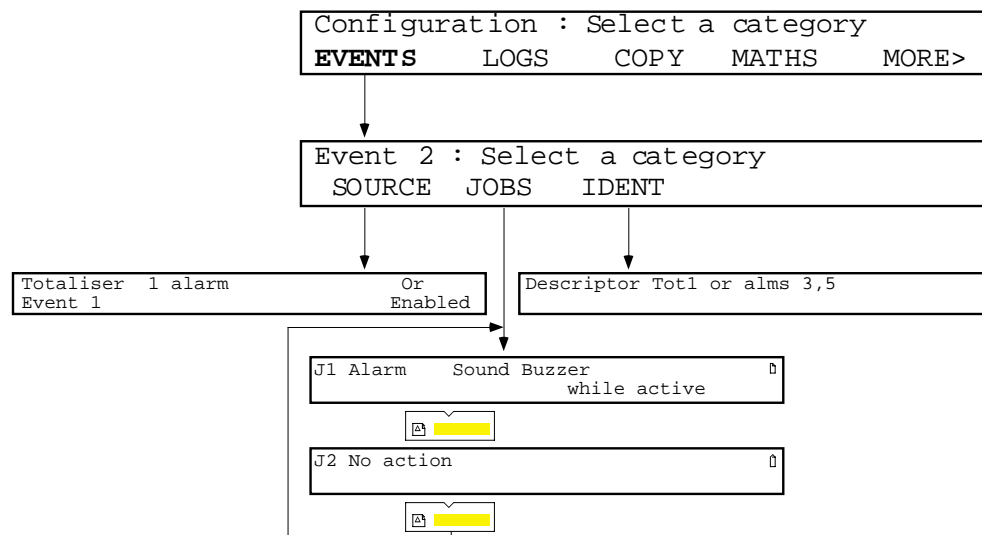

Figure 4.6 Event configuration

4.6 INTERNAL EVENT CONFIGURATION (Cont.)

4.6.1 Event parameters

SOURCE	Allows the event sources to be scrolled through using the Field Scroll keys. Each source can be active on its own or AND'ed or OR'd with another. Events can also be enabled or disabled. The event sources available, if all options are fitted, are:
System error	Active if any of the following instrument alarms are active: Writing system failure, Battery low, Clock hardware failure, Input channel failure, Invalid remote cold junction temperature, EEPROM failure, battery-backed RAM failure, cycle time exceeded.
Writing system failure	Active if a failure in the chart drive is detected.
Battery low	Active when the RAM battery voltage drops below a safe voltage.
Clock h/w failure	Active if the clock circuit fails.
Invalid remote cj temp	Active if a failure in the remote CJ sensing circuit is detected.
Power up	Triggers at initialisation.
Event	Allows one or more other events to be used as sources.
Totaliser alarm	Active if a specified totaliser's alarm is active
Group totaliser alarm	Active if any totaliser alarm is active in a specified group.
Counter alarm	Active if a specified counter's alarm is active
Group counter alarm	Active if any counter alarm is active in a specified group.
Timer output	Allows one or more timers to be defined as event sources.
DV partial failure	Active when one or more (but not all) inputs to a group maths function (e.g. Continuous Max) fails.
Mem. card battery low	The battery in the data card should be replaced as soon as possible
Mem. card battery flat	The battery is exhausted, and data will be lost when card is removed.
Mem. card full	Active when the memory card is full.
Mem. card NN% full	Active when the card is a configurable percentage full. See memory card manual.
Mem. card fitted	Active whilst a memory card is fitted.
Replaying file	Active during replay of a file from the memory card.
Manual key	The operator soft keys can act as event sources. The field scroll keys are used to scroll through the available softkeys.
Channel alarm	Allows an alarm on a specific channel to be used as an event input.
Channel alarm on group	Allows a group to be specified (field scroll). Any active alarm within this group will then act as an event source.
Unack'ed group alarm	Allows any channel alarm in a specified group to act as an event source until the alarm is acknowledged.
Input channel failure	Active if a failure in a specified input channel is detected.
JOBS	Type
	Allows a job category to be selected using the field scroll keys. Categories are: No action, Chart, Trace, Alarm, Message, Logging, Derived, Timer, Counter, Totaliser, Memory, Relay, Clock and M Card, assuming the relevant options are fitted.
	Action
	The actions that can be scrolled through (using the field scroll keys), depend on the category selected - see section 4.1.3
	Trigger
	This field allows the trigger types to be scrolled-through using the field scroll keys. The types are: On going active; On going inactive; On acknowledgement; While active; While inactive; While unacknowledged.
IDENT	Allows a 20-character descriptor to be entered for the event.

4.7 LOG CONFIGURATION

Allows a specific Group to be associated with each of the six available logs, and log destination (chart or memory card) to be defined. Logs are initiated by operator action, by job or automatically at a fixed time period. See section 4.1.4 of this manual, and the Memory Card manual for details.

Log text on the chart is in black, except for items in alarm which are printed in red.

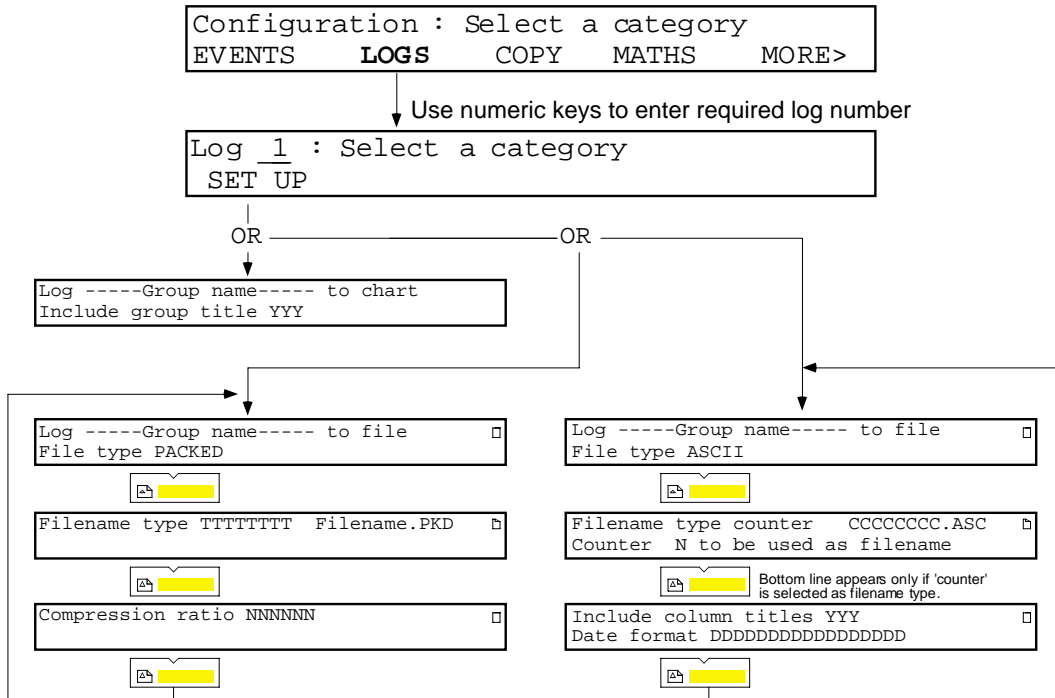

Figure 4.7 Log configuration pages

4.7.1 Log parameters

Group name	The field scroll keys are used to scroll through the groups.
To chart	The group is logged to chart.
Include group title	The field scroll keys are used to scroll through 'yes' and 'no', to select whether the group name is to be included in the log.
To file	If the data archiving option is fitted, the field scroll keys are used to scroll through PACKED or ASCII as log type. If data logging option fitted, only ASCII is available. If neither option is fitted, the 'to file' menu item does not appear and the 'to chart' item is not editable.
	For full details of the PACKED and ASCII parameters refer to the Memory Card manual.
PACKED	<u>Filename type.</u> Use the field scroll keys to scroll through 'text', hourly, daily or 'counter'.
	<u>Compression ratio.</u> Use the field scroll keys to scroll between 'Normal' or 'High'.
ASCII	<u>Filename type.</u> Use the field scroll keys to scroll through 'text', hourly, daily or 'counter'.
	<u>Include column titles</u> Use the field scroll keys to scroll between 'Yes' or 'No'.
	<u>Date format</u> Use the field scroll keys to scroll through 'Spreadsheet', 'Integer' or DD/MM/YY,HH:MM:SS.

4.8 COPY CONFIGURATION

This facility allows the copying of

- Measuring channel range and zone information,
- Alarm configuration, including jobs,
- Derived channel function and zone information, if the maths pack option is fitted.

Once the relevant sources have been selected, operation of the ENTER key initiates the copy process. During copying, a 'Please Wait' message is displayed. When copying is complete, the display returns to the previous channel, alarm or maths copy page.

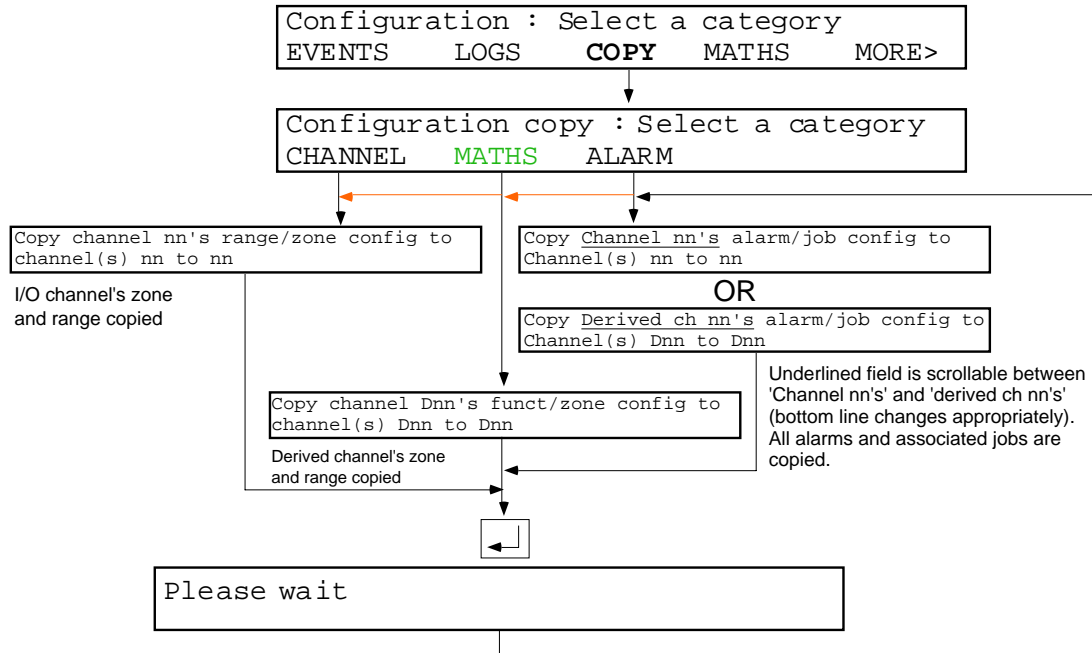

Figure 4.8 Copy configuration

4.8.1 Rules for copying

- When copying alarm configuration, I/O channels can be copied only to other I/O channels, and derived channels can be copied only to other derived channels. The bottom line of the display always repeats the selection made in the top line.
- If, during copying of range/zone, an input type is to be changed to digital the alarm type defaults to: OFF, Digital, Dwell 0 sec. If the input type is to be changed from digital to analogue, the alarm type defaults to: OFF, Absolute high, Setpoint 10.00.
- If an attempt is made to copy an alarm / job configuration, where the source and destination types are different (i.e. one digital and the other analogue), the copy will not be carried out, in order to avoid conflict between I/O type and alarm type.
- 16-channel board channels will not accept RTD or Ohms as input type; 'dig' as input type to channels 1, 8 or 16; input break drive lo(w).
- When copying 'dig' inputs from 8-channel boards to 16-channel boards, the damping is set to 'none'. When copying dig inputs from 16-channel boards to 8-channel boards, the copy is aborted if the damping is not set to 'none'.

4.9 OPTIONS CONFIGURATION

The maths pack, totaliser, counter and timer options are described in section 5 of this manual.

The Communications and Memory Card options are described in separate manuals supplied with the options

4.10 TRANSFER CONFIGURATION

Caution

This function can be used to transfer a configuration to another recorder. The existing configuration of the destination recorder is overwritten. Ensure that the transfer is carried out in the correct direction (from save to restore) to avoid overwriting the intended source recorder's configuration.

This feature allows the transfer of configuration between recorders, or between a recorder and a host computer, using the nine-way connector located above and to the right of the chart. Section 1.6 shows wiring details.

The configuration transfer connections are designed for TTL (0 to 5 V) signals. A RS232 converter may be required with some host computers, to change the signals to 12 Volts.

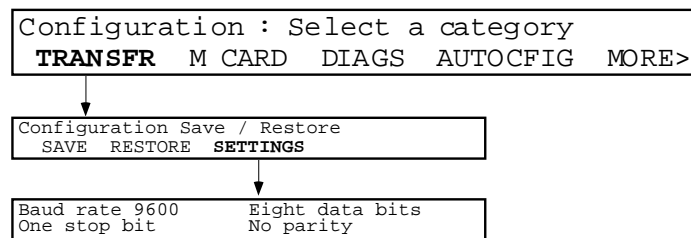

Figure 4.10 Configuration-transfer configuration

4.10.1 Transfer parameters

TRANSFER	Calls the configuration transfer page to the display. Before initiating transfer, ensure that a suitable cable is fitted between the recorder and the other device. See figures 1.6a/b
SAVE *	Initiates an XMODEM transfer of the recorder configuration via the 9-way D-type port located beside the chart illumination tube on the inside of the door. This can be used to copy configuration to another 'destination' recorder (previously set to RESTORE), or to store the recorder's configuration in any device capable of XMODEM file transfer.
RESTORE*	Allows a configuration to be loaded from a second recorder (set to SAVE) or from a PC or other configuration terminal.
SETTINGS	Allows the field scroll keys to be used to set the Baud rate to 19,200, 9,600, 4,800, 2,400, 2000, 1800, 1,200, 600, 300, 150, 134.5, 110 or 75 (must be the same at both devices). The other settings are fixed, as depicted in figure 4.10 above.

* A PC configuration tool is available from the recorder manufacturer.

Note: Any adjustments made in the 'Adjust' section of configuration (section 4.14 of this manual) are lost during configuration transfer.

4.11 DIAGNOSTICS

As shown in figure 4.11, operation of the DIAGS softkey calls the first of the diagnostics pages to the display. The following notes are intended to clarify the information contained in the figure.

4.11.1 SBC

This softkey allows the operator to view details of the SBC.

4.11.2 Board

Operation of this softkey calls board information for the board at address 1 to the display. The information is: Board type, Serial number and software version number. Board information for other addresses can be accessed by use of the page scroll key.

4.11.3 Pens

Operation of this softkey causes the printhead to print lines of TgTg...TgTg across the width of the chart, starting with the violet pen. Other pens are selected for test by softkey.

4.11.4 Relays

Operation of this softkey causes a display of relay status for the relay board (if any fitted) with the lowest address. Status is shown as E (Not in alarm state) or D (In alarm state). Relays can be toggled between E (Energised) and D (De-energised) using the page keys. Other relay boards can be accessed using the page-scroll keys.

4.11.5 Output

Allows two analogue output channels to be exercised so that their actual outputs can be compared with their required outputs. All other channels are set to their 'on error' status (section 4.4.2 - output channels).

Output	n	±DDDDD.DD	UUUUU	±dd.dd	uu
for card	N	n	±DDDDD.DD	UUUUU	±dd.dd uu

N	Slot number	Initially, the lowest slot number containing an analogue output (AO) board. When all the channels of this board have been scrolled through (Page keys) the next slot with an AO board fitted will appear. When all AO channels have been scrolled through, the first AO board is returned to.
n	Channel number	Pairs of channels are scrolled through using the Page keys.
±DDDDD.DD	Control value	User entered control value in engineering (UUUUU) units.
UUUUU	Engineering units	The engineering units in which the channel is configured.
±dd.dd	Actual value	The output value in Volts or mA (uu) as configured.
uu	Actual units	The output type (V or mA) as configured.

The only user accessible fields are the ±DDDDD.DD fields which can be accessed using the cursor keys.

Notes:

- 1 All AO channels except the two on display are set to their 'On error' value
 - 2 The message 'No analogue outputs configured' appears if no analogue output channels have been configured.
-

4.11 DIAGNOSTICS (CONT.)

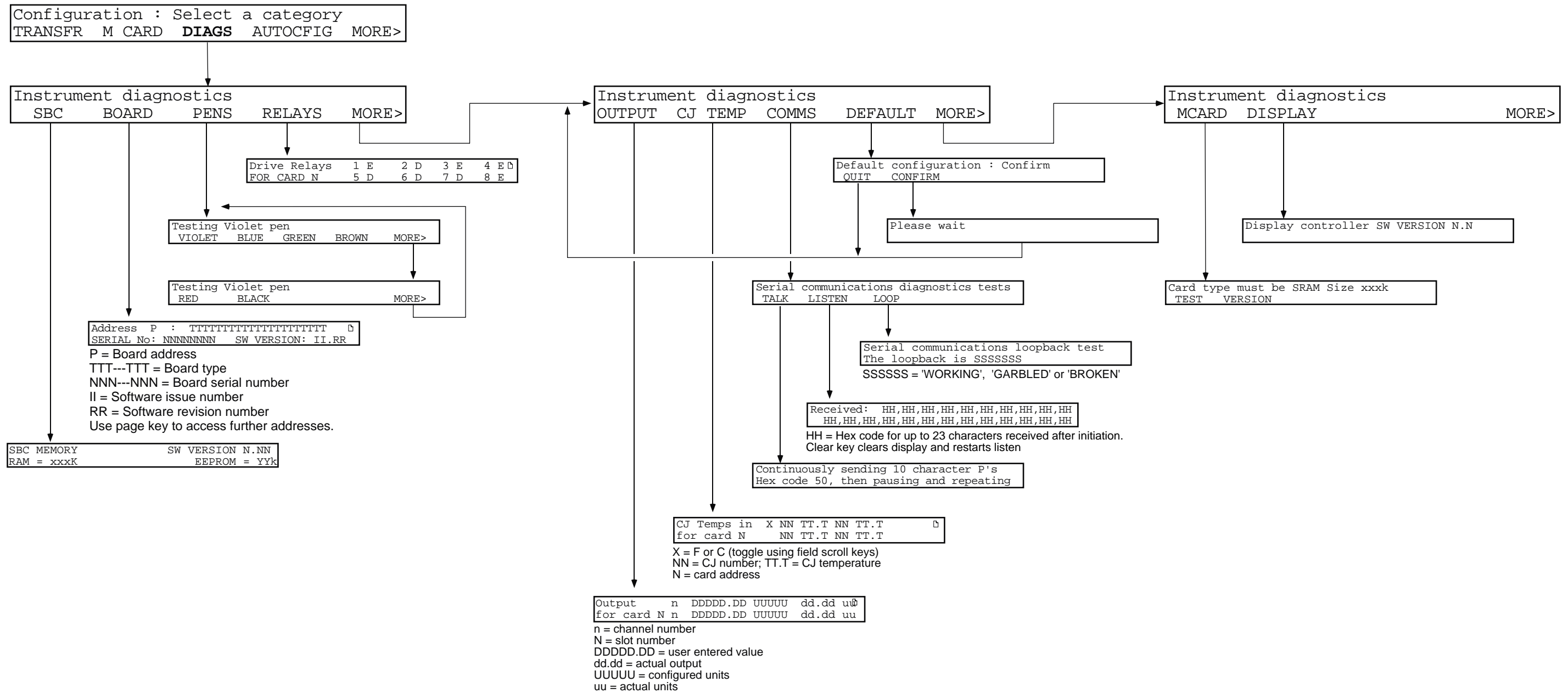

Figure 4.11
Diagnostics menu organisation

This page is deliberately left blank

4.11.6 CJ Temp

Shows the temperatures being measured by the cold junctions associated with the first relevant I/O board address. The field scroll keys can be used to toggle between Fahrenheit and Celsius. Further boards are accessed by using the field scroll keys.

4.11.7 Comms

Operation of this softkey calls a further 'softkey page' allowing the user to send or receive data, and to check that the communications line is working correctly. The communications tests are all run with the following parameters set: Baud rate = 9600; Data bits = 8; Stop bits = 1; Parity = None.

TALK

Operation of this softkey causes a string of ten characters P (hex 50) to be transmitted, followed by a pause, then a further 10 characters P.

LISTEN

Operation of this softkey causes the next 23 transmitted characters to be displayed. Operation of the Clear key clears the display before the next 23 characters are displayed.

LOOP BACK

BEFORE INITIATING THIS TEST, THE Tx AND Rx CONNECTIONS SHOULD BE SHORTED TOGETHER AT SOME POINT IN THE TRANSMISSION LINE.

Operation of this softkey calls the loopback test page, showing that up to the point at which Rx and Tx are shorted, the link is working correctly (WORKING), working incorrectly (GARBLED) or not working at all (BROKEN).

4.11.8 Default

Operation of this softkey, followed by operation of the CONFIRM softkey, causes the factory configuration to be written to the recorder's data base.

This operation overwrites any customer-entered configuration data.

4.11.9 M Card

TEST

Allows testing of the memory card and the memory card controller (if fitted).

Testing overwrites the memory card contents

VERSION

Operation of this softkey displays the version number of the memory card controller software.

4.11.10 Display

Operation of this softkey displays the version number of the display controller software.

4.12 AUTOCONFIGURATION

When triggered, the auto-configuration facility causes the recorder to determine whether any I/O boards, options etc. have been added or deleted, and changes the configuration as appropriate. The validity of data is checked, and if any area of the configuration is no longer valid, it re-configures it to a default state.

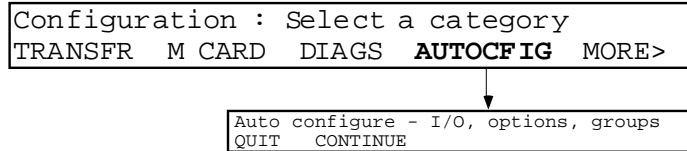

Figure 4.12 Auto-config configuration

QUIT	Returns to the previous 'Select a category' page.
CONTINUE	Causes the recorder to carry out automatic configuration.

4.13 OPERATOR ACCESS CONFIGURATION

This section shows how certain parts of the recorder's configuration, normally accessible via the Operator's menu, can be made inaccessible and *vice-versa*. Operation of the ACCESS softkey calls the first of the access category pages. Figure 4.13 shows the complete menu, allowing the items listed in table 4.13, below, to be toggled between Operator accessible (yes) and 'Not available' (no). The table below gives factory settings (defaults).

Chart	Speed A to Speed B (yes)	Counters	Preset counter (no)	
	Log interval A to Log interval B (yes)		Totalisers	Preset totaliser (no)
	Mode A to Mode B (no)		Timers	Control timers (no)
	Printer on/off line (yes)			Memory Card
Channel	Alarm setpoints (no)	Save / Restore configuration (no)		
Text	Edit operator messages (yes)	Display status / directory (no)		
	Group	Select specified group for display (yes)	Delete files (no)	
Log	Initiate logging of specified log (yes)	Select archive interval B (no)		
Maths	Reset derived channels (no)	Set memory card off line (no)		
	Alarm setpoints (no)			

Table 4.13 Operator access parameters

4.13 OPERATOR ACCESS (CONT.)

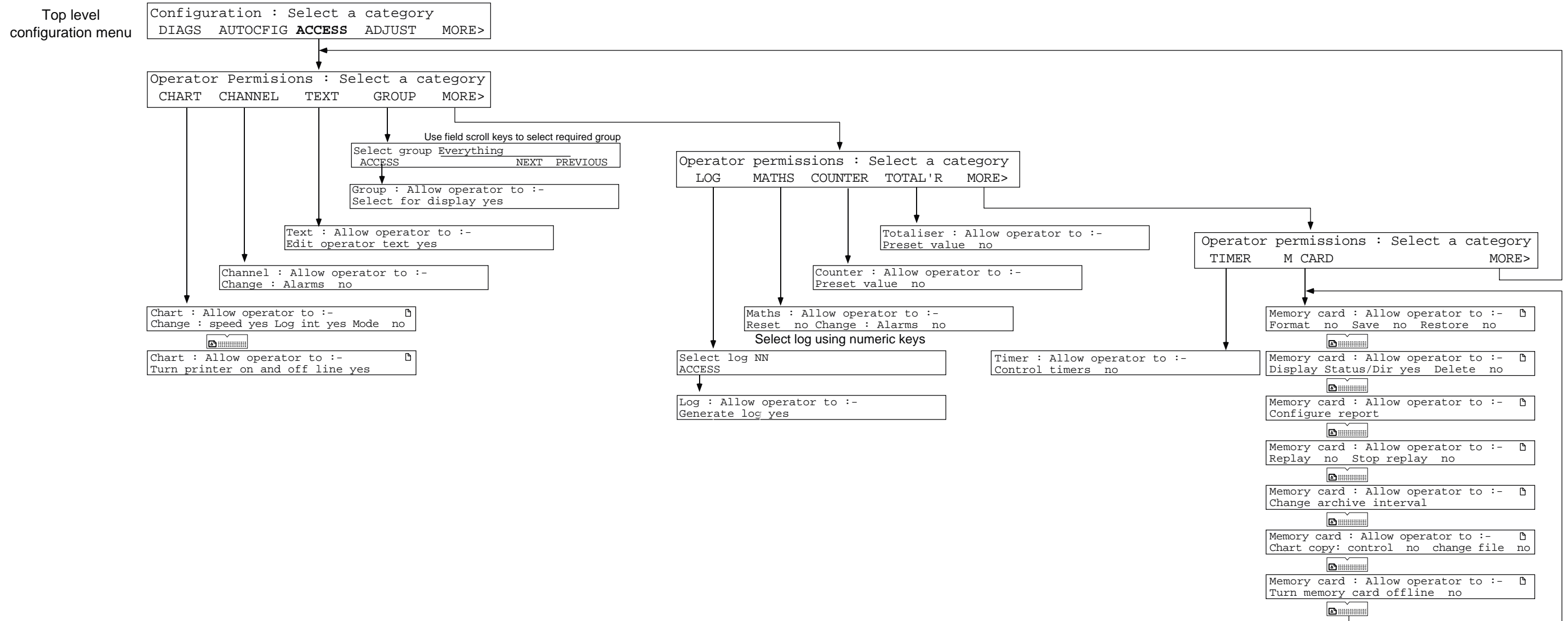

Figure 4.13
Operator access configuration

This page is deliberately left blank

4.14 ADJUST

Note: Any adjustments made in this section of configuration are lost during a configuration transfer (section 4.10 of this manual)

4.14.1 Input adjust

This section describes how the input/output channels can be adjusted to the required range for non-standard inputs, how the print head is aligned with the chart calibration marks, and how to calibrate input channels. The adjustments are in four subsections: Input, Output, Chart and Calibration.

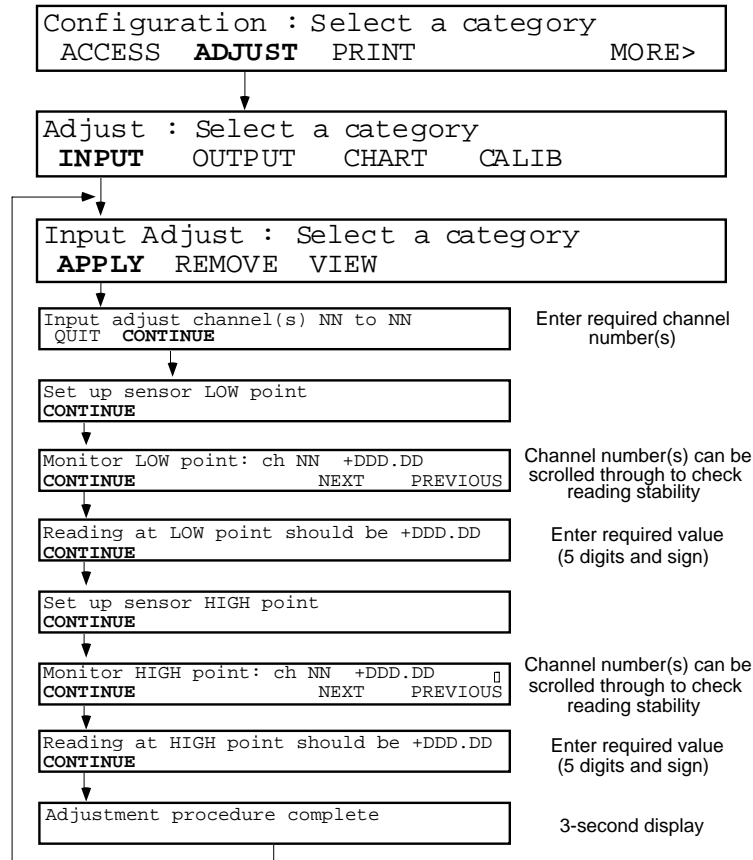

Figure 4.14.1 Channel Input Adjust menu

To adjust one or more channels, the prompts are followed as shown in figure 4.14.1 above. Numbers of channels to be adjusted and required values are entered using the numeric keypad. The monitor pages can be used for scrolling through the channels to ensure that the readings are all steady before adjustment is applied.

4.14.1 INPUT ADJUST (Cont.)

REMOVE

Note: It is possible to disable input adjustment, using the 'VIEW' page described below.

In order to remove any adjustment, the REMOVE softkey is operated to call the first 'remove' page:

```
Remove input adjust for ch(s) NN to NN
QUIT CONFIRM
```

Operation of the CONFIRM softkey causes a return to the 'INPUT, OUTPUT, CHART, CALIB' page, via a 'fleeting' display page: 'Adjustment removal complete', which displays for three seconds.

VIEW

Operation of the VIEW softkey will call one of the two pages depicted below:

```
NN DDDDDDDDDDDDDDDDDDDDD unadjusted
```

```
NN DDDDDDDDDDDDDDDDDDDDD adjusted
Use adjustment YYY
```

In both cases, NN is the channel number, and DDD—DDD is the channel descriptor. The page scroll key can be used to scroll through the channel numbers.

The 'Use adjustment' field can be used to disable the adjustment, when set to 'no'. Use adjustment is set to 'Yes' as a default.

4.14.2 Output adjust

This allows the range of the analogue output to be adjusted to account for tolerance errors in external equipment. The technique used is:

- 1 To specify a low point and, after a stabilisation time, to enter the value which is read by the external equipment.
- 2 To repeat the above for a high point.

The output board then calculates new offsets and gains for the channel.

Notes:

1. The CLEAR key is used to set the DDDDD.DD value to zero.
2. Adjust REMOVE and VIEW operate in a similar way to that described for input channels above.
3. Adjust is not available for channels with 'Constant' as their input source.

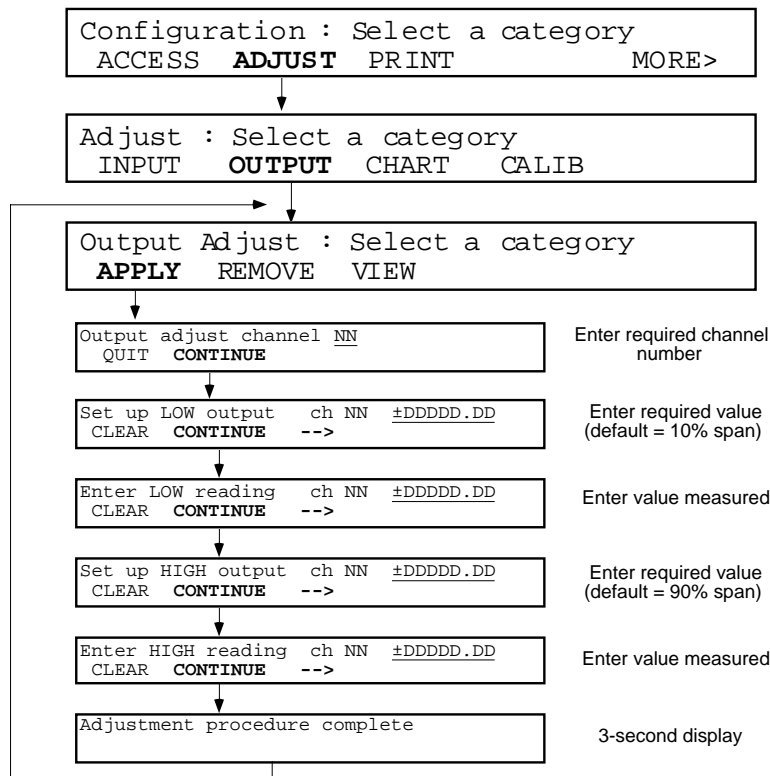

Figure 4.14.2 Output channel adjust menu

4.14.3 Chart adjust

Operation of the CHART softkey causes the recorder to go into pen calibration mode. The printhead continuously scans from zero to full scale, leaving lines of dots at or close-to the zero, centre and full scale calibrations of the chart. The display changes as follows:

```

Chart paper calibration
<<ZERO  ZERO>>  ALIGN  <<SPAN  SPAN>>
  
```

The ALIGN softkey is used as many times as is necessary to set the central line as straight as possible. The <<zero and zero>> softkeys are then used to align the printhead zero with the chart zero, and the <> softkeys are used to align the printhead full scale with the chart full scale.

Operation of the Enter hard key causes the new zero and span to be read into the recorder. On the second operation of Enter, the display returns to the 'INPUT, OUTPUT, CHART, CALIB' page.

4.14.4 CALIB softkey

This feature allows the user to calibrate 8-channel universal input board channels to his or her own requirements. The facility is not available for the 16-channel dc input board. It is recommended that for maximum accuracy, the Input calibration be carried out before the Cold Junction calibration.

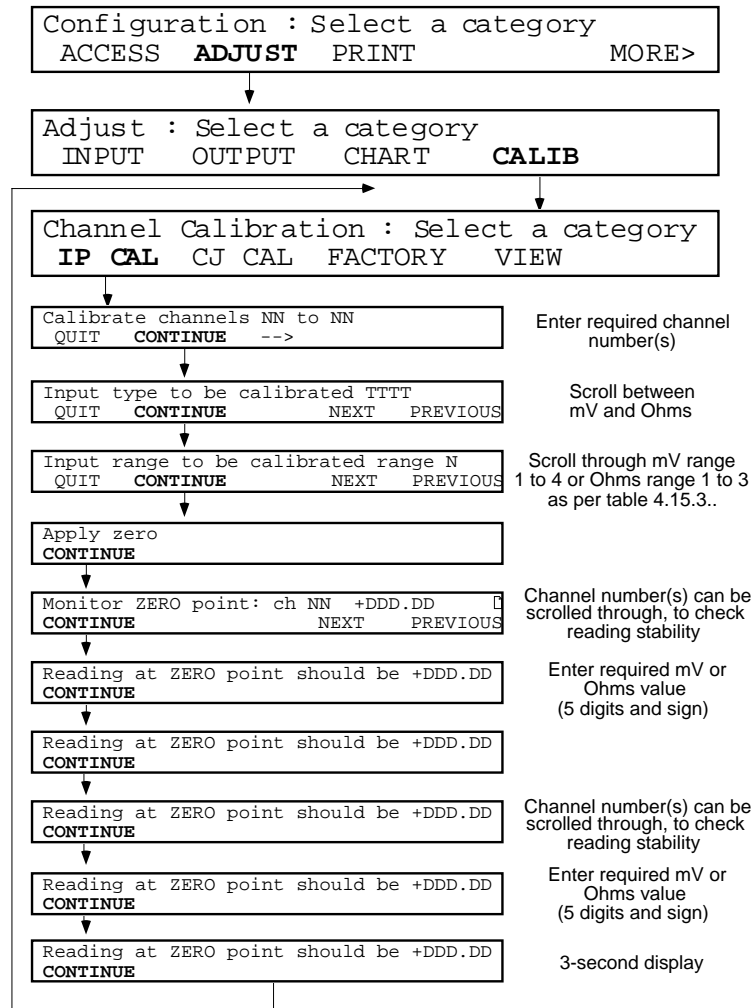

Figure 4.14.4 Input channel calibration menu

The input ranges (range N) above, are given in table 4.14.4 below. The user must choose the lowest possible of the available ranges which will suit the application.

Range number	mV Ranges	Range number	Ohms Ranges
1	0 to 40 mV	1	0 to 180 Ω
2	0 to 200 mV	2	0 to 1800 Ω
3	0 to 1000 mV	3	0 to 10000 Ω
4	0 to 10000 mV		

Table 4.14.4 Input ranges

4.14.3 CALIB SOFTKEY (Cont.)

CJC Calibration

Before this procedure can be carried out it is necessary to connect a thermocouple, (or thermocouple simulator) of a known type, held at a known reference temperature, to each of the input channels to be calibrated. The channels must then be configured for that type of thermocouple, and have 'internal' set as their cold junction compensation type.

Operation of the CJ CAL softkey calls the first Cold Junction calibration page to the display:

```
Calibrate cj(s) for channel(s) NN to NN
QUIT CONTINUE ->
```

The relevant channel number(s) are entered using the cursor and numeric keys. 'CONTINUE' calls the next page:

```
Apply reference temperature
QUIT CONTINUE
```

Continue calls the next page:

```
Monitoring reference : ch NN +DD.DDD
CONTINUE
```

The page scroll keys can be used to scroll through the selected channels to ensure that they are all stable, before the adjustment is applied. Continue calls the next page:

```
Reference temperature is TT.T °C
CONTINUE
```

The known reference temperature (TT.T) is entered using the numeric keys. CONTINUE initiates the calibration procedure.

```
CJ calibration procedure complete
```

Operation of the FACTORY softkey calls the 'Use factory cal' page to the display. The relevant channel numbers are entered using the cursor and numeric keys.

```
Use factory cal for channel(s) NN to NN
QUIT CONFIRM ->
```

Operation of CONFIRM returns the relevant channel(s) (including CJs) to factory calibration. A 'fleeting' display (Return to factory cal procedure complete) appears for three seconds.

4.14.3 CALIB SOFTKEY (Cont.)

VIEW

Operation of the VIEW softkey allows each channel to be scrolled through, to determine whether factory or field calibrations are in use for input and cold junction compensation.

```

NN DDDDDDDDDDDDDDDDDDDDDDD cal being use
Input : FFFFFFFF Cold junction : FFFFFFFF

```

where NN is the channel number, DDD — DDD is the channel descriptor and FFFFFFFF is either 'Factory' or 'Field' as appropriate.

The page scroll keys can be used to view other channels.

4.15 PRINT CONFIGURATION

This allows the instrument configuration to be output to the chart.

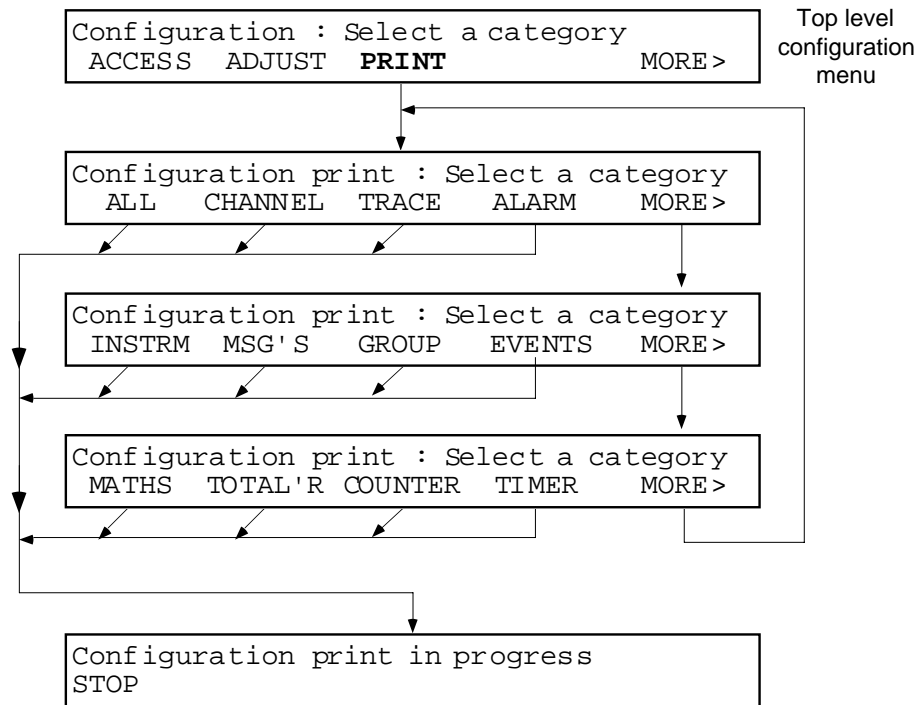

Figure 4.15 Configuration print

Note: Operation of the 'ALL' softkey causes a full configuration print. Operation of any other softkey causes only that section to be printed.

SECTION 5 : OPTIONS.

LIST OF CONTENTS

Section	Page
5.1 INSTALLING NEW OPTIONS	5 - 3
5.2 TOTALISER / COUNTER / TIMER (TCT) OPTION	5 - 4
5.2.1 Totalisers	5 - 4
TOTALISER CONFIGURATION	5 - 4
5.2.2 Counters	5 - 6
COUNTER CONFIGURATION	5 - 6
5.2.3 Timers	5 - 8
CONFIGURATION	5 - 8
5.3 MATHS PACK	5 - 10
5.3.1 Introduction	5 - 10
5.3.2 Configuration	5 - 10
5.3.3 Maths functions	5 - 12
MATHS PACK LEVEL ONE	5 - 12
MATHS PACK LEVEL TWO	5 - 12
5.3.4 Equations	5 - 13
CHANNEL AVERAGE	5 - 13
GROUP AVERAGE	5 - 13
ROLLING AVERAGE	5 - 13
RATE OF CHANGE	5 - 13
RELATIVE HUMIDITY	5 - 14
FVALUE	5 - 15
MASS FLOW LINEAR	5 - 16
MASS FLOW (SQUARE ROOT)	5 - 18
ZIRCONIA PROBES	5 - 19
SWITCH	5 - 20
HIGH SELECT	5 - 20
LOW SELECT	5 - 20
STOPWATCH	5 - 20
TIME STAMP	5 - 20

This page is deliberately left blank

SECTION 5 OPTIONS

This section contains details of options other than Communications, Memory Card and Networking, which are dealt with in separate manuals.

Note: When installing new options (as described below), the battery is disconnected from the control board, and any volatile information is lost. This information includes timer/counter/totaliser values, maths pack functions which have 'histories' such as averages, operator selections such as chart speed, chart on/off, display mode etc. and the real-time clock.

5.1 INSTALLING NEW OPTIONS

New options are fitted by inserting an 'Option Key' into a connector located on the control board at the rear of the writing system as follows:

Isolate the recorder from the supply.

Open the recorder door and swing the cassette down by operating both latches.

Undo the two captive screws ('A' in figure 5.1a), and pull the writing system forwards until it meets the stops (figure 5.1b).

Lift the writing system out of the case, disconnecting the power, I/O and any other looms as shown in figure 5.1c

Whilst observing the relevant static precautions detailed near the beginning of this manual, the option locations on the control board (B in figure 5.1c) can now be accessed by removing the plastic rivets at the top of the board, then carefully lifting and tilting the board back and away.

Release as many connectors as are necessary to allow the insertion of the new option key. Note that the flexible cable is a push fit into its (zero insertion force) connector.

Fit the option key(s). Re-fit the control board re-making all the connectors previously disconnected. Return the writing system to the case, ensuring that all connectors are re-made, and secure it with the two captive screws.

Apply power to the recorder and use the 'Autoconfigure' facility (section 4.12) to include the new option(s) in the data base. Set the date and time as described in section 4.2.1

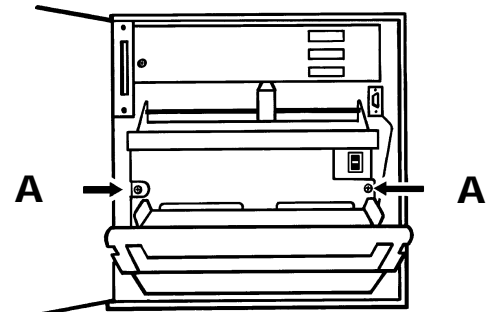

Figure 5.1a
Writing system securing screws

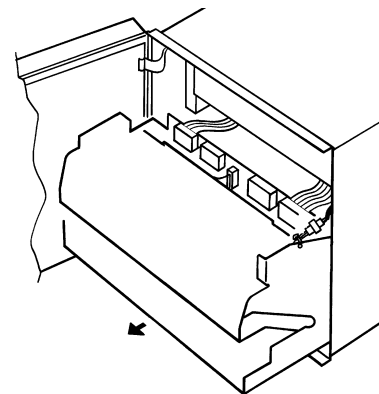

Figure 5.1b Pull writing system forwards

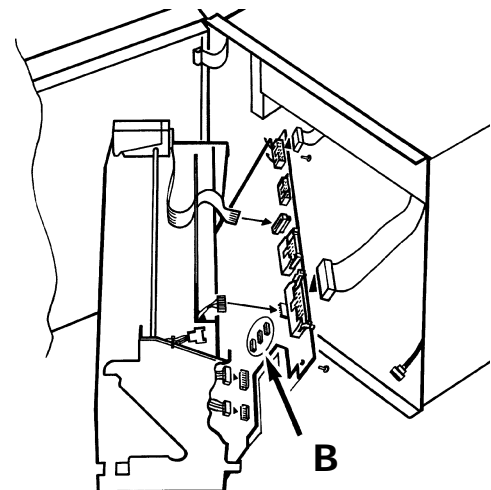

Figure 5.1c Option key locations

5.2 TOTALISER / COUNTER / TIMER (TCT) OPTION

5.2.1 Totalisers

The TCT option contains 12, eight-digit totaliser functions, each of which is used to integrate a given input or derived channel's input, providing that it is above a low cut-off point, below a high cut-off point and within the channel's range.

A 'setpoint' value can be entered, and when the totaliser value exceeds this threshold, up to two actions (job list) are carried out. The jobs remain active until the totaliser is reset or disabled.

The function equation is:
$$tot_t = tot_{t-1} + \frac{ma_t}{PSF \times USF}$$

Where

- tot_t = totaliser value at time t.
- tot_{t-1} = totaliser value last time
- ma_t = input value of source channel (Ca) at time t
- PSF = Period scaling factor
- USF = Units scaling factor (negative for decrement; positive or un-signed for increment).

TOTALISER CONFIGURATION

FUNCTION SOFTKEY

PAGE 1	
Enabled/Disabled	Allows the totaliser to be turned on or off.
Source	Number of the input or derived channel to be used as the totaliser source.
Period scaler (PSF)	Changes time units of input to seconds. E.g. If input is litres / hour then PSF = 3600.
Units scaler (USF)	Changes the counting scale. E.g. If Input = litres/sec and the output is to be litres $\times 10^3$ (i.e. thousands of litres), then USF is set to 1000. Direction of count is defined by the sign of the USF, a negative USF causing the totaliser to decrement.
PAGE 2	
Group reset	Allows the totaliser to be susceptible to group reset (enable) or not (disable).
Preset	Allows entry of an eight-digit preset value, from which the totaliser will count after being preset
Cut off low	Value of the source channel (in engineering units) below which it is not to be totalised (can be negative).
Cut-off high	Value of the source channel (in engineering units) above which it is not to be totalised (must be positive).
PAGE 3	
Value format	Allows the number of decimal places to be selected for the displayed value.

ALARM SOFTKEY

SET PT SOFTKEY	
Set Point	Eight digit value entered using the numeric keys to act as the trip point for the job list.
Limit	Scroll through 'High' or 'Low'. Defines whether job list is initiated when the totaliser exceeds the setpoint (High) or when it falls below it (Low).
JOBS SOFTKEY	
	Allows jobs 1 or 2 to be selected from the list given in section 4.1.3. Can be used to reset totaliser.

IDENT SOFTKEY

	Allows a 17-character descriptor, a units string and a seven-character tag to be entered to describe the totaliser function.
--	--

TOTALISER CONFIGURATION (Cont.)

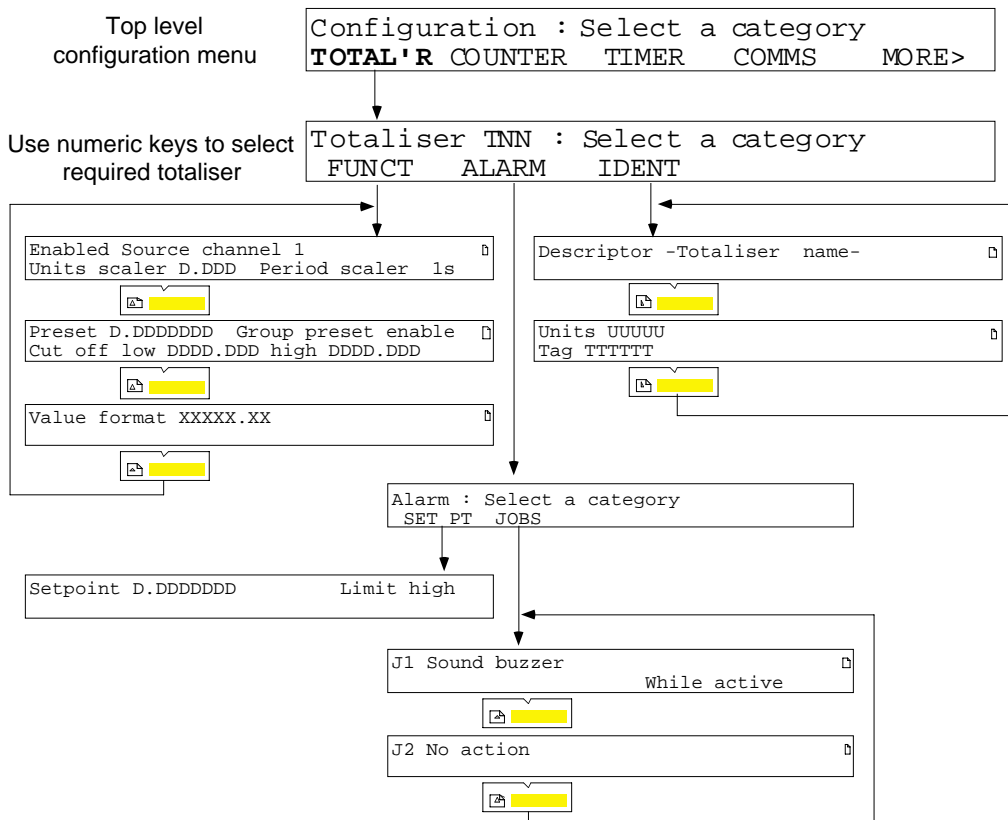

Figure 5.2.1 Totaliser configuration

Note: Totaliser values are held in battery-backed memory and are thus retained even when power is removed. It is recommended that the recorder is left switched ON whilst the battery pack is being replaced to ensure that totaliser values are not lost.

5.2.2 Counters

The TCT option supplies 12, eight-character counters which are controlled from other recorder functions through job lists. As shown in section 4.1.3, counter jobs are:

- a. Increment specified counter.
- b. Decrement specified counter.
- c. Preset specified counter or group of counters.
- d. Disable specified counter or group of counters.

Each counter is configured with a threshold to allow it to trigger up to two jobs itself. A 'limit' input allows these jobs to be initiated either when the count value exceeds the threshold (Limit high) or when it falls below the threshold (Limit low).

Counters values are non volatile, i.e. the values are maintained with power removed from the recorder. In order to maintain this function, power must be maintained to the recorder whilst the batteries are being replaced (section 6.2).

COUNTER CONFIGURATION

The required counter (NN in figure 5.2.2) is selected using the numeric keys.

PRESET	Preset	Eight-digit value of preset, entered using the numeric keys. The value is loaded into the counter by 'preset specified counter' job (section 4.1.3), or by operator action.
	Group Preset enable	Scroll through 'enable' or 'disable' to define the counter as being susceptible to group Preset (enable) or not (disable).
ALARM	SET PT	Set Point An eight-digit value entered using the numeric entry keys. Acts as the trip point for the job list.
		Limit Scroll through 'High' or 'Low'. Defines whether job list is initiated when the counter exceeds the setpoint (High) or when it falls below it (Low).
	JOBS	Allows up to two jobs to be set up to be initiated when the counter value passes the threshold value. See section 4.1.3 for job details.
IDENT	Descriptor	Allows the entry of a title of up to 17 characters, to describe the counter's use and to distinguish it from other variables.
	Units	Allows a units string to be entered for the counter value.
	Tag	Allows a 7-character 'tag' to be entered for the counter

COUNTER CONFIGURATION (Cont.)

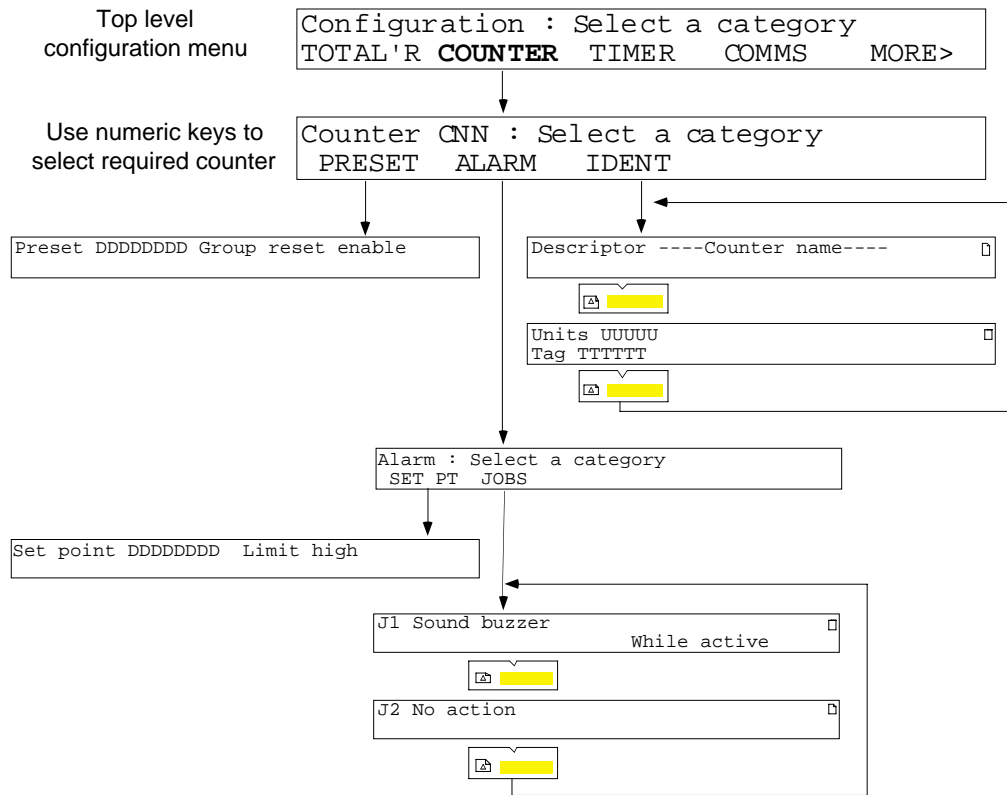

Figure 5.2.2 Counter configuration

5.2.3 Timers

The TCT option supplies 12 timers, each of which can be configured to start at a specific time and date (according to the real-time clock in the recorder). The timer will then run for a configurable time period (duration), and will repeat at a configurable rate. Alternatively, the timer can be initiated by a job (see 'Timer' jobs in section 4.1.3), and it will then repeat at the configured repetition rate. Once initiated, the timer will re-start every repeat period until it is disabled.

Each timer can have up to two jobs allocated to it from the list in section 4.1.3. The jobs are active for the timer Duration period.

Timer values are non volatile, i.e. the values are maintained with power removed from the recorder.

In order to maintain this function, power must be maintained to the recorder whilst the batteries are being replaced (section 6).

CONFIGURATION

The required timer (NN in figure 5.2.3) is selected using the numeric keys.

FUNCT Page 1		
Enabled		Scroll through 'enabled' or 'disabled' to enable or disable the timer respectively.
Global reset enable		Scroll through 'enable' or 'disable' to define the timer as being susceptible to global reset (enable) or not (disable).
Start at		Field scroll keys are used to enter time and date at which the timer is to start. (XX = 'Don't care' see note and example below). If all fields are XX, the timer can be started only by job or operator action.
FUNCT Page 2		
Repeat every		Days, hours, minutes and seconds values are entered using the numeric keys, to define repeat period. If all zeros entered, timer does not repeat.
Duration		Numeric entry of timer duration.
JOBS		Allows up to two jobs to be set up to be active for the timer duration. See section 4.1.3 for job details.
IDENT	Descriptor	Allows the entry of a title of up to 20 characters, to describe the timer's use and to distinguish it from other variables.

Note: If no entry (i.e. XX) is made in the first field, then the timer operates every next smallest defined time period. For example, if no month is entered, but a day number of 01 is entered, then the timer will operate on the 1st day of each month. If no month or day value is defined, but an hours value of 12 is entered, then the timer will operate every day at noon.

EXAMPLE

To start a timer at mid day on the 1st of each month:

```
Enabled          Global reset enable
Start at XX/01 month/date 12:00 hr:mins
```

TIMER CONFIGURATION (Cont.)

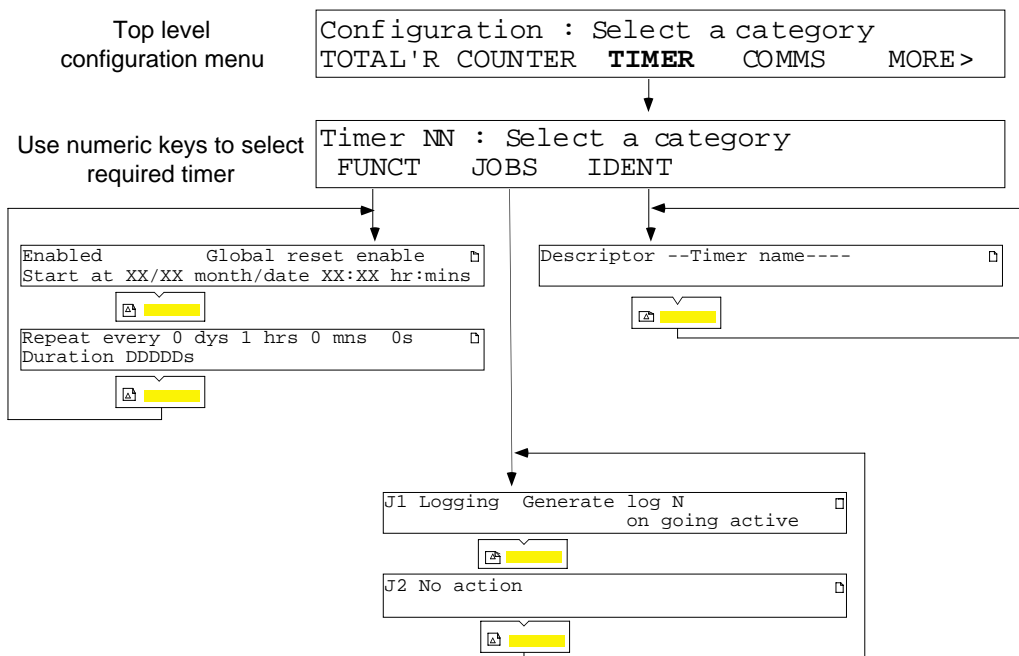

Figure 5.2.3 Timer configuration

5.3 MATHS PACK

5.3.1 Introduction

The maths pack option is available in two versions called level 1 and level 2, both of which support 24 derived channels (D1 to D24) and differ only in the number of functions available (section 5.3.3).

When the source channel is being selected, operation of the key allows the operator to toggle between input channels and derived channels (prefixed with a 'D' at the display and on the chart).

The operation and configuration of derived channels are similar to that described for measuring channels, and share the following parameters.

Channel units	Five-character, user-definable string
Zone	Spans, scales and print zones as for measuring channels
Trace	On, off or conditionally on as for measuring channels
Colour	Colours A and B selectable as for measuring channels
Descriptor	17-character descriptor as for measuring channels
Tag	Seven-character tag as for measuring channels
Alarms	Types, setpoints, hysteresis etc. as for measuring channels, though derived channel alarms and measuring channel alarms are not mixed on the Operator's alarm overview page; Derived channel alarms appear as a separate list, after measuring channel alarms.
Jobs	Type and actions etc. as for measuring channels

Maths pack unique parameters are as follows:-

Value format Each derived variable and associated parameters can be displayed in the following ways:

Five digits with configurable decimal point position

Seven digits with configurable decimal point position

Eight digit integer (no decimal places).

Scientific (X.XXX+ee) e.g. 12324 would be expressed as 1.232+04; 0.000012324 would be expressed as 1.232-05.

In addition, the following time/date formats are available:

Time as HH:MM:SS (Time part of Time Stamp function).

Date as DD/MM/YY or MM/DD/YY (Date part of Time Stamp function). Date format is specified as a part of 'Instrument' configuration.

Elapsed time as HH:MM:SS. If the period is 100 hours or more, the format changes to HHHHH:MM.

Group reset enable Allows the derived channel value to be reset as a part of a group reset.

5.3.2 Configuration

Figure 5.3.2 shows the configuration pages for the FUNCT softkey. After the FUNCT softkey has been operated, the function type is selected using the field scroll keys. Operation of the page scroll key results in the relevant configuration page for that function to appear. After all the necessary sources have been defined, the page scroll key is again operated to call the 'Group reset and value format' page to the display.

Alarm, Zone, Trace and Ident configuration are the same as for measuring channels.

5.3.2 MATHS PACK CONFIGURATION (Cont.)

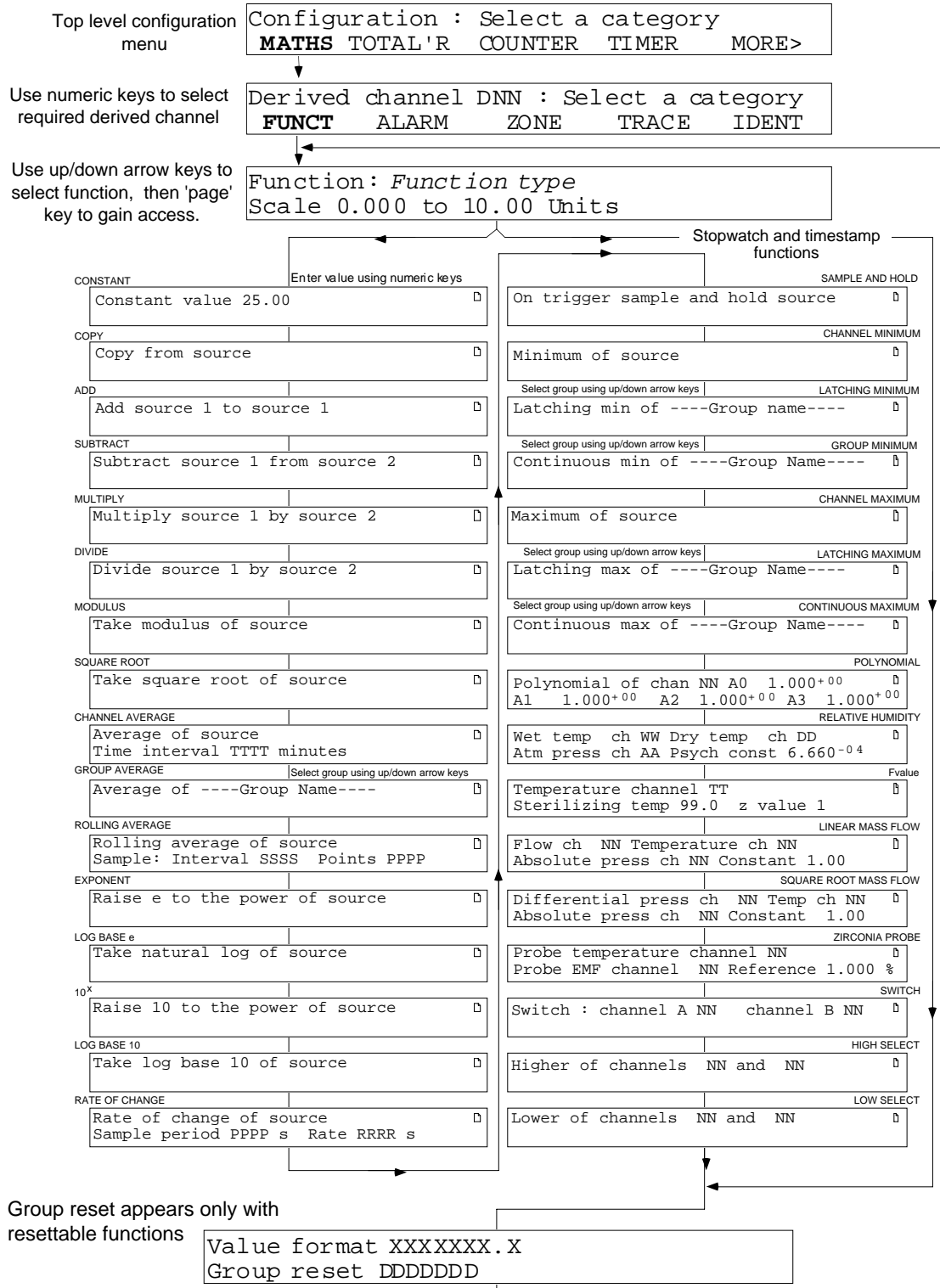

Figure 5.3.2 Derived channel configuration

5.3.3 Maths functions

The following maths functions are available. Unless otherwise stated, the word 'channel' is used as a general term to include both input (measuring) and derived channels.

MATHS PACK LEVEL ONE

Constant	Allows entry of a constant
Copy	Allows a totaliser or counter value to be imported.
Add	Adds two channels together.
Subtract	Subtracts one channel from another
Multiply	Multiplies two channels together
Divide	Divides one channel by another
Modulus	Takes the value of the input without the sign.

MATHS PACK LEVEL TWO

Square root	Takes the square root of a channel.
Channel average	Takes the average of the value of a channel over a configurable time period, then resets and repeats.
Group average	Takes the average of a named group of channels.
Rolling average	Takes the continuous average value of a channel at a specified sample rate, over a specified time period. For example, it may take the average of readings made every 5 minutes over the past half hour, where 'the past half hour' is continuously rolling (I.E. the first reading is discarded when the seventh one is taken and so on)
Exponent	Provides the value of e raised to the power of a specified channel
Log_e	Takes the 'natural' log of a specified channel's value.
10^x	Output is 10 raised to the power of a specified channel.
Log_{10}	Take log_{10} of the channel value
Rate of change	Determines the change in value of the source channel over a specifiable time period.
Sample and hold	Allows the value of a channel to be held as a result of a trigger input.
Channel minimum	Holds the minimum value reached by a specified channel since the function was started.
Latching minimum	Holds the minimum value reached by any channel in a specified group, since the function was initiated.
Continuous min.	The current minimum value out of all the channels in a specified group.
Channel maximum	Holds the maximum value reached by a specified channel since the function was started.
Latching maximum	Holds the maximum value reached by any channel in a specified group, since the function was initiated.
Continuous max.	The current maximum value out of all the channels in a specified group.
Polynomial	Third order polynomial curve fit $A0 + A1(X) + A2(X^2) + A3(X^3)$, where X is the value of the source channel and A0 to A3 are constants.
Relative humidity	Calculates relative humidity from wet and dry temperature inputs, atmospheric pressure input and psychrometric constant input.
F value	Calculates Fo or Fh from temperature and Z-value inputs.
Linear mass flow	Calculates mass flow from linear type transducer output.
Square root mass flow	Calculates mass flow from square root type transducer output.
Zirconia probe	Solves the Nernst oxygen equation.
Switch	Copies one of two channels selected as input sources.
High select	Output is the higher of two source channels' values.
Low select	Output is the lower of two source channels' values.
Stopwatch	Increments four times per second whilst enabled.
Time Stamp	Holds current time and date value when triggered by a job.

5.3.4 Equations

CHANNEL AVERAGE

To provide the arithmetic mean of a channel over a specified time period.

$$A'_t = \frac{\sum_{i=1}^{T \times 60} ma_t}{T \times 60}$$

Where, A_t = Channel average at time t
 ma_t = Value of channel to be averaged, at interval sample time t
 T = Time interval in minutes

GROUP AVERAGE

To provide the average value of a all the channels in a group.

$$A_t = \frac{(ma_t + \dots + mn_t + \dots + mx_t)}{R}$$

Where, A_t = Mean value of the specified group of channels at time t
 ma_t = Value of first channel in the group at time t
 mn_t = Value of nth channel in the group at time t
 mx_t = Value of final channel in the group at time t
 R = Number of channels in the group

ROLLING AVERAGE

To calculate continuously, the arithmetic mean of a specified number of consecutive readings of a source channel. The user configures the number or readings (points) to be averaged, and the time between samples.

$$A_t = \frac{\sum_{s=1}^{s=PT} ma_{(t-s)}}{P}$$

Where A_t = Rolling average of specified channel at time t.
 ma_{t-s} = Value of specified channel at time t - s.
 P = Number of readings to be averaged.
 T = Sample interval in seconds.

At reset, the time period is restarted and the P set to zero.

RATE OF CHANGE

To calculate the rate of change (d/dt) of the value of a specified channel.

$$A_t = \frac{(ma_t - ma_{(t-Ta)}) \times R}{P}$$

Where, A_t = Rate of change value
 ma_t = Current value of source channel
 ma_{t-Ta} = Value of source channel last time
 R = Rate multiplier in seconds to give rate per minute, per hour etc. from sample rates of minutes, seconds etc.
 P = Sample period in seconds (time between successive calculations).

5.3.4 EQUATIONS (Cont.)

RELATIVE HUMIDITY

To determine the percentage relative humidity using wet and dry temperature, and atmospheric pressure inputs.

Note: The psychrometric constant used in the calculation (to be entered by the user) is generally 6.66×10^{-4} .

$$\% RH = \frac{VP_{Air}}{VP_{Sat}}$$

Where VP_{air} = the water vapour pressure in the atmosphere being measured
 VP_{sat} = the saturated water vapour pressure at the measured dry bulb temperature.

VP_{AIR} CALCULATION

VP_{air} is calculated as follows:

$$VP_{Air} = VP_{Wetsat} - \{6.66 \times 10^{-4} \times mc_t \times (ma_t - mb_t)\}$$

where, ma_t = value of the channel measuring dry bulb temperature (°C)
 mb_t = value of the channel measuring wet bulb temperature (°C)
 mc_t = value of the channel measuring the atmospheric pressure (bar)

$$VP_{Wetsat} = A0 + (A1 \times mb_t) + (A2 \times mb_t^2) + (A3 \times mb_t^3) + (A4 \times mb_t^4) + (A5 \times mb_t^5)$$

VP_{wetsat} = the saturated water vapour pressure at the measured wet bulb temperature, calculated as follows:

where, $A0 = 6.17204663 \times 10^{-3}$
 $A1 = 4.28096024 \times 10^{-4}$
 $A2 = 1.53342964 \times 10^{-5}$
 $A3 = 2.40833685 \times 10^{-7}$
 $A4 = 3.04249240 \times 10^{-9}$
 $A5 = 2.65867713 \times 10^{-11}$

VP_{SAT} CALCULATION

$$VP_{Sat} = A0 + (A1 \times ma_t) + (A2 \times ma_t^2) + (A3 \times ma_t^3) + (A4 \times ma_t^4) + (A5 \times ma_t^5)$$

VP_{sat} is calculated as follows:

where ma_t , and A0 to A5 are as described for VP_{Wetsat} above.

5.3.4 EQUATIONS (Cont.)

FVALUE

To calculate the equivalent time at Sterilizing Temperature (for temperatures below, at and above Sterilizing Temperature) both in dry (FH) and steam (Fo) sterilizing environments, using the following equation:

$$Fval_t = Fval_{t-1} + T \times 10^{\frac{ma_t - \text{target temp}}{Z}}$$

Where $Fval_t$ = F value at time t (minutes)

$Fval_{t-1}$ = F value last iteration

T = Internal recorder iteration rate (minutes)

ma_t = Value of temperature measuring channel

Target temp = 121.1°C for Fo; 170°C for FH

Z = Temperature interval representing a factor-of-10 reduction in killing efficiency

= 10°C for Fo; = 20°C for FH

Application Notes

To ensure that sterilizer loads which contain materials with differing thermal inertias are thoroughly sterilized, a typical sterilizer has up to 12 different measuring points within the load. To ensure accuracy, the temperature sensors should be calibrated, and the channel adjustment facility used to compensate for any inaccuracies found.

If each of the inputs is used to compute an F value, each of these values can then be used as an input to a Group Continuous Minimum function, with a high absolute alarm set at the correct F value. The alarm can be used to sound a warning, or an associated relay can be linked into the autoclave control system to signify the end of a sterilization cycle.

5.3.4 EQUATIONS (Cont.)

MASS FLOW LINEAR

Note: The overall accuracy of a flow measurement installation depends on a number of factors outside the control of the recorder manufacturer. For this reason, the manufacturer takes no responsibility for the accuracy of results obtained using the mass flow equations implemented in the maths pack.
It is not recommended that the recorder be used for custody transfer.

$$Qm_t = \frac{K}{Rg \times Z} \times \frac{Flow_t \times AbsP_t}{Temp}$$

where,

- Qm_t = mass flow in kg/sec.
- $Flow_t$ = measured value from the flow meter at time t
- $AbsP_t$ = absolute pressure of the fluid at time t in kPa(A).
- $Temp$ = absolute temperature (Kelvin) of the fluid.
- K = scaling factor (see below).
- Rg = specific gas constant in J/(kg-K) (see below)
- Z = compressibility factor (see below).

For the recorder user, the equation above becomes:

$$Mass\ flow = \frac{md \times ma_t \times mb_t}{mc_t}$$

where

- ma_t = the value, at time t, of the channel measuring the flow meter output
- mb_t = the value, at time t, of the channel measuring the absolute pressure of the fluid.
- mc_t = the value, at time t, of the channel measuring the fluid temperature.
- md = the constant value derived from the following:

$$Const = \frac{K}{Rg \times Z}$$

SCALING FACTOR (K)

This is calculated from the following equation:

$$K = \frac{S}{ma_{max}}$$

where,

- S = the full scale output from the flow meter
- ma_{max} = the full scale input of the channel reading the output from the flow meter.

5.3.4 MASS FLOW (LINEAR) (Cont.)

SPECIFIC GAS CONSTANT (R_g)

The specific gas constant values are available from published tables. For convenience, the R_g values for a number of common gases are given in table 5.3.4 below.

Gas	R _g (J/kg·K)
Air	287.1
Ammonia (NH ₃)	488.2
Carbon dioxide (CO ₂)	188.9
Carbon monoxide (CO)	296.8
Ethylene	296.4
Hydrogen (H ₂)	4116.0
Methane (CH ₄)	518.4
Nitrogen (N ₂)	296.8
Oxygen (O ₂)	259.8
Propane (CH ₃ CH ₂ CH ₃)	188.5
Steam (H ₂ O)	461.4

Table 5.3.4 Common gas constants

COMPRESSIBILITY FACTOR (Z FACTOR)

The compressibility factor is a density related measure of how far a particular gas deviates from a 'perfect' gas under any set of temperature and pressure conditions, and is given by the equation:

$$Z = \frac{P}{T} \times \frac{1}{\rho}$$

where,

Z = Compressibility factor

P = Absolute pressure of the gas

T = Absolute temperature of the gas.

ρ = Gas density at pressure P and temperature T (from published tables)

Alternatively the Z-factor can be obtained experimentally.

5.3.4 EQUATIONS (Cont.)

MASS FLOW (SQUARE ROOT)

Note: The overall accuracy of a flow measurement installation depends on a number of factors outside the control of the recorder manufacturer. For this reason, the manufacturer takes no responsibility for the accuracy of results obtained using the mass flow equations implemented in the maths pack.

It is not recommended that the recorder be used for custody transfer.

$$Qm_t = \sqrt{\frac{K^2}{Rg \times Z}} \times \sqrt{\frac{\text{Delta}P_t \times \text{Abs}P_t}{\text{Temp}_t}}$$

where,

- Qm_t = mass flow in kg/sec.
- $\text{Delta}P_t$ = measured value of differential pressure across the orifice plate at time t, in kPa.
- $\text{Abs}P_t$ = absolute pressure at the upstream tapping at time t, in kPa(A).
- Temp_t = absolute temperature at the upstream tapping at time t, in Kelvin.
- K = Scaling factor (see below).
- Rg = Specific gas constant in J/(kg-K)
- Z = Compressibility factor

For the recorder user, the equation above becomes:

$$\text{Mass flow} = \sqrt{\frac{md \times ma_t \times mb_t}{mc_t}}$$

where

- ma_t = the value, at time t, of the channel measuring the flow meter output
- mb_t = the value, at time t, of the channel measuring the absolute pressure of the fluid.
- mc_t = the value, at time t, of the channel measuring the fluid temperature.
- md = the constant value derived from the following:

$$\text{Const} = \frac{K^2}{Rg \times Z}$$

Where,

- K = scaling factor (see below)
- Rg = Specific gas constant in J/kg-K (see mass flow (linear) above).
- Z = Compressibility factor (see mass flow (linear) above).

SCALING FACTOR (K)

This is calculated from the following equation:

$$K = \frac{S}{\sqrt{ma_{\max}}}$$

where,

- S = the full scale output from the flow meter
- ma_{\max} = the full scale input of the channel reading the output from the flow meter.

5.3.4 EQUATIONS (Cont.)

ZIRCONIA PROBES

A Zirconia (oxygen) probe consists of two platinum electrodes bonded to a pellet or cylinder of Zirconia. At elevated temperatures, such a probe develops an electromotive force (emf) across it which is proportional to the probe temperature and to the log of partial pressure (oxygen) difference between its two ends.

OXYGEN CONCENTRATION MEASUREMENT

In order to measure oxygen concentrations, one end of the probe is inserted into the atmosphere to be measured, whilst the other end is subject to a reference atmosphere. For most applications, air provides a suitable reference (reference input = 20.95% for air).

The temperature of the probe is normally measured using a type K or a type R thermocouple. The temperature effect on the thermocouple is such that for successful operation with the recorder, the probe temperature must be greater than 700°C.

The probe output obeys a law, described by the Nernst oxygen equation:

$$E = 0.0496 \times T \times \log \frac{P_1}{P_2} \text{ or, re-written, } P_2 = \frac{P_1}{10^{\frac{E}{0.0496 \times T}}}$$

where,
 P2 = Partial pressure of oxygen in the sampled gas (%)
 P1 = Partial pressure of oxygen in the reference atmosphere (%) (20.95 for air)
 E = Electromotive force across the probe, in mV
 T = Probe temperature in Kelvins.

In order to obtain a useful result, it is necessary to scale the inputs and outputs correctly. The channel measuring the probe voltage will normally need a scale of 0 to 100 mV. The temperature measuring channel will probably be scaled at 300 to 1800 K, whilst the output scaling would typically be 0 to 5% for boiler flues and 0 to 20% in kilns.

OXYGEN POTENTIAL MEASUREMENT

The oxygen potential of an atmosphere is a measure of its ability to oxidise or to reduce. For any element, a value of oxygen potential (free energy of formation) is known, and above this value the material will oxidise, below it, no oxidation will occur.

Oxygen potential is given by the equation:

$$Op = 0.00457 \times T \times \log Op'$$

where,
 Op = Required oxygen potential (kilocalories)
 T = Probe temperature (Kelvin)
 Op' = Partial pressure of oxygen in the reference atmosphere in atmospheres.

It can be shown that, because the oxygen potential of air is essentially constant over the temperature range 873 to 1473 K the probe output is proportional to the oxygen potential of an atmosphere according to:

$$E = (10.84 \times T) + 40 \text{ mV between 873 and 1473K}$$

Thus, it is possible to measure oxygen potential directly from a Zirconia probe, using a standard input channel of the recorder, scaled in units of Oxygen potential.

A typical input range would be 40 to 1124 mV, with a scale of 0 to - 100 kilocalories. Such scaling would be appropriate over the temperature range 873 to 1473 Kelvins.

5.3.4 EQUATIONS (Cont.)

SWITCH

This function copies one of two input or derived channels' values according to the state of its 'Select channel B for Dnn' job. I.E. if a relevant switch job is active, copy the value of source channel B, otherwise copy the value of source channel A.

HIGH SELECT

This function has two input or derived channels as sources, and copies whichever has the higher value at the time.

LOW SELECT

This function has two input or derived channels as sources, and copies whichever has the lower value at the time.

STOPWATCH

The stopwatch starts counting as soon as the function is configured. **The value is normally displayed in as a number of 1/4 seconds, but if one of the date / time formats described in section 5.3.1 is selected, the value is displayed in hours/minutes/seconds.** The stopwatch can be disabled by a maths pack 'job', and can also be reset to zero.

TIME STAMP

When triggered by a maths pack 'job' becoming active, the time stamp reads the current time and date from the system clock and holds it. The time or the date can be displayed, according to the configured value format.

Note: The display format selected affects only the value displayed, not the internal value of the channel. This internal value is a number of seconds, either elapsed since enabled (stopwatch) or elapsed since 1st of January 1988 (Time Stamp). This allows time functions to be processed in the maths pack. For example, two channels, each with a time stamp as its value can be subtracted to give the time between the two time stamps, and this can be displayed as elapsed time if so configured in the Value Format page.

SECTION 6: SERVICE.

LIST OF CONTENTS

Section	Page
6.1 CHART ILLUMINATION TUBE REPLACEMENT	6 - 2
6.2 BATTERY REPLACEMENT	6 - 2

Refer to the Technical Manual for full servicing and maintenance details.

6.1 CHART ILLUMINATION TUBE REPLACEMENT

WARNING

THE RECORDER SHOULD BE ISOLATED FROM MAINS (LINE) POWER BEFORE ANY ATTEMPT IS MADE TO REPLACE THE FLUORESCENT TUBE USED FOR CHART ILLUMINATION.

WARNING

THE EXHAUSTED TUBE MUST BE DISPOSED OF CAREFULLY. SHOULD THE TUBE BREAK, INHALATION OF THE FLUORESCENT POWDERY MATERIAL ON THE INSIDE OF THE TUBE SHOULD BE AVOIDED.

Isolate the recorder from line power, open the recorder door, and remove the plastic cover/reflector which surrounds the fluorescent tube.

Rotate the tube 90° and pull it 'away' from the door, out of its end connections, and dispose of carefully.

Rotate the new tube such that the pins at each end will enter the connectors located at the door.

Carefully push the tube home, and rotate the tube 90°*. Spring the plastic cover / reflector into place. Re-apply mains (line) power, switch the recorder on, close the door and check that the chart illumination is working.

* CAUTION

THE TUBE MUST BE ROTATED 90°, OTHERWISE A HEATER CIRCUIT WILL NOT BE COMPLETED, LEADING TO THE EARLY FAILURE OF THE TUBE.

6.2 BATTERY REPLACEMENT

Replacement battery assemblies are available from the manufacturer.

At the rear of the recorder, remove the battery cover, and with power applied to the recorder (see note 2 below), disconnect the battery pack, and fit the replacement.

Re-fit the battery cover.

Notes:

1. The connector is polarised, so reverse connection is not possible.
 2. Clock and totaliser/counter/timer data will be lost if the battery is changed with power removed from the recorder.
-

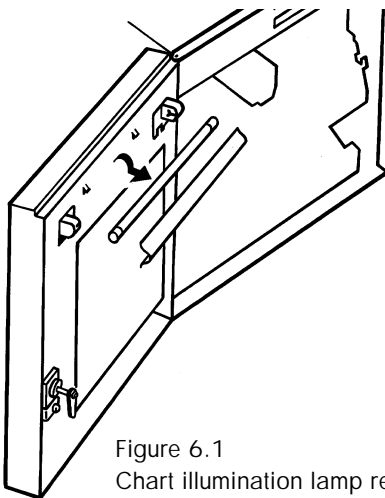

Figure 6.1
Chart illumination lamp replacement

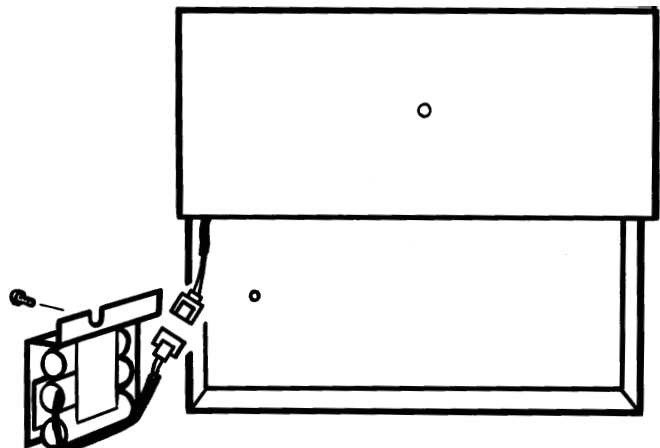

Figure 6.2 Battery replacement

SECTION 7 : REFERENCE.

LIST OF CONTENTS

Section	Page
7.1 RECORDER MESSAGES	7 - 2
FAILURE TO ADJUST	7 - 2
FAILURE TO CALIBRATE	7 - 2
FAILURE TO REMOVE ADJUSTMENT OR CALIBRATION	7 - 2
INVALID INDEX	7 - 3
INVALID CONFIGURATION	7 - 3
PRINTER MUST BE ON LINE	7 - 3
PRINTER MUST BE OFF LINE	7 - 3
CONFIGURATION DISABLED BY COMMS	7 - 3
7.2 COSHH DATA	7 - 4
7.2.1 Printhead inks	7 - 4
7.2.2 Nickel-cadmium batteries	7 - 6
7.3 LIST OF EFFECTIVE PAGES	7 - 8
7.4 GLOSSARY OF TERMS	7 - 9

7.1 RECORDER MESSAGES

This section gives interpretations for messages, which appear at the display for the guidance of the user. The messages are 'fleeting', i.e they appear for approximately 3 seconds, before the previous display page is re-called.

FAILURE TO ADJUST

This message appears during input adjust procedure (section 4.14.1) if the channel being adjusted is not an analogue input type, or if there is a hardware or an internal communications failure within the recorder. If the channel is definitely an analogue input, a service engineer should be contacted.

```
Failed to adjust channel NN  
CONTINUE
```

Operation of the CONTINUE key will call any further channels for which the adjustment failed. When all channels have appeared, the adjustment complete message appears:

```
Adjustment procedure complete
```

FAILURE TO CALIBRATE

This message appears during the input calibration procedure (section 4.14.3) if the channel being calibrated is not an analogue input type, if there is a hardware or internal communications failure within the recorder or if the calibration limits are exceeded. The message also appears during CJ calibration, if the associated channel input type is not a thermocouple. The configuration of the channel should be checked, and if correct, a service engineer should be contacted.

```
Failed to calibrate channel NN  
CONTINUE
```

Operation of the CONTINUE key will call any further channels for which the calibration failed. When all channels have appeared, the calibration complete message appears:

```
Calibration procedure complete
```

```
CJ Calibration procedure complete
```

FAILURE TO REMOVE ADJUSTMENT OR CALIBRATION

This message appears if an attempt is made to remove an adjustment or calibration previously entered (sections 4.14.1 and 4.14.3), if the input channel has been switched off or removed, if a hardware or internal communications failure has appeared or if the channel is not an analogue input type.

```
Failed to remove adjustment on ch NN
```

```
Failed to return ch NN to factory cal
```

7.1 RECORDER MESSAGES (Cont.)

INVALID INDEX

This message appears if a channel / totaliser etc. number is entered which is greater than the maximum number of channels / totalisers etc. fitted.

```
Invalid index
```

INVALID CONFIGURATION

This message appears if one part of the configuration conflicts with another e.g. if the linearisation type does not match the input type.

```
Invalid configuration
```

PRINTER MUST BE ON LINE

This message appears if a 'Quick Scale Print' (section 3.2.2) is requested with the printer off line. The operator CHART category must be entered (also section 3.2.2), and the chart switched on-line.

```
Printer must be on line
```

PRINTER MUST BE OFF LINE

This message appears if chart calibration (section 4.14.2) or configuration print (section 4.15) is requested with the printer on line. The operator CHART category must be entered (section 3.2.2), and the chart switched off- line.

```
Printer must be off line
```

CONFIGURATION DISABLED BY COMMS

This message appears if an attempt is made to enter configuration after a 'DP' command mnemonic has been received by the recorder over the serial communications link. Configuration may not be entered until an 'EP' command mnemonic has been received. See Communications manual for details.

```
Configuration access disabled by comms
```

7.2 COSHH DATA

7.2.1 Printhead inks

Product: Water based inks not containing Formamide			
Part numbers: LA248163 LA249556			
HAZARDOUS INGREDIENTS			
Name	% Range	TLV	Toxicological data
Acid dye	1 to 4	Not available	Not applicable
PHYSICAL DATA			
Boiling point	>212 ° C	Specific gravity	1.05 to 1.1
Vapour pressure	<20 mm Hg	Solubility in water	Complete
Odour	None	Colours	Various
FIRE AND EXPLOSION DATA			
Flash point (deg C) (Method used)	Not flammable		FLAMMABLE LIMIT
Extinguishing media	Use medium appropriate to primary cause of fire.		LEL Not available
			UEL Not available
Special fire-fighting procedures	None		
Unusual fire and explosion hazards	None		
HEALTH HAZARD DATA			
Threshold limit value	Not established		
LD 50 Oral	> 5g/kg	LD 50 Dermal	Not available
Skin and eye irritation	None in normal use		
Over-exposure effects	Slight irritation of mucus membrane		
Chemical nature	Solution of dyestuffs in water and organic solvents		

7.2.1 PRINHEAD INKS (Cont.)

HEALTH HAZARD DATA (Cont.)			
FIRST AID PROCEDURES			
Eyes and skin	Flush affected areas with water. If irritation develops, consult a physician.		
Ingestion	Dilute with water and induce vomiting. Obtain immediate medical assistance.		
Inhalation	If inhaled, move to fresh air.		
REACTIVITY DATA			
STABILITY			Conditions to avoid Strong oxidising agents and temperatures above 90°C
Stable	Yes	Unstable	
Hazardous decomposition products	None		
Hazardous polymerisation	Will not occur		
SPILL OR LEAK PROCEDURES			
Wipe up spills with towels and cloths. Remove stains with soap solution.			
Dispose of waste in accordance with local environment control regulations			
SPECIAL PROTECTION INFORMATION			
Respiratory	None		
Ventilation	Normal ventilation is adequate		
Protective clothing	Use gloves when handling printheads to avoid stains on skin/clothing		
Other	When printheads are being used for recording purposes, there are no known deleterious effects arising from the inks or pen tips.		

7.2.2 Nickel-cadmium batteries

Product: BATTERY PACK (SEALED NICKEL-CADMIUM BATTERIES)			
Part numbers: PA244816			
HAZARDOUS INGREDIENTS			
Name	% Range	TLV	Toxicological data
Negative electrode (cadmium metal, cadmium hydroxide, nickel sinter)	Not established	Not established	Highly toxic
Positive electrode (nickel hydroxide, cobalt hydroxide, nickel sinter)	Not established	Not established	Highly toxic if ingested
Electrolyte (potassium hydroxide)	30 to 45%	Not established	Highly toxic iHighly corrosive
PHYSICAL DATA			
Boiling point	N/A	Specific gravity	N/A
Vapour pressure	N/A	Solubility in water	N/A
Odour	N/A	Colours	N/A
FIRE AND EXPLOSION DATA			
Flash point (deg C) (Method used)	N/A		FLAMMABLE LIMIT
Extinguishing media	Any		LEL N/A
			UEL N/A
Special fire-fighting procedures	N/A		
Unusual fire and explosion hazards	Batteries can explode due to excessive pressure build-up which might not be self-venting. Toxic fumes (cyanogen) may be generated.		
HEALTH HAZARD DATA			
Threshold limit value	N/A		
LD 50 Oral	N/A	LD 50 Dermal	N/A
Skin and eye irritation	If cells leak, the leak material will be a caustic solution. Avoid contact.		
Over-exposure effects	N/A		
Chemical nature	See above. There are no risks in normal use		

7.2.2 NICKEL-CADMIUM BATTERIES (Cont.)

HEALTH HAZARD DATA (Cont.)			
FIRST AID PROCEDURES			
Eyes and skin	If leakage occurs, wash the affected area with plenty of water and cover with dry gauze. If affected, wash eyes with plenty of water. Seek medical assistance.		
Ingestion	If leakage occurs, do NOT induce vomiting. Give plenty of milk to drink. Obtain immediate medical assistance, stating 'nickel cadmium battery'.		
Inhalation	N/A		
REACTIVITY DATA			
STABILITY			Conditions to avoid
Stable	Yes	Unstable	Mechanical damage, overcharging, shorting terminals. Storage temperatures outside the range 0 to 40 deg C.
Hazardous decomposition products	None		
Hazardous polymerisation	Will not occur		
SPILL OR LEAK PROCEDURES			
In normal conditions of use, there is no risk of leakage unless batteries are abused. Abuse can lead to the leaking of a caustic alkaline solution which corrodes aluminium and copper. The leak material should be neutralised by a weak acidic solution such as vinegar, or washed away with copious amounts of water.			
CONTACT SHOULD BE AVOIDED			
SPECIAL PROTECTION INFORMATION			
Respiratory	N/A		
Ventilation	N/A		
Protective clothing	N/A		
Other	In addition to the electrolyte (potassium hydroxide), nickel-cadmium batteries contain cadmium, cadmium hydroxide and nickel hydroxide all of which are highly toxic.		

7.3 LIST OF EFFECTIVE PAGES

This (issue 10) manual consists of the following pages at their stated issue numbers.

Section i		Section3(Cont.)		Section3(Cont.)	
Page i - 1	Issue 10 Nov 98	Page 3 - 19	Issue 9 Jly 98	Page 5 - 6	Issue 9 Jly 98
Page i - 2	Issue 10 Nov 98	Page 3 - 20	Issue 9 Jly 98	Page 5 - 7	Issue 9 Jly 98
Page i - 3	Issue 10 Nov 98	Section 4		Page 5 - 8	Issue 9 Jly 98
Page i - 4	Issue 10 Nov 98	Page 4 - 1	Issue 10 Nov 98	Page 5 - 9	Issue 9 Jly 98
Section 1		Page 4 - 2	Issue 10 Nov 98	Page 5 - 10	Issue 9 Jly 98
Page 1 - 1	Issue 10 Nov 98	Page 4 - 3 / 4	Issue 10 Nov 98	Page 5 - 11	Issue 9 Jly 98
Page 1 - 2	Issue 10 Nov 98	Page 4 - 5	Issue 10 Nov 98	Page 5 - 12	Issue 9 Jly 98
Page 1 - 3	Issue 10 Nov 98	Page 4 - 6	Issue 10 Nov 98	Page 5 - 13	Issue 9 Jly 98
Page 1 - 4	Issue 10 Nov 98	Page 4 - 7	Issue 10 Nov 98	Page 5 - 14	Issue 9 Jly 98
Page 1 - 5	Issue 10 Nov 98	Page 4 - 8	Issue 10 Nov 98	Page 5 - 15	Issue 9 Jly 98
Page 1 - 6	Issue 10 Nov 98	Page 4 - 9	Issue 10 Nov 98	Page 5 - 16	Issue 9 Jly 98
Page 1 - 7	Issue 10 Nov 98	Page 4 - 10	Issue 10 Nov 98	Page 5 - 17	Issue 9 Jly 98
Page 1 - 8	Issue 10 Nov 98	Page 4 - 11	Issue 10 Nov 98	Page 5 - 18	Issue 9 Jly 98
Page 1 - 9	Issue 10 Nov 98	Page 4 - 12	Issue 10 Nov 98	Page 5 - 19	Issue 9 Jly 98
Page 1 - 10	Issue 10 Nov 98	Page 4 - 13	Issue 10 Nov 98	Page 5 - 20	Issue 9 Jly 98
Page 1 - 11	Issue 10 Nov 98	Page 4 - 14	Issue 10 Nov 98	Section 6	
Page 1 - 12	Issue 10 Nov 98	Page 4 - 15	Issue 10 Nov 98	Page 6 - 1	Issue 9 Jly 98
Section 2		Page 4 - 16	Issue 10 Nov 98	Page 6 - 2	Issue 9 Jly 98
Page 2 - 1	Issue 9 Jly 98	Page 4 - 17	Issue 10 Nov 98	Section 7	
Page 2 - 2	Issue 9 Jly 98	Page 4 - 18	Issue 10 Nov 98	Page 7 - 1	Issue 10 Nov 98
Page 2 - 3	Issue 9 Jly 98	Page 4 - 19	Issue 10 Nov 98	Page 7 - 2	Issue 10 Nov 98
Page 2 - 4	Issue 9 Jly 98	Page 4 - 20	Issue 10 Nov 98	Page 7 - 3	Issue 10 Nov 98
Page 2 - 5/6	Issue 9 Jly 98	Page 4 - 21	Issue 10 Nov 98	Page 7 - 4	Issue 10 Nov 98
Page 2 - 7	Issue 9 Jly 98	Page 4 - 22	Issue 10 Nov 98	Page 7 - 5	Issue 10 Nov 98
Page 2 - 8	Issue 9 Jly 98	Page 4 - 23	Issue 10 Nov 98	Page 7 - 6	Issue 10 Nov 98
Page 2 - 9	Issue 9 Jly 98	Page 4 - 24	Issue 10 Nov 98	Page 7 - 7	Issue 10 Nov 98
Page 2 - 10	Issue 9 Jly 98	Page 4 - 25	Issue 10 Nov 98	Page 7 - 8	Issue 10 Nov 98
Page 2 - 11	Issue 9 Jly 98	Page 4 - 26	Issue 10 Nov 98	Page 7 - 9	Issue 10 Nov 98
Page 2 - 12	Issue 9 Jly 98	Page 4 - 27	Issue 10 Nov 98	Page 7 - 10	Issue 10 Nov 98
Page 2 - 13	Issue 9 Jly 98	Page 4 - 28	Issue 10 Nov 98	Page 7 - 11	Issue 10 Nov 98
Page 2 - 14	Issue 9 Jly 98	Page 4 - 29	Issue 10 Nov 98	Page 7 - 12	Issue 10 Nov 98
Page 2 - 15	Issue 9 Jly 98	Page 4 - 30	Issue 10 Nov 98	Annex A	
Page 2 - 16	Issue 9 Jly 98	Page 4 - 31	Issue 10 Nov 98	Page A - 1	Issue 10 Nov 98
Page 2 - 17	Issue 9 Jly 98	Page 4 - 32	Issue 10 Nov 98	Page A - 2	Issue 10 Nov 98
Page 2 - 18	Issue 9 Jly 98	Page 4 - 33	Issue 10 Nov 98	Page A - 3	Issue 10 Nov 98
Section 3		Page 4 - 34	Issue 10 Nov 98	Page A - 4	Issue 10 Nov 98
Page 3 - 1	Issue 9 Jly 98	Page 4 - 35/36	Issue 10 Nov 98	Page A - 5	Issue 10 Nov 98
Page 3 - 2	Issue 9 Jly 98	Page 4 - 37	Issue 10 Nov 98	Page A - 6	Issue 10 Nov 98
Page 3 - 3 / 4	Issue 9 Jly 98	Page 4 - 38	Issue 10 Nov 98	Page A - 7	Issue 10 Nov 98
Page 3 - 5	Issue 9 Jly 98	Page 4 - 39/40	Issue 10 Nov 98	Page A - 8	Issue 10 Nov 98
Page 3 - 6	Issue 9 Jly 98	Page 4 - 41	Issue 10 Nov 98	Annex B	
Page 3 - 7	Issue 9 Jly 98	Page 4 - 42	Issue 10 Nov 98	Page B - 1	Issue 10 Nov 98
Page 3 - 8	Issue 9 Jly 98	Page 4 - 43	Issue 10 Nov 98	Page B - 2	Issue 10 Nov 98
Page 3 - 9	Issue 9 Jly 98	Page 4 - 44	Issue 10 Nov 98	Page B - 3	Issue 10 Nov 98
Page 3 - 10	Issue 9 Jly 98	Page 4 - 45	Issue 10 Nov 98	Page B - 4	Issue 10 Nov 98
Page 3 - 11	Issue 9 Jly 98	Page 4 - 46	Issue 10 Nov 98	Page B - 5	Issue 10 Nov 98
Page 3 - 12	Issue 9 Jly 98	Section 5		Page B - 6	Issue 10 Nov 98
Page 3 - 13	Issue 9 Jly 98	Page 5 - 1	Issue 9 Jly 98	Index	
Page 3 - 14	Issue 9 Jly 98	Page 5 - 2	Issue 9 Jly 98	Page i	Issue 9 Jly 98
Page 3 - 15	Issue 9 Jly 98	Page 5 - 3	Issue 9 Jly 98	Page ii	Issue 9 Jly 98
Page 3 - 16	Issue 9 Jly 98	Page 5 - 4	Issue 9 Jly 98	Page iii	Issue 9 Jly 98
Page 3 - 17	Issue 9 Jly 98	Page 5 - 5	Issue 9 Jly 98	Page iv	Issue 9 Jly 98
Page 3 - 18	Issue 9 Jly 98				

7.4 GLOSSARY OF TERMS

The following glossary is general to all the manufacturer's products and may thus contain terms which are not applicable to your particular unit. In particular, many of the terms are relevant only to configurable recorders.

Alarm	A function which is triggered when an <i>input signal</i> or a signal derived from it reaches a certain value (absolute or deviation alarms) or changes faster than a specified rate (rate-of-change alarms) or changes state (digital alarms). Once triggered, the alarm can initiate a <i>job list</i> , such as causing a <i>relay output</i> to change state, sounding a buzzer, changing chart speed etc.
Analogue input	An input which changes in a smooth (non-stepped) way (e.g. thermocouples, resistance thermometers).
Analogue output	An output from the recorder which is a scaled and linearised copy of an <i>analogue input</i> or <i>derived channel</i> . Also called retransmission output.
Attenuator	A resistive device which reduces the signal voltage by a known ratio (usually 100:1)
Break response	The recorder can detect an open circuit at its input terminals. As a part of the channel configuration, the instrument's response to an open circuit can be defined as 'None', 'Drive high' or 'Drive low'. If 'none' is selected the trace is allowed to drift according to what the input wiring is picking up (acting as an aerial). Drive high (low) causes the trace to be drawn at the extreme right (left) side of the chart.
Chart cassette	A mechanical paper transport system for containing and feeding the chart past the <i>pens</i> or <i>printhead</i> at a known speed. The cassette includes reservoirs for unused (pay-out tray) and used (take-up tray) sections of chart.
Cold Junction Compensation	Also known by the abbreviation CJC. The voltage generated by a <i>thermocouple</i> (TC) junction depends on the temperature difference between the actual bonded junction (the hot junction), and the other (non-bonded) end of the conductors (the cold junction (CJ)). Thus, for any reading from a TC to be accurate, the temperature of the CJ must be taken into account. This can be done in three ways: Internal, External or Remote. <u>Internal</u> . The recorder has integral temperature detectors measuring the temperature near the terminal blocks (the cold junction for directly connected TCs). <u>External</u> . For remote TCs, the cold junction can be held at a known temperature. This temperature is entered (in degrees) as a part of the CJC configuration. <u>Remote</u> . For remote TCs, an auxiliary temperature detector can be used to measure the cold junction temperature. This detector is then connected to a separate input channel. This input channel number is entered as a part of the CJC configuration.
Communications	Most recorders now offer a 'Serial Communications' option to allow a computer (PC) to communicate directly with one or more recorders in order to <i>configure</i> them, or to read information from them regarding the <i>process variables</i> being measured.
Configuration	This is used as a verb to mean 'the process of telling your recorder what you want it to do', and as a noun to mean 'the way in which the recorder has been set up (or configured)'. Recorders fitted with <i>memory card</i> or <i>communications</i> options can save their configuration to the memory card or to the host computer. This ensures against loss, and also allows configurations to be copied from one recorder to another.
Continuous trace	This is used to describe recorders which have a single <i>pen</i> associated with each <i>process variable</i> , and this pen <i>traces</i> the value continuously. See also multipoint recorder.
Counters	Counters can be incremented or decremented by digital/discrete inputs or by <i>job list</i> action. Counters can be preset. Each counter can have a set point which triggers a <i>job list</i> when the counter value passes through the set point either incrementing (High) or decrementing (Low).

Data acquisition	A general term describing the successful reading of an input signal. The term Data Acquisition Unit describes those units which are able to read input signals and act upon them (<i>alarms retransmission</i> maths functions etc) without necessarily having the facility of displaying or recording them.
Derived channel	A 'pseudo' channel which contains the results of maths pack operations so they can be traced on the chart, logged etc.
Derived Variable (DV)	The result of one or more <i>input channel</i> or <i>derived channel</i> being acted upon by a <i>mathematical function</i> (e.g. Channel average).
Digital (discrete) input	An input which has only two states (on or off). Examples are switch inputs or voltage pulse inputs.
Event input	A discrete (switch) or digital (voltage level) input. When active, an event input can initiate a <i>job list</i> .
Graphics recorder/unit	A recorder or display unit which uses a touch-sensitive liquid crystal display both as its operator interface, and to display traces as though on a chart. Recorders can come with or without charts; chartless recorders using electronic storage rather than paper to save information.
Hysteresis	When an <i>input signal</i> is 'hovering' near a <i>setpoint</i> , then an annoying and potentially damaging series of <i>alarms</i> can be generated, instead of just one alarm which can be acknowledged and the cause dealt with if necessary. To avoid this, a 'hysteresis' value can be entered in the alarm configuration, which effectively puts a dead band round the set point. For example an absolute high alarm with a set point of 100 and a hysteresis value of 10, would be triggered when the input signal value rose above 100, but would not re-trigger again until after the alarm had been 'cleared' by the process value falling below 90. An attempt to depict this example is given in the figure below.

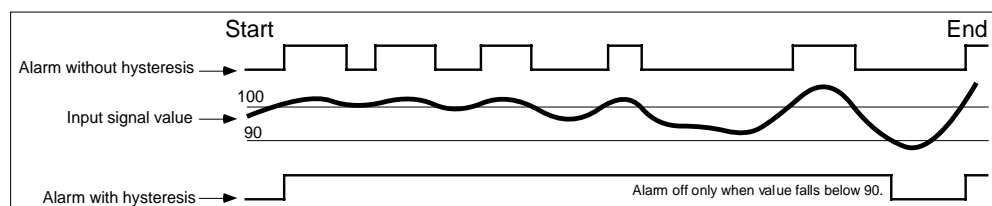

Input channel	An input circuit which accepts voltage, current or digital <i>input signals</i> from the user.
Input signal	A voltage, current or digital input applied to the recorder input circuits. See also Analogue input and Digital (discrete) input.
Job list	A set of actions to be carried out by the recorder, when the job list becomes active. Typical 'jobs' are to activate a <i>relay</i> , display a message, change chart speed etc.
Linearisation table	Most <i>transducers</i> produce an output which is not directly proportional to the input. For example, the voltage output from a <i>thermocouple</i> does not vary linearly with the temperature it is exposed to. The recorder uses a 'look-up' table to find a temperature value for any mV input from a specified thermocouple type. Similar tables exist for other transducers such as <i>resistance thermometers</i> . In most modern instruments, the user can enter one or more tables of his/her own.
Log	Logging allows <i>process variable</i> values to be printed numerically in tabular form on the chart. Alternatively, logs can be sent to the <i>memory card</i> (if fitted).
Mathematical function	With the maths pack option(s) fitted, a number of mathematical functions become available to the user. For example, you may want to look at the difference between two <i>input signals</i> , in which case a simple Subtract function would be used. The resulting <i>Derived Variable</i> can be traced, using a <i>derived channel</i> , or could be used to trigger a <i>job list</i> if the difference between the two input signal became too great or too small, and so on. A complete list of functions is given below, but not all are available on all instruments.

Maths functions (Cont.)

Constant	Square root	Log base 10	Latching maximum	Switch
Copy	Channel average	Rate of change	Continuous maximum	High select
Add	Group average	Sample and hold	Polynomial	Low select
Subtract	Rolling average	Channel minimum	Relative humidity	Trace generator
Multiply	Exponent	Latching minimum	Linear mass flow	Stopwatch
Divide	Natural log	Continuous minimum	Square root mass flow	Time stamp
Modulus	10 ^X	Channel maximum	Zirconia probe	F value

Measured value	An umbrella term which means: the value of an <i>input channel</i> , <i>derived channel</i> , <i>totaliser</i> , <i>counter</i> , <i>timer</i> etc. measured in mathematical units as a proportion of the <i>span</i> . See also Process variable.
Memory card	Used to describe SRAM (Static Random Access Memory) solid state memory cards, or portable hard or floppy disks, used to record <i>configurations</i> , data etc. which can then be taken to a remote PC for further analysis, if required.
Multipoint recorder	This is used to describe recorders which have multiple pen <i>printheads</i> rather than individual pens to produce the <i>trace</i> on the chart. Each trace is made up of dots, produced by the print-head as it traverses across the chart at regular intervals. Advantages are that many more traces can be laid down on the chart, the traces can be annotated for identification and messages can be printed on the chart. Disadvantages are that fast transients may be missed at low chart speeds.
Operator interface	A term used to describe the controls (e.g. pushbuttons, keypads) and visual feedback (display) that are used to operate and configure the unit.
Paper transport system	This includes the <i>chart cassette</i> and the mechanical system, motors etc. needed to move the chart through the cassette. The paper transport system is often considered to be an integral part of the <i>writing system</i> .
Pen	A fibre-tipped disposable stylus with an integral ink reservoir. Used to draw (trace) the value of a single process variable on the chart in <i>continuous trace</i> recorders.
Pen offset compensation	With most <i>continuous trace</i> recorders, the mechanical positions of the pen tips are offset, in the time axis, in order that they do not collide with one another as they traverse the chart. A result of this is that simultaneous events in more than one channel can appear to be very far from simultaneous, particularly at slow chart speeds. To overcome this apparent time difference, most recorders now offer pen offset compensation, which delays the signals of all but the final channel. This has the disadvantage that changes may not appear on the chart until a considerable time after they have happened.
Pen tray	With modular recorder designs, each <i>pen</i> has its own mechanical system (including motor and feedback device) associated with it too drive it backwards and forwards across the chart. Pen tray is the general term for such mechanical systems. With some recorders, the pen drive electronics are integral with the pen tray.
Printhead	This is a device which, together with a disposable multi-colour cartridge, allows multi-point recorders to mark the chart.
Process variable	An umbrella term which means: the value of an <i>input channel</i> , <i>derived channel</i> , <i>totaliser</i> , <i>counter</i> , <i>timer</i> etc. measured in engineering units (e.g. Degrees Celsius). See also Measured value.
Relay output	A set of contacts which changes state as a result of a <i>job list</i> being run. Relays are energised continuously except when 'in alarm', so that if power to the recorder fails they go into their 'alarm' state.
Resistance thermometer	Also known as a resistance temperature detector (RTD), a resistance thermometer is constructed of a material whose resistance varies in a known way on the temperature it is exposed to. The resistance variation is non-linear, but for any given type, this non-linearity is well known and invariable and is compensated for by <i>linearisation tables</i> in the recorder memory.

Retransmission output	See Analogue output.
Setpoint	Also known as ‘threshold’, this is the point at which an <i>alarm</i> becomes active or inactive. See also <i>hysteresis</i> .
Shunt	The input circuit of each recorder channel measures voltage signals. If current signals are connected to the recorder, a low value resistor must be placed across the inputs, to convert the current signal to Volts, according to Ohms law (Volts = Amps x Ohms). Thus, a 0 to 20 mA (0.02 Amps) signal applied across a 250 Ω resistor produces a voltage range of 0 to (0.02 x 250) Volts = 5 Volts. Such resistors are called ‘Shunt resistors’ or ‘Shunts’ for short, and are usually of very close tolerance.
Span	Span has two common meanings: the right-most grid of the chart, or the value given by (maximum value - minimum value). The two meanings are identical where the minimum value is zero.
Trace	The line produced on the chart or display screen showing the value of the <i>process variable</i> being measured.
Thermocouple	A junction of two dissimilar metals which produces a small voltage, the value of which depends on the temperature of the junction. The voltage varies in a non-linear way with temperature, but for any given type, this non-linearity is well known and invariable and is compensated for by <i>linearisation tables</i> in the recorder memory.
Threshold	See setpoint.
Timer	Timers carry out general timing functions, and can initiate <i>job lists</i> .
Totaliser	A mathematical function which allows flow rates (e.g. cubic feet per second) to be converted to actual quantities (e.g. cubic feet).
Transducer	A device which produces an electrical output proportional to temperature, flow rate, pressure, speed, position etc. Common transducers are potentiometers, <i>thermocouples</i> , <i>resistance thermometers (RTDs)</i> and flow meters.
Transmitter	Thermocouple wire (compensation wire) is expensive, and if the thermocouple is a long way from the measuring device, it is often cheaper to instal a ‘transmitter’ local to the thermocouple. This device converts the mV signal from the thermocouple to a mA signal which can then be wired to the recorder using normal copper wire. Transmitters can be self powered, or they may need power generated for them. Most recorders can be fitted with Transmitter Power Supplies as an option.
Writing system	A general term used to describe the mechanical means of moving <i>pens/printheads</i> across the chart width. The term often includes the paper transport system used to drive the chart through the cassette.
Zero	Zero is generally taken to mean the value associated with the left-most grid line on the chart. Its actual value need not be zero, as long as it is less than the Span value.

ANNEX A: RECORDER SPECIFICATION

LIST OF CONTENTS

Section	Page
A1 GENERAL SPECIFICATION	A - 2
A2 UNIVERSAL 8-CHANNEL INPUT BOARD SPECIFICATION	A - 4
A3 16-CHANNEL DC INPUT BOARD SPECIFICATION	A - 6
A4 RELAY OUTPUT BOARD SPECIFICATION	A - 7

INSTALLATION CATEGORY AND POLLUTION DEGREE

This product has been designed to conform to BS EN61010 installation category II and pollution degree 2. These are defined as follows:

INSTALLATION CATEGORY II

The rated impulse voltage for equipment on nominal 230V ac mains is 2500V.

POLLUTION DEGREE 2

Normally, only non-conductive pollution occurs. Occasionally, however, a temporary conductivity caused by condensation shall be expected.

ANNEX A

RECORDER SPECIFICATION

A1 GENERAL SPECIFICATION

I/O board types

Input	8-channel universal input; 16-channel dc input
Output	8-channel relay output, 4 channel analogue output, 8 channel analogue output
Max number of I/O boards per type	3 off 8-channel input, 3 off relay output; 3 off 16-channel input; 3 off analogue output
Max number of inputs	48 dc inputs*; 24 resistance inputs; 39 contact closure.
Max number of outputs	Relays: 8 x no of free slots.
	Analogue outputs: 8
Maximum number of traced channels	24 total input/derived.

Environmental Performance

General	To BS2011: 1981
Temperature limits	Operation: 0 to + 50 °C Storage: -20 to +70 °C
Humidity limits	Operation: 5 to 80% RH; non-condensing Storage: 5 to 90% RH; non-condensing
Max. altitude	< 2000 metres
Protection	IP54 (door and bezel); IP31 (sleeve).
Shock	BS EN61010 1990 (safety); IEC 873: 1986
Vibration	BS EN61010 1990 (safety); IEC 873: 1986.

Electromagnetic compatibility (EMC)

Emissions	BS EN50081-2
Immunity	BS EN50082-2

Electrical Safety

To BS EN61010: 1990 Class 1.

Physical

Bezel size	288 mm. high x 288 mm. wide x 45 mm. deep.
Panel cutout size	281 mm high x 281 mm. wide. (+ 1.4 mm. - 0 mm.)
Depth behind bezel rear face	304 mm. (inc. rear cover); 275 mm. (no rear cover)
Weight (Eight-channel instrument)	12.5 kg. max.
Panel mounting angle	Up to ± 30° from vertical.

Performance

Maximum scan and update rate	All parameters in 1 second
Maximum print rate (trending)	24 channels in 3 seconds
Maximum chart speed	1500 mm/hr.
Clock accuracy	Better than 60 ppm.

(Continued)

* DC inputs are defined as Volts, mV, mA, thermocouple and contact closure, but do not include resistance inputs.

A1 GENERAL SPECIFICATION (CONT.)**Printing system**

Method	Printhead with 6 coloured dotting nibs
Colours	Black, brown, red, green, blue, violet
Printhead life	> 1.5 million dots per colour (recorder continuously powered*)
Dot diameter	0.35 to 0.6 mm.
Dot spacing (vertical)	0.25 mm. (chart speed <300 mm/hr.); 0.5 mm (600 mm/hr); 1 mm. (1200 mm/hr.); 1.25 mm (1500 mm/hr)
Dot spacing (horizontal)	0.39 mm.
Characters per line	77
Noise level	55 dBA max. (door closed).
Maximum trending rate	24 channels per pass (3 seconds)

Paper transport

Type	Tractor feed with selectable chart speed from 1 to 1500 mm/hr. (0.4 to 60 inches/hour)
Chart length	22 metres (z-fold - fold depth 75 mm.).
Chart width	224 mm. overall; 180 mm. calibrated.
Pen-to-paper accuracy	0.25% of calibrated chart width.
Transport accuracy	Better than 10 mm. in 22 meters.

Power requirements

Line voltage (45 to 65 Hertz)	90 to 132 Volts or 180 to 264 Volts (User selectable).
Maximum power	70 W
Fuse type	Ceramic 20 mm. 3.15 Amp. Fast blow.
Interrupt protection	100 ms at 50% load.

Memory protection

	EEPROM (for configuration)
	Battery-backed RAM for clock, totalisers etc.
RAM / clock-support battery type	Nickel-Cadmium (rechargeable)
Support period (no power to recorder)	3 months min. at 25 °C; 1 month min. at 50 °C.

* To prolong pen life, it is recommended that the printhead assembly be removed from the recorder if it is to be left unpowered for extended periods.

A2 UNIVERSAL 8-CHANNEL INPUT BOARD SPECIFICATION

General specification

Number of inputs	8
Termination	Edge connector / terminal block
Input types	DC Volts, dc millivolts, dc milliamps (with shunt). Thermocouple, Resistance thermometer (2- or 3-wire), Ohms, Contact closure
Input type mix	User selectable during channel configuration.
Measurement frequency	All channels in 1 second
Step response to within resolution	2 seconds
Noise rejection	Common mode: 150dB above 45 Hz. (channel-channel and channel-ground.) Series mode: 67dB above 45 Hz.
Maximum common mode voltage	250 Volts
Maximum series mode voltage	10 mV at lowest range; 500 mV peak at highest range.
Isolation (dc to 65 Hz; BS EN61010)	Installation category II; Pollution degree 2 (see page A-1 for definitions) 300 V channel-to-channel (double isolation) and channel-to-ground (basic isolation)
Dielectric strength	2350 V ac for 1 minute (channel-channel); 1350V ac (channel-ground)
Insulation resistance	50 M Ω at 500V dc.
Input impedance	>10 M Ω (68.8k Ω for 10V range)
Over-voltage protection	60 Volts peak, 500 V through 50 k Ω resistor
Open cct. detection (to 200 mV range)	65 nA current (max.); 8 seconds recognition time (max.); 10 M Ω minimum break resistance.

DC input ranges

Ranges available	-10 to +40 mV; -50 to 200 mV; -500 mV to +1 V; -5 V to +10V (100V with attenuator)
Temperature performance (worst case)	
-10 to 40 mV	80ppm/°C of reading + 27.9ppm/°C of range
-50 to -200mV	80ppm/°C of reading + 12.4ppm/°C of range
-0.5 to +1V	80ppm/°C of reading + 2.1ppm/°C of range
-5 to +10V	272ppm/°C of reading + 4.7ppm/°C of range
Shunt/Attenuator	Fitting method: Resistor modules mounted on user's terminal block(s) Additional errors: 0.1% (shunt); 0.2% (attenuator)

Range	Resolution	Performance (worst case) in instrument at 20 °C
-10 mV to +40 mV	1.4 μ V	0.083 % reading + 0.056 % range
-50 mV to +200 mV	14 μ V	0.072% reading + 0.073% range
-0.5 V to +1 V	37 μ V	0.070% reading + 0.032% range
-5 to +10 V	370 μ V.	0.223% reading + 0.034% range

Thermocouple data

Linearisation errors	0.15 °C or better
Bias current	<2 nA (<10 nA at 70 °C)
Cold Junction (CJ) types (selectable)	Off, internal, external, remote.
CJ error	0.5 °C or better
CJ rejection ratio	25:1 minimum
Remote CJ	Via any user-selected input channel.
Upscale/downscale drive	Configurable for each channel

T/C type	Range (°C)	Standard
B	+200 to +1800	IEC584.1:1977
C	0 to +2300	Hoskins
E	-200 to +1000	IEC584.1:1977
J	-200 to +1200	IEC584.1:1977
K	-200 to +1370	IEC584.1:1977
L	-200 to +900	DIN 43710
N	-200 to +1300	IEC584.1:1977
R	-200 to +1760	IEC584.1:1977
S	-50 to +1760	IEC584.1:1977
T	-250 to +400	IEC584.1:1977
U	-100 to +600	DIN 43710-85
NiMoNiCo	-50 to +1410	ASTM E1751-95
Platinel II	-100 to +1300	Engelhard R83

Note: Previous versions of the recorder came with NiNiMo linearisation instead of NiMoNiCo.

A2 UNIVERSAL 8-CHANNEL INPUT BOARD SPECIFICATION (CONT.)**3-wire RTD data**

RTD linearisations Pt100, Pt1000, Cu10, Ni100, Ni120

Linearisation errors 0.012 °C or better

Influence of lead resistance error: 0.15 % of lead resistance

mismatch: 1 ohm per ohm.

Types and ranges

RTD type	Range (°C)	Standard
Pt 100	- 200 to + 850	IEC751: 1981
Pt1000	- 200 to + 850	Based on IEC751: 1981
Cu 10	-20 to + 250	General Electric
Ni 100	- 50 to + 170	DIN43760
Ni 120	- 50 to + 170	Based on DIN 43760

Pt100 figures (worst case)

Range °C	Resolution	Performance (worst case) in instrument at 20 °C
- 200 to + 200	0.02 °C	0.033% reading + 0.32 °C
- 200 to + 1000	0.14 °C	0.033% reading + 1.85 °C

Ohms ranges

Ranges 0 to 180Ω; 0 to 1.8kΩ; 0 to 10.0kΩ

Temperature performance (worst case)

0 to 180Ω 35ppm/°C of reading + 34.3ppm/°C of range

0 to 1.8kΩ 35ppm/°C of reading + 14.6ppm/°C of range

0 to 10kΩ 35ppm/°C of reading + 1.9ppm/°C of range

Range	Lead resistance	Resolution	Performance (worst case) in instrument at 20 °C
0 to 180 Ω	10 Ω	5 mΩ	0.033% reading +0.070% range
0 to 1.8 kΩ	10 Ω	55 mΩ	0.033 % reading + 0.041 % range
0 to 10 kΩ	10 Ω	148 mΩ	0.037 % reading + 0.020 % range

Other linearisationsTables available $\sqrt{\text{value}}$; $(\text{value})^{3/2}$; $(\text{value})^{5/2}$; User defined tables (up to 2 off)**Contact closure (switch) inputs**

Type Volt-free contact

Wetting voltage 2.5 Volts nominal

Minimum latched pulse width 125 ms.

De-bounce Inherent 1 second.

A3 16-CHANNEL DC INPUT BOARD SPECIFICATION**General specification**

Number of inputs	16
Termination	Edge connector / terminal block
Input types	DC Volts, dc millivolts, dc milliamps (with shunt), thermocouple, Contact closure (not channels 1, 8, 16)
Input type mix	Software selected on configuration for each channel*.
Measurement frequency	All channels in 1 second
Step response	1.5 seconds
Noise rejection	Common mode: 150dB above 45 Hz. (channel-channel and channel-ground.) Series mode: > 60dB between 10 to 100 Hz.
Maximum series mode voltage	Hardware range +50 mV.
Safety isolation (BS EN61010)	Installation category II, Pollution degree 2 (See page A-1 for definitions) 300 V channel-to-channel (double isolation) and channel-to-ground (basic isolation)
Dielectric strength	2350 V ac continuous (channel-channel); 1350V ac (channel-ground).
Input impedance	> 10 M Ω (68.8k Ω for 5V range)
Over-voltage protection	60 Volts peak, 500 V through 50 k Ω resistor
Open cct. detection (85 mV range only)	65 nA current (max.); 8 seconds recognition time (max.); 40 M Ω minimum break resistance.
Damping	2, 4, 8, 16, 32, 64, 128 or 256 secs. time constant, as configured. Damping improves o/p noise and performance figures listed in the table below.

DC input ranges

Ranges available	-15mV to +85 mV; -1.0 V to +5 V
Temperature performance (worst case)	
-15 to +85mV	80ppm/°C of reading + 12.9ppm/°C of range
-1 to +5V	272ppm/°C of reading + 7.8ppm/°C of range
Shunt	Externally mounted resistor modules
Additional error due to shunt	0.1%.

Range	Resolution	Performance (worst case) in instrument at 20°C
-15 mV to + 85 mV - 1.0V to + 5 V	$\pm 5.5 \mu\text{V}$ $\pm 280\mu\text{V}$	0.072% reading + 0.071% range 0.223% reading + 0.055 range

Thermocouple data (in addition to the above)

Linearisation errors	0.15 °C or better
Bias current	< 2 nA (< 10 nA at 70 °C)
Cold Junction (CJ) types (selectable)	Off, internal, external, remote.
CJ error	1 °C or better
CJ rejection ratio	25:1 minimum
Remote CJ	Via any user-selected input channel.
Upscale drive	Configurable for each channel

Note: Previous versions of the recorder came with NiNiMo linearisation instead of NiMoNiCo.

T/C type	Range (°C)	Standard
B	+ 200 to + 1800	IEC584.1:1977
C	0 to + 2300	Hoskins
E	- 200 to + 1000	IEC584.1:1977
J	- 200 to + 1200	IEC584.1:1977
K	- 200 to + 1370	IEC584.1:1977
L	-200 to + 900	DIN 43710
N	- 200 to + 1300	IEC584.1:1977
R	- 200 to + 1760	IEC584.1:1977
S	- 50 to + 1760	IEC584.1:1977
T	- 250 to + 400	IEC584.1:1977
U	- 100 to + 600	DIN 43710-85
NiMoNiCo	- 50 to +1410	ASTM E1751-95
Platinel II	-100 to + 1300	Engelhard R83

* Maximum of eight different linearisations (seven + linear) allowed per board.

Contact closure inputs not available on channels 1, 8 and 16.

A3 16-CHANNEL DC INPUT BOARD SPECIFICATION (CONT.)

Other linearisations

Tables available $\sqrt{\text{value}}$; $(\text{value})^{3/2}$; $(\text{value})^{5/2}$; User defined tables (up to 2 off)

Contact closure (switch) inputs (not available for channels 1, 8 and 16)

Type	Volt-free contact
Wetting voltage	2.5 Volts nominal
Minimum latched pulse width	250 ms.
De-bounce	Inherent 1 second.

A4 RELAY OUTPUT BOARD SPECIFICATION

No of relays per board	Eight
Contact format	Single pole change-over (single set of common, normally open and normally closed contacts)
Estimated life at 60VA load	1,000,000 operations
Max contact voltage*	250 Volts ac.
Max contact current*	Make: 8 Amps Continuous: 3 Amps Break: 2 Amps
Maximum switchable power*	60 watts or 500 VA
Isolation (BS EN61010)	Installation category II, Pollution degree 2 (see page A-1 for definitions) 250V ac channel-to-channel (double isolation) and channel-to-ground (basic isolation)
Dielectric strength	1350V ac for 1 min. (contact to contact) 2350V ac for 1 min. (channel to channel) 1350V ac for 1 min. (channel to ground)

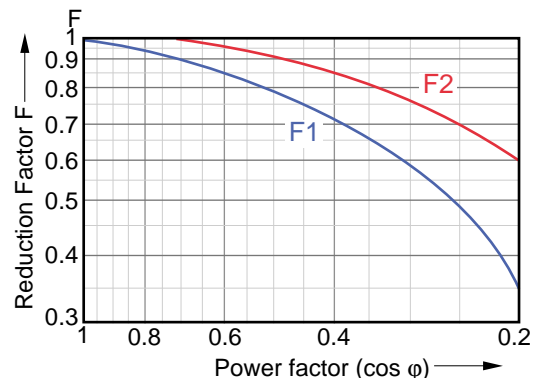

Figure A4 derating curves

* With resistive loads. Derate with reactive or inductive loads according to figure A4 in which:

F1 = measured on representative samples

F2 = typical values (according to experience)

Contact life = resistive life x Reduction factor

A5 ANALOGUE OUTPUT BOARD SPECIFICATION

General specification

Number of outputs	Four or eight as ordered
Termination	Edge connector / terminal block
Output types	Current or Voltage as configured for each channel
	Current: 0 to 25mA max. at up to 24 V
	Voltage: -1 to 11V at up to 5 mA
Output frequency	All channels in 1 second
Output damping	250 msec rise time (10% to 90%)
Resolution	0.025% full scale, monotonic.
Isolation (dc to 65 Hz; BS EN61010)	Installation category II; Pollution degree 2 (See page A1 for definitions)
	Channel to channel: 250V RMS or dc (double isolation)
	Channel-to-ground: 250V RMS or dc (basic isolation)
Dielectric strength (BS EN61010)	(1 minute type tests)
	Channel to channel: 2350 V ac
	Channel to ground: 1350V ac
Insulation resistance	50 MΩ at 500V dc.

This page is deliberately left blank

ANNEX B PREVIOUS RECORDER MODELS

LIST OF CONTENTS

Section	page
B1 INTRODUCTION	B - 3
B2 CHART INSTALLATION / REPLACEMENT	B - 4
B2.1 Old chart removal	B - 4
B2.2 Fitting a new chart	B - 4
B3 PRINT CARTRIDGE REPLACEMENT	B - 6
B3.1 Pen lift bar	B - 6

Notes:

- 1 In order to optimise thermal performance, it is recommended that the recorder be left powered at all times. If trending is not required, the chart drive can be disabled as described in section B2
 2. If the recorder is to be left for an extended period without power applied, it is recommended that the printcartridge be removed from the recorder (section B3) and stored separately, in a sealed container.
 - 3 The instrument can weigh up to 20 kg. It is therefore recommended that a risk assessment be carried out before it is handled.
-

This page is deliberately left blank

SECTION B PREVIOUS RECORDER MODELS

B1 INTRODUCTION

This section includes chart change/ print cartridge replacement procedures for non-current recorders. Such recorders are differentiated from the current recorder, by the appearance of the print cartridge as shown in figure B1 below.

Note: The print cartridges are not physically interchangeable

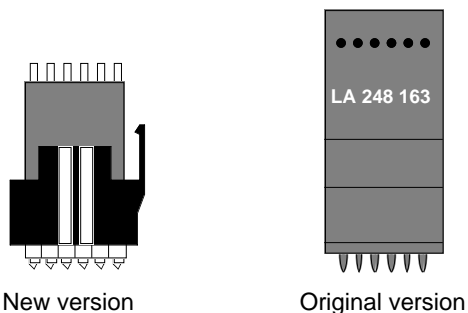
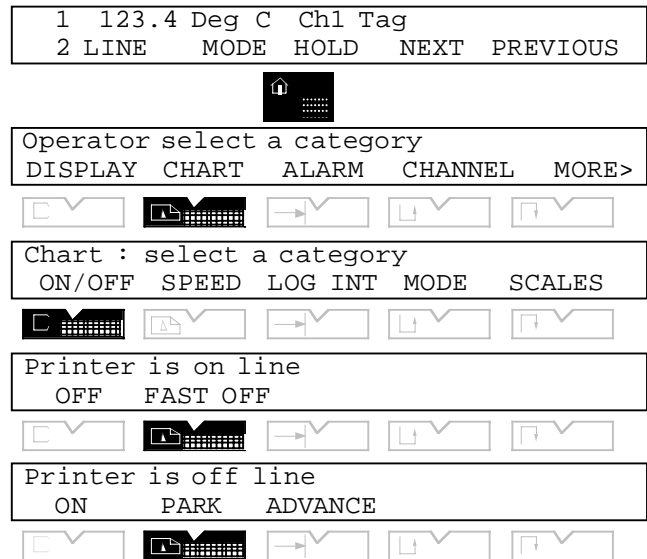

Figure B1 Comparison of print cartridges

B2 CHART INSTALLATION / REPLACEMENT

Before fitting a chart, it is recommended that chart drive is switched off, as follows:

- Operate the 'Home' hard key.
- Operate the 'CHART' softkey.
- Operate the ON/OFF softkey, then the OFF or FAST OFF softkey.
- When 'Printer is off line' appears, operate the PARK softkey and wait until the print cartridge parks at the centre of travel.
- Note the position of the ADVANCE softkey.



B2.1 Old chart removal

Open the door of the recorder by lifting the latch and rotating it clockwise. If fitting a chart for the first time, or if the previous chart has already been removed, go to section B2.2.

Pull the paper guide forwards, as shown, and disengage the remaining chart from the drive sprockets. Pull the end of the chart downwards clear of the platen.*

Open the lower paper tray by rotating it forwards as shown in the figure, and remove the old chart.

Remove any residual paper dust from the paper tray.

* To free the paper, it may occasionally be necessary to release the platen, by lifting the latches as shown in figure B2.2a.

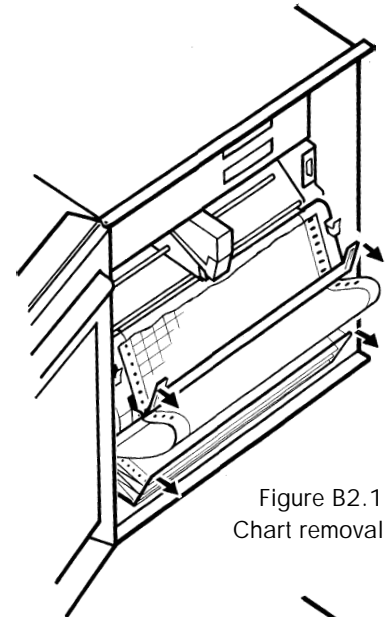

Figure B2.1
Chart removal

B2.2 Fitting a new chart

Release the platen by pushing upwards on both latches, as shown. Swing the platen forwards to reveal the upper paper tray. Remove any residual paper dust.

Check that the printhead guide bars are clean and shiny and that the drive belt and flexi cable for the printhead are in good condition. If not, carry out remedial action as described in the Service Manual.

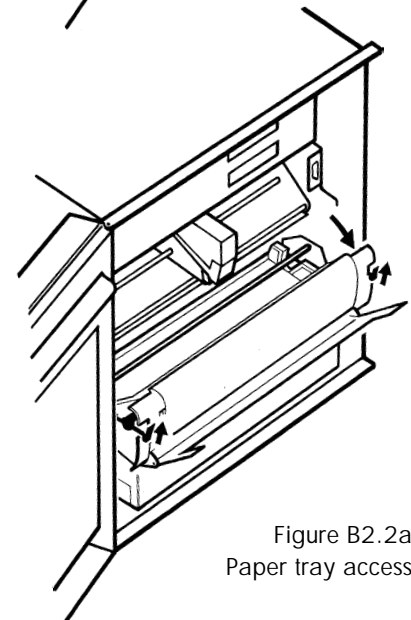

Figure B2.2a
Paper tray access

B2.2 FITTING A NEW CHART (Cont.)

Remove the new chart from its packing and fan (as shown in figure B2.2b) several times to separate the leaves, and to remove loose paper dust. Ensure that the leaves are fully separated, or the paper transport will not operate correctly.

Orient the chart such that the red end-of-chart line is at the bottom, and the circular chart holes are to the left (i.e. the elongated slots are to the right). Load the chart into the upper paper tray (passing it under the tie bar).

Unfold the top two or three leaves and pull them forwards under the tie bar (figure B2.2c)

As shown in figure B2.2d, push the platen closed **ENSURING THAT IT LATCHES CORRECTLY INTO PLACE.**

Pull the paper guide forwards and feed the end of the chart through the gap between the platen and the paper guide. Close the paper guide, ensuring that both sets of chart holes locate correctly on the drive sprockets, and that the horizontal grid lines are parallel with the chart guide.

If the chart is loaded correctly, the circular holes will be on the left, and the printed grid will be uppermost, with no red line showing.

Open the lower paper tray and introduce the first leaves of chart into it. Close the paper tray and use the ADVANCE softkey to feed extra paper through.

Ensure that the paper lies naturally (i.e. the fold direction is the same as when packed by the chart manufacturer).

FAILURE TO ENSURE THAT THE CHART FOLDS NATURALLY WILL RESULT IN THE EVENTUAL MALFUNCTIONING OF THE CHART FEED.

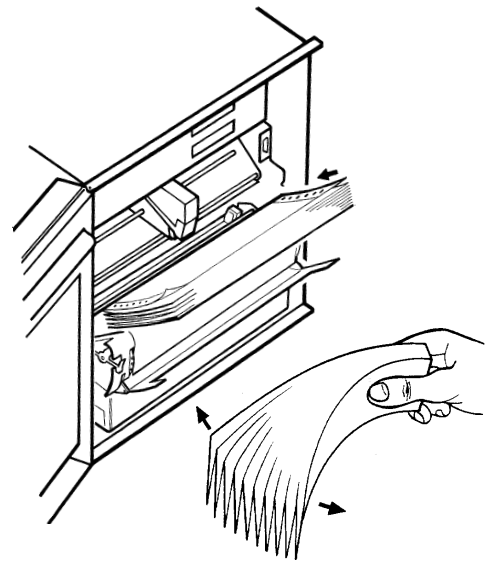

Figure B2.2b Chart loading (1)

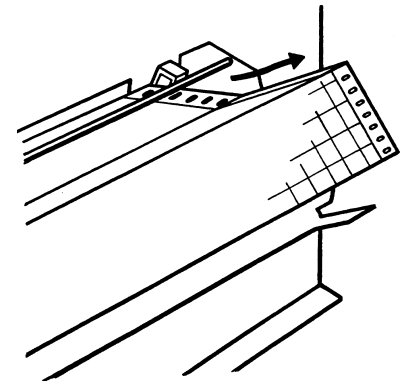

Figure B2.2c Chart loading (2)

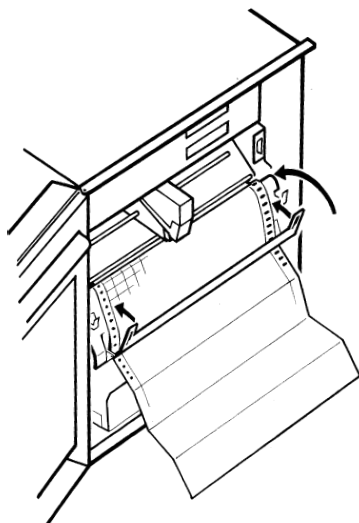

Figure B2.2d Chart loading (3)

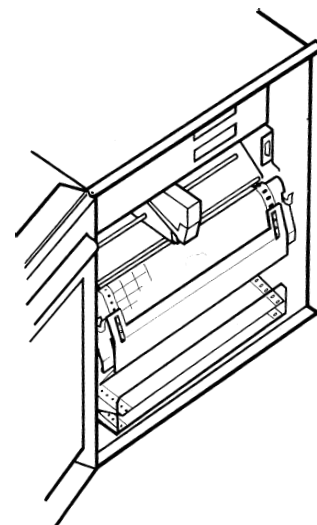

Figure B2.2e Chart loading (4)

B3 PRINT CARTRIDGE REPLACEMENT

CAUTION

BEFORE ATTEMPTING TO CHANGE THE PRINT CARTRIDGE IT IS ESSENTIAL TO ENSURE THAT:

- a. THE RECORDER IS NOT POWERED, OR
- b. THE PRINthead IS PARKED

Switch the printer off-line and park the printhead as described in section B2 above.

Pull the print cartridge forwards to remove it.

Unpack the new cartridge and push it onto the carriage (figure B3). Ensure that the unit is pushed fully home.

Note: To ensure maximum print cartridge life when the recorder is to be left unpowered for an extended period, the cartridge should be removed from the recorder and stored in a sealed container.

B3.1 Pen lift bar

The following is relevant, only if the cartridge is replaced with power applied to the recorder.

To prevent blotting whilst the recorder is switched off, the pen nibs are lifted from the chart by a small bar.

This bar is pulled out of the way (by a voltage pulse across a solenoid) when power is switched on, and held out of the way by a small 'holding' voltage.

When you remove the cartridge with the recorder powered, it is possible, inadvertently, to pull this bar forwards to the extent that the holding voltage is insufficient to pull it back in again. If this happens, the nibs of the replacement cartridge will be held off the chart by the bar, and will appear to be not working.

Should this happen, the bar can either be gently pushed back (figure B3.1), or the recorder powered off for a few seconds and then back on again.

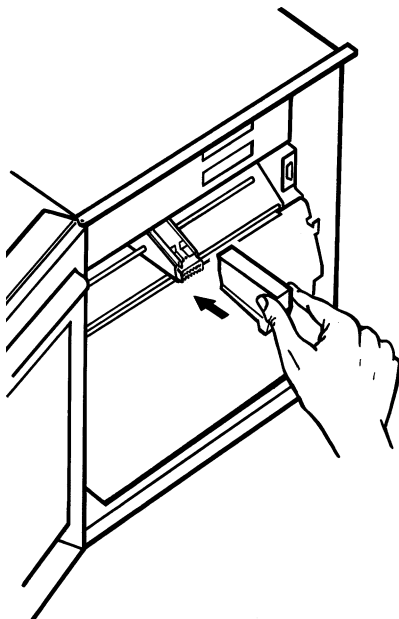

Figure B3 Printhead replacement

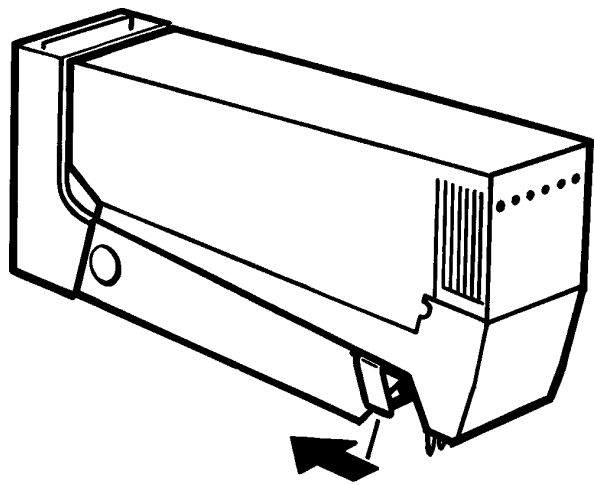

Figure B3.1 Pen lift bar

INDEX

Symbols

2-Line softkey 3 - 6

A

Access softkey 4 - 38

Access to channel address switches 4 - 14

ACK softkey 3 - 11

Adaptive recording 4 - 13

Adjust softkey 4 - 41

Advance softkey 3 - 9

Alarm

Acknowledgement 3 - 11

Actions 4 - 20

Average 4 - 23

Configuration 4 - 20 to 4 - 24

Deviation 4 - 23

Dwell 4 - 23

Enable 4 - 23

Hysteresis 4 - 23

Rate 4 - 23

Reference 4 - 23

Setpoint 4 - 23

Softkey 3 - 11, 3 - 12

Type definition

Absolute 4 - 20 to 4 - 24

Digital 4 - 22

Analogue output

Diagnostics 4 - 34

Offset 4 - 19

Range 4 - 19, A - 7

Source 4 - 19

Use as transmitter power supply 1 - 6

Archive interval 4 - 7

Autoconfiguration 4 - 38

Average

Channel 5 - 13

Group 5 - 13

Rolling 5 - 13

B

Battery pack replacement 6 - 2

Bell symbol 2 - 4

Board softkey 4 - 34

C

CALIB softkey 4 - 44 to 4 - 46

Calibration

CJ adjust 4 - 45

Input adjust 4 - 44

Pens to paper 4 - 43

Cancel key usage 2 - 3

Changing the password 4 - 10

Channel

Addressing 4 - 14

CHANNEL (Cont.)

Alarm

Bell symbol 2 - 4

Configuration 2 - 10, 4 - 20 to 4 - 24

Average (maths function) 5 - 13

CJC type entry 4 - 16

Colours 4 - 26

Configuration 4 - 14 to 4 - 27

Damping 4 - 17

Decimal place 4 - 17

Descriptor entry 2 - 12, 4 - 27

Ident 4 - 27

Input break response 4 - 17

Input type 4 - 16

Line thickening 4 - 26

Linearisation function entry 4 - 17

Open/Closed legends entry 4 - 16

Range

Input channels 2 - 8, 4 - 16

Output channels 4 - 18

Scaling 4 - 17

Shunt value entry 4 - 16

Softkey 3 - 12, 4 - 16, 4 - 38

Tag entry 2 - 12, 4 - 27

Trace configuration 2 - 12, 4 - 26

Units 4 - 17

Units entry 4 - 16

Zone configuration 2 - 11, 4 - 25

Character sets 2 - 4

Chart

Adjustment 4 - 43

Fitting 1 - 10 to 1 - 11, B - 4 to B - 5

Illumination tube replacement 6 - 2

Off-line (P) symbol 2 - 4

On-off 1 - 10

ON/OFF softkey 3 - 9

Printing configuration on 4 - 46

Scale 4 - 25

Softkey 3 - 9, 4 - 13, 4 - 38

Span 4 - 25

Speed

Configuration 2 - 8, 4 - 13

Operator selection 3 - 9

Circuit board addresses 4 - 10

CJ temp softkey 4 - 34

Clock softkey 3 - 18, 4 - 9

Comms softkey 4 - 34

Communications See HA246958

CONFIG softkey 2 - 7 to 2 - 8, 3 - 19

Configuration

Access to 2 - 7 to 2 - 8, 3 - 19

Alarm 4 - 14

Alarm messages on/off 4 - 9

Channel 4 - 14 to 4 - 27

Chart 4 - 12 to 4 - 13

Chart zone 4 - 25

Circuit board locations 4 - 10

Clock 4 - 9

Copying 2 - 16 to 2 - 18, 4 - 32

CONFIGURATION (Cont.)

Counters	5 - 6 to 5 - 7
Custom linearisation table	4 - 11
Custom messages	4 - 9
Custom scales	4 - 9
Cycle time	4 - 11
Display language	4 - 10
Group	2 - 13, 4 - 28
Instrument	4 - 8 to 4 - 11
Internal events	4 - 29 to 4 - 30
Log	
Content / destination	4 - 31
Interval	4 - 13
Maths pack	5 - 10 to 5 - 11
Operator Keys	4 - 10
Password	4 - 10
Print mode	4 - 13
Printout	4 - 46
Remote cold junction	4 - 11
Timers	5 - 8 to 5 - 10
Totalisers	5 - 4 to 5 - 5
Transfer	4 - 33
Zone	4 - 25
Configuration disabled by comms message	7 - 3
Content softkey (Group)	4 - 28
Copying channel/alarm config.	2 - 16 to 2 - 18, 4 - 32
COSHH data	7 - 4 to 7 - 7
Counter softkey	3 - 14, 4 - 38
Counters option	5 - 6 to 5 - 7
Cycle softkey	4 - 11

D

Date	
Format	4 - 9
Setting	4 - 9
Decimal point position	4 - 19
Default softkey	4 - 37
Descriptor entry	
Channel	2 - 12, 4 - 27
Counters	5 - 6
Event	4 - 30
Group	4 - 28
Timers	5 - 8
Totalisers	5 - 4
Diagnostics	4 - 34
DIR softkey (M Card)	3 - 20
Display	
Modes	
Indicator	3 - 8
Numeric	3 - 7
PV Select	3 - 8
Softkey	3 - 6, 4 - 37
Display/Keyboard	2 - 3
Dwell	4 - 20

E

Edit 1(2) softkey	3 - 16
Embedded sequences	3 - 16 to 3 - 17
Enter key usage	2 - 3
Event configuration	4 - 30

F

Fail-safe setting	4 - 19
Failure to adjust message	7 - 2
Failure to calibrate message	7 - 2
Failure to remove... message	7 - 2
Fast Off softkey	3 - 9
Format softkey	3 - 20, 4 - 13, 4 - 28
Fvalue equation	5 - 15

G

Group	
Average (Maths function)	5 - 13
Configuration	2 - 13, 4 - 28
Contents	4 - 28
Format	4 - 28
Selection for display	2 - 14 to 2 - 16
Softkey	4 - 38
Title	4 - 28
Group softkey	4 - 28

H

Hardkey usage	2 - 3
High/low select maths functions	5 - 20
Hold softkey	3 - 6
Home key usage	2 - 3
Host Comms.	<i>See HA246958</i>
Hysteresis	4 - 20

I

I symbol	2 - 4
Ident softkey	3 - 12, 4 - 27
Input adjust	4 - 41 to 4 - 42
Input type configuration	2 - 8, 4 - 16
Installation	
Chart	1 - 10, B - 4
Electrical	1 - 3 to 1 - 6, 1 - 6
Mechanical	1 - 3
Software options	5 - 3
Instrument configuration	4 - 8 to 4 - 11
Interpolation	4 - 13
INTRVL softkey	3 - 20
Invalid configuration message	7 - 3
Invalid index message	7 - 3

J

Job source search	3 - 18
JOB SRC softkey	3 - 18
Jobs overview	4 - 6 to 4 - 7
Jobs softkey	4 - 24

K

Keys softkey	3 - 15, 4 - 10
--------------------	----------------

L

Latched alarms	4 - 20
LIN TAB softkey	4 - 11
Line supply wiring	1 - 3
Line thickening	4 - 26
Listen softkey (Comms)	4 - 37

L (Cont.)

Log	
Configuration	4 - 31
Destination (Chart or Memory card)	4 - 31
Initiation	
By job	4 - 7
Manual	3 - 17, 4 - 7
Interval	4 - 7
Configuration	4 - 13
Operator selection	3 - 10
Softkey	4 - 38
To chart	4 - 7
To memory card	4 - 7
LOG INT softkey	3 - 10, 4 - 13
Loopback softkey	4 - 37

M

M CARD softkey	3 - 20, 4 - 37
Mass flow calculation	
Linear	5 - 16
Square root	5 - 18
Maths	
Equations	5 - 13 to 5 - 20
Functions	5 - 12
Maths pack option	5 - 10 to 5 - 20
Maths softkey	3 - 14, 4 - 38
Mechanical Installation	1 - 3
Memory card.	<i>See HA247361</i>
Message	
Editing	4 - 9
Printing	3 - 16, 4 - 9
Mode softkey	
Display mode	3 - 6
Print mode	3 - 10, 4 - 13

N

Nernst equation	5 - 19
Networking	<i>See HA247733</i>
Ni-cad battery COSHH data	7 - 6 to 7 - 7

O

Off softkey	3 - 9
Offline softkey	3 - 20
On-error	4 - 19
On/off softkey (Chart / Printer)	3 - 9
On/Off switch	2 - 2
Operator	
Access permissions	4 - 38
Alarm page	3 - 11
Channel page	3 - 12 to 3 - 13
Chart control page	3 - 9 to 3 - 10
Interface	2 - 3
Log interval selection	3 - 10
Messages	3 - 16
Print mode selection	3 - 10
Process page	3 - 14
Softkeys	
Jobs	4 - 30
Legends	4 - 10

Operator (Cont.)

Top level menu	
Page 1	3 - 6
Page 2	3 - 14 to 3 - 17
Page 3	3 - 18 to 3 - 19
Page 4	3 - 20
Option Installation	5 - 3
Option key location	5 - 3
Output	
Adjustment	4 - 43 to 4 - 46
Type	4 - 19
Output (Diagnostics)	4 - 34
Oxygen potential measurement	5 - 19

P

P symbol	2 - 4
Park softkey	3 - 9
Password	
Configuration	4 - 10
Entry	2 - 8
Pens softkey	4 - 34
PERIOD+ softkey	3 - 13
Permissions	4 - 38
Preset counter	5 - 6
Print 1(2) softkey	3 - 16
Print cartridge replacement	B - 6
Print mode	
Definition of	4 - 13
Operator selection of	3 - 10
Printer must be on/off line message	7 - 3
Printer off-line symbol	2 - 4
Printhead ink COSHH data	7 - 4 to 7 - 5
Printing	
Configuration on the chart	4 - 46
Operator messages	3 - 16
Scales	3 - 10
Time and date in messages	3 - 17
Process softkey	3 - 14

Q

Quick scale print	3 - 10
-------------------------	--------

R

Range softkey	4 - 16
Rate of change maths function	5 - 13
Recorder	
Labelling symbols	i - 3
Messages	7 - 2
On/off	2 - 2
Relative Humidity calculation	5 - 14
Relays softkey	4 - 34
REM CJ softkey	4 - 11
Remote CJ configuration	4 - 11
Removal of writing system	5 - 3
Replacing	
Battery pack	6 - 2
Chart illumination tube	6 - 2

R (Cont.)

Restore softkey	
Configuration transfer	4 - 33
Memory card	3 - 20
Rolling average maths function	5 - 13

S

Safety notes	i - 3
Save softkey	
Configuration transfer	4 - 33
Memory card	3 - 20
SBC softkey	4 - 34
Scale format	4 - 13
Scales softkey	3 - 10
Scroll softkey	3 - 6
Send softkey	3 - 17
Serial communications.	See HA246958
SET PT softkey	3 - 13, 4 - 23
Setting	
Alarm parameters	2 - 10, 4 - 23
Channel	
Input type	2 - 8
Name (descriptor/tag)	2 - 12, 4 - 27
Range	2 - 8, 4 - 17
Chart speed	2 - 8, 4 - 13
Chart zone	2 - 11, 4 - 25
Display format	2 - 9, 4 - 28
Linearisation type	2 - 9, 4 - 17
New password	4 - 10
Pen zero and span	4 - 43
Trace colours	2 - 12, 4 - 26
Trace on/off	2 - 12, 4 - 26
Settings softkey	
Configuration transfer	4 - 33
Signal wiring	1 - 6
Source (analogue output channels)	4 - 19
Specification	
16-channel dc input board	A - 6
8-channel universal input board	A - 4
Analogue output board	A - 7
Relay output board	A - 7
Speed softkey	3 - 9, 4 - 13
Static electricity precautions	i - 4
Status indicators	2 - 4
Status softkey	3 - 20
Stopwatch maths function	5 - 20
Supply voltage	
Connection	1 - 3
Fuse specification	1 - 5
Selection	1 - 3
Switch maths function	5 - 20

S (Cont.)

Switching	
Chart on/off	1 - 10
Recorder on/off	2 - 2
Symbols (Recorder labelling)	i - 3
SYS ERR softkey	3 - 19
System alarm (I) symbol	2 - 4

T

Tag entry	2 - 12, 4 - 27
Talk softkey	4 - 37
Test softkey	4 - 37
Text editing	2 - 4
Text only print mode	4 - 13
Text priority print mode	4 - 13
TEXT softkey	3 - 16
Time and date inclusion in messages	3 - 16
Time and Date setting	4 - 9
Time stamp maths function	5 - 20
Timer softkey	3 - 15, 4 - 38, 5 - 8
Timers option	5 - 8 to 5 - 10
Title softkey	4 - 28
Top level operator menu pages	3 - 5
Totaliser option	5 - 4 to 5 - 5
TOTAL'R softkey	3 - 14, 4 - 38, 5 - 4
Trace priority print mode	4 - 13
Trace softkey	4 - 26
Traces softkey	4 - 13
Transfer configuration	4 - 33
Transfer softkey	4 - 33
Transmitter Power Supply	
Analogue o/p channel	1 - 6
Trigger alarms	4 - 20

U

Unlatched alarms description	4 - 20
User linearisation table entry	4 - 11

V

Version softkey	4 - 37
-----------------------	--------

W

Wiring	
Configuration transfer	1 - 6
Mains	1 - 3
Signal	1 - 6
Writing system removal	5 - 3

Z

Zirconia probe maths functions	5 - 19
Zone softkey	4 - 25

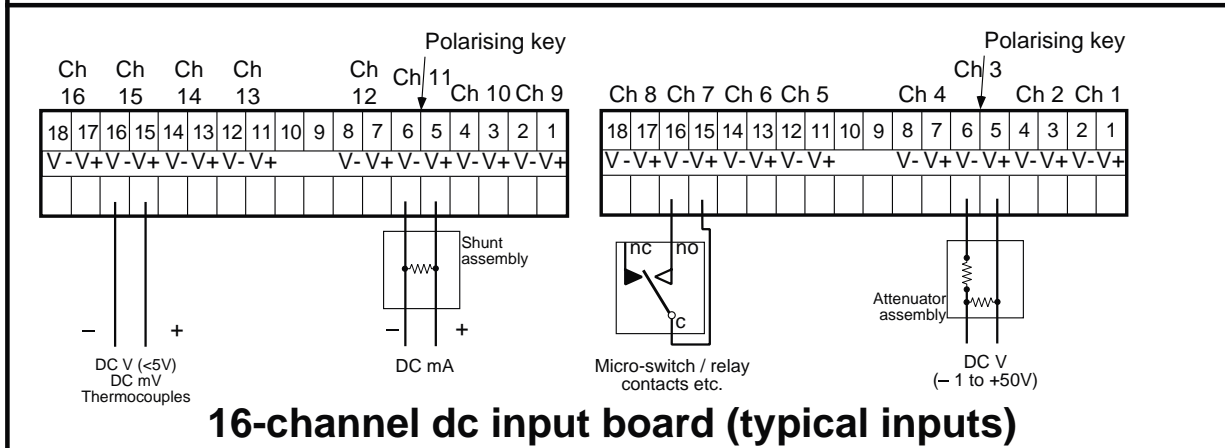
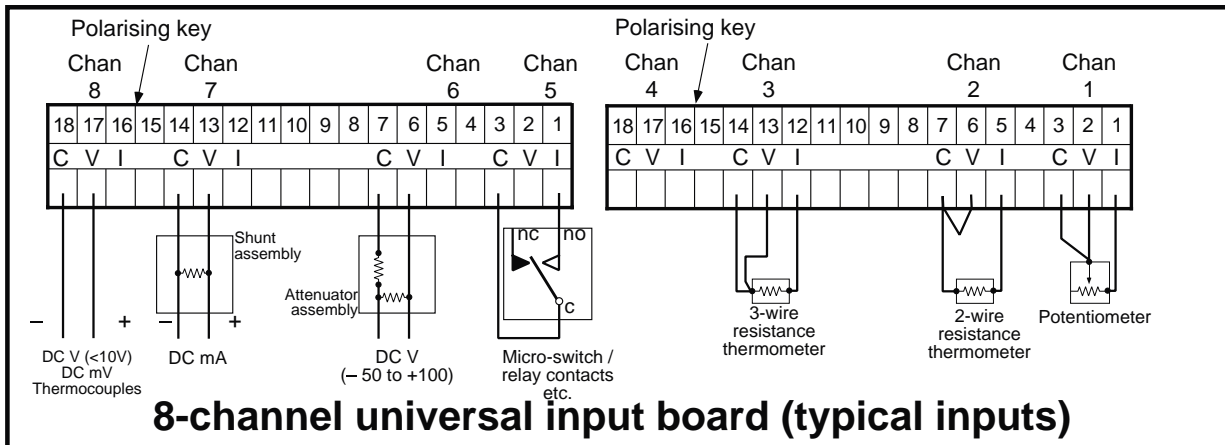

Shunt part n s: 100 = LA246779UK10; 250 = LA246779UK25. Attenuator part n = LA244180U100

