

EUROTHERM

EUROCUBE 424-426 THYRISTOR UNIT- SOLID STATE CONTACTOR PHASE ANGLE, FAST CYCLE AND SLOW CYCLE

Maintenance Manual

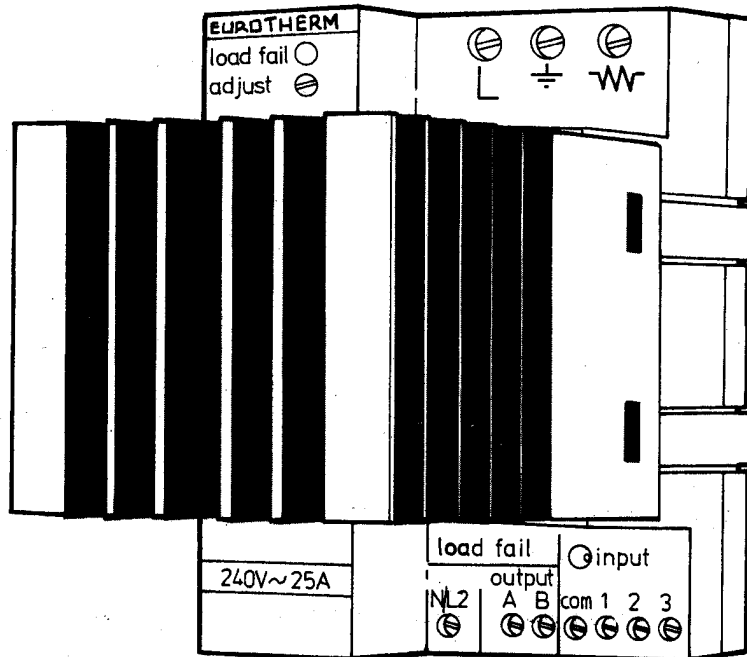

425 Solid state Contactor

CONTENTS

Section	Title	Page
1.0	GENERAL DESCRIPTION	1
2.0	TECHNICAL SPECIFICATION	2
3.0	ORDERING INFORMATION/PRODUCT IDENTIFICATION CODE	3
4.0	WIRING	4
4.1	Supply connection	4
4.2	Control Signal Input	5
4.3	Partial Loading Failure Detection - Option 37	6
4.4	Current Limit - Option 55	6
4.5	Fusing	6
5.0	TYPICAL WIRING SCHEMES	8
6.0	CIRCUIT DESCRIPTION	9
6.1	Mother Board	9
6.1.1	Solid State Contactor (On/Off Thyristor)	9
6.1.2	Phase Angle, Fast Cycle and Slow Cycle Version	10
6.2	Partial Load Failure Detection Board	11
6.3	Feedback and Current Limit Board	12
7.0	DISMANTLING INSTRUCTIONS	24
8.0	SUGGESTED SPARES	24
9.0	SALES AND SERVICE LIST	27

Every effort has been made to ensure the accuracy of the information in this manual. However, in order to maintain our technological lead, we are continuously improving our products which could, without notice, result in amendments, errors and omissions. We cannot accept responsibility for damage, injury, loss or expenses resulting therein.

LIST OF ILLUSTRATIONS

Figure	Title	Page
1	Logic Input - Solid State Contactor Version	4
2	PA, FC, SC Version	4
3	AC Input - Solid State Contactor	8
4	220/240V System - Phase Angle, Fast Cycle or Slow Cycle	8
5	Eurocube (SSC) PLF Board - Layout	13
6	Eurocube (SSC) 425/426 Mother Board - Circuit Diagram	14
7	Eurocube (SSC) 425/426 Mother Board - Layout	15
8	Eurocube (PA, FC, SC) Mother Board - Circuit Diagram issue 3	16
9	Eurocube (PA, FC, SC) Mother Board - Layout issue 2	17
10	Voltage Feedback & Current Limit Board - Circuit Diagram (Revised)	20
11	Voltage Feedback & Current Limit Board - Layout (Revised)	21
12	Eurocube 424 (SSC) Motherboard - Circuit Diagram	22
13	Eurocube 424 (SSC) Motherboard - Layout	23
14	Eurocube Exploded View	25

1.0 GENERAL DESCRIPTION

The Eurocube thyristor unit can be supplied in three basic forms.

These are:

- the solid-state contactor, with a logic input requirement and on/off firing mode - 424, 425, 426;
- the thyristor unit, with analogue input requirements and either phase-angle, fast cycle or slow cycle firing mode - 425, 426;
- the solid-state contactor, with an ac input requirement and on/off firing mode - 424.

The Eurocube solid state contactor (SSC) has been designed as a low cost replacement unit for mechanical contactors when switching single phase resistive loads up to 40 Amps. The 424/425/426 SSCs are capable of line to neutral (110 or 240V) operation. The 425/426 can operate on line to line (440V). The logic input (or ac input - 424) is isolated and interference is kept to a minimum by automatic zero-crossing firing of the thyristors. There is an optional load monitoring facility (partial load failure detection) with relay contact output.

The Eurocube 425/426 phase-angle, fast cycle and slow cycle versions are replacements for saturable reactors and are designed for loads taking up to 40 Amps. Line to neutral (110 or 240V) and line to line (440V) operation is possible. The fast cycle and slow cycle types have automatic zero-crossing firing for minimal electrical interference. The phase-angle version has an optional current limiting facility.

Four current ranges are available. These are 12A (424), 15A, 25A, and 40A.

The Eurocube features a compact mechanical design which mounts on a pressed-steel baseplate. This can be fitted to a DIN rail (available from Eurotherm) with clips, or screwed to a bulkhead.

Electrical connections are made to terminals at the top and bottom of the unit. Fusing can either be situated remotely on the main fuse panel using a standard fuseholder or by a Eurotherm type 408 or 409 combined fuse and fuse holder at the unit. The heatsink is isolated and the electronics are shrouded for safety of operation.

The compact physical design of the Eurocube gives the industrial equipment designer considerable flexibility where space is at a premium e.g. when used in small laboratory furnaces, environmental chambers, ovens, kilns, plastic injection moulding and extrusion machinery, textiles machinery, etc.

2.0 TECHNICAL SPECIFICATION

General	Supply voltage	+ 10% – 15% of nominal
	Off-state current	<30mA
	Operating temperature range	0°C to 50°C full operation
	Storage temperature range	- 10°C to + 70°C
	Driver Supply (Analogue only)	200 – 260V
Terminals	Light current	Screw 0.5-2.5mm ² wire size, single or multi-strand.
	High current	Screw with clamp. Cable size: 15-40A 6-16mm ²
Logic Input (Isolated from load circuitry)	Low voltage — 10V max	Logic signal limits:— ON>5V dc; OFF<1V dc — 4mA min.
	High voltage — 25V max	ON>9V dc; OFF<1V dc — 4mA min. 25V dc max.
	Current — 20mA max	ON>4mA; OFF<2mA
Analogue Input (Isolated from load circuitry)	dc voltage	0 – 5V 1 – 5V 0 – 10V
	dc current	0 – 5mA 0 – 10mA 0 – 20mA 4 – 20mA
	Manual	Provision for external 5k ohm potentiometer
	AC Input	24V ac 48V ac 100-240V ac
Output	Current and voltages	Up to 40A, 240V or 440V (SSC) or up to 40A 240V (PA, FC, SC)
	Firing Mode	Solid-state contactor Phase angle Fast cycle Slow cycle
Partial load failure option	General	Compares load current: load voltage to detect load resistance increases.
	Minimum operating current (all units)	2A dc
	Discrimination	better than 20% (1 in 5)
	Adjustment	Front panel accessible potentiometer.
	Indication	Red LED on front panel
Current limit	Alarm output	Relay. Contact rating 0.25A 250V ac or 30V dc.
	Phase angle only	Front panel accessible potentiometer
Weight and Dimensions	Dimensions (mm)	424 125 x 96 x 94 425 125 x 96 x 130 426 125 x 116 x 155
	Weight	424 600gm 425 800gm 426 1.1kg

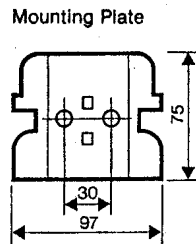
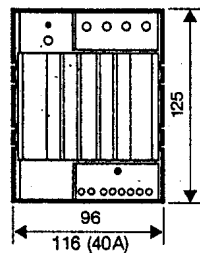
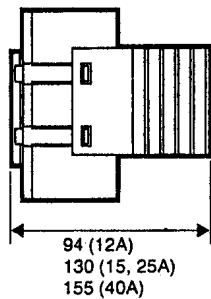

Asymmetrical DIN Rail

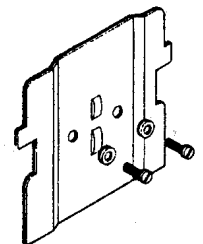
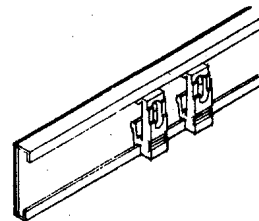

DIN rail BA 016165

All dimensions in millimetres

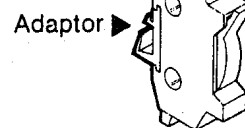
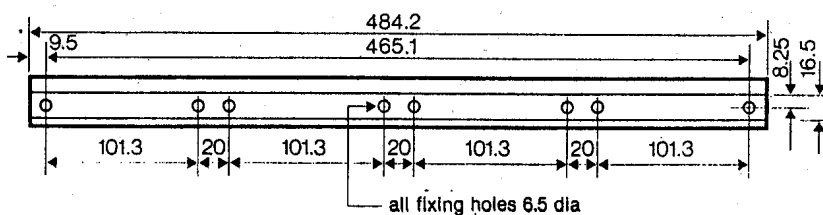

3.0 ORDERING INFORMATION/PRODUCT IDENTIFICATION CODE

You are welcome to order by description or from the code below which is a useful checklist.

Output Current and Voltages

	RMS Voltage Rating Code	Output Current Code	Basic Product Code
12A 100-240V ●	40	146	424
15A 110V	10	081	425
15A 240V	13	081	425
15A 440V ●	28	081	425
25A 110V	10	082	425
25A 240V	13	082	425
25A 440V ●	28	082	425
40A 110V	10	083	426
40A 240V	13	083	426

● Solid State Contactor only

Driver Supply Voltage (PA, FC and SC only)

Driver Supply Voltage	Code
230V +10% -15%	36
115V +10% -15%	11
Solid State Contactor (SSC)	00

Input

Input	Code
Logic 5-10V dc, 10-25V dc, 4-20mA (SSC)	137
0-5V dc	008
1-5V dc	068
0-10V dc	060
0-5mA dc (PA, FC and SC only)	069
0-10mA dc	071
0-20mA dc	072
4-20mA dc	073
AC input, 24V, 48V, 100-240V (424 only)	155

Firing Mode

Firing Mode	Code
On/off Thyristor (SSC)	161
Fast Cycle (FC)	001
Slow Cycle (SC)	050
Phase Angle (PA)	002

Options

Options	Code
Partial load fail detection (contacts open in alarm) *	37
(contacts closed in alarm) *	83
Current limit (PA only)	55
Symmetrical and asymmetrical DIN rail mounting kit	33

* 425/426 logic input only

A fuse-holder and fuse is available separately:

A suitable high speed fuse must be fitted with each unit.

Recommended fuses and fuseholders are detailed below:

Fuseholder and Fuse

Fuse Only

Order 409-081 for 12A/15A units 409-082 for 25A units 408-083 for 40A units	Order CH 260024 for 12A/15A units CH 260034 for 25A units CH 330054 for 40A units
---	---

Note:

Baseplate is suitable for bulkhead mounting or DIN rail mounting. Any asymmetrical DIN rail (DIN 46277 Part 1) and mounting brackets may be ordered as separate items: DIN rail BA 016165 Brackets BD 018267 (two required per Eurocube)

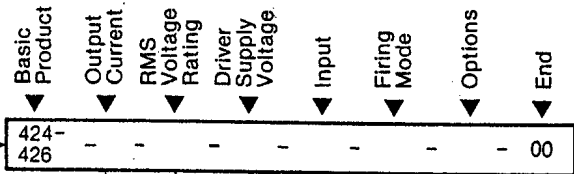

4.0 WIRING

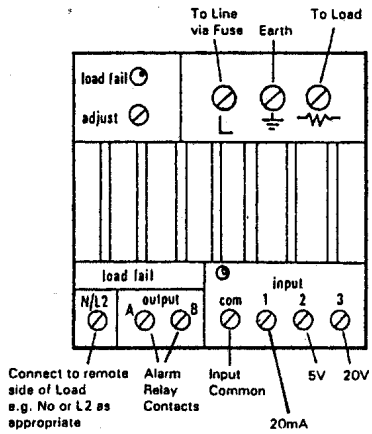

Figure 1 Logic Input-Solid State Contactor Version

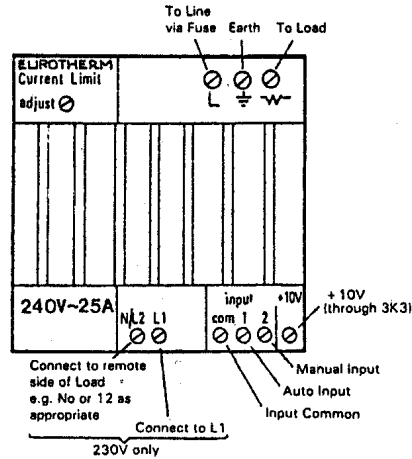

Figure 2 PA, FC, SC Version

Note: For 110V driver supply terminal L1 is moved to the right.

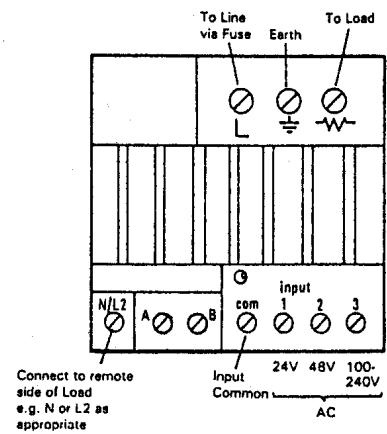

Figure 3 AC Input - Solid State Contactor

4.1 Supply Connection

These connections carry the load current into and out of the thyristor unit. Correct polarity must be observed, as malfunction of the firing circuits will occur if the connections are crossed. Terminal 'L' must be connected to the line supply. Terminal '-W-W-' is connected to the load. The other side of the load is connected either to the neutral or another line dependent on whether the load is fed between line and neutral or line and line.

The Eurocube should be earthed via the terminal provided. This will earth the heatsink.

ALL CONNECTIONS MUST BE TIGHTENED FIRMLY

The supply voltage must be within well defined limits which are:-

110V	94-121 volts rms
240V	198-264 volts rms
440V	342-478 volts rms

If the PLF option (37) or (83) is fitted, the supply across the load must be monitored. Therefore, if the load is fed between line and neutral, the L terminal will be connected to line and the N/L2 terminal will be connected to neutral. If the load is fed between two lines, L1 and L2, then terminal L is connected to L1 and terminal N/L2 would be connected to L2.

Driver supply connections are made to N/L2 and L1 as shown in the diagram above.

4.2 Control Signal Input

4.2.1 Solid State Contactor (On/Off Thyristor)

The Eurocube 424, 425 and 426 SSC operate with a dc logic signal input (normally from a temperature controller). The logic input is isolated by an opto-coupler for safety. Three types of signal are provided for, as shown below. The logic drive from the temperature controller should be connected to terminals Com, 1, 2 and 3 depending on the signal from the controller.

Alternatively, the 424 can be supplied to accept an ac input signal to one of the three input terminals, with respect to the common terminal.

DC Logic Input

CONTROLLER SIGNAL (MAX)	LOW TERMINAL	HIGH TERMINAL
Current: 20mA	Com	1
Low Voltage: 10V	Com	2
High Voltage: 25V	Com	3

The correct polarity of this signal must be observed, ie terminals 1, 2 and 3 are positive and Com terminal is negative.

AC Input

INPUT SIGNAL (NOMINAL)	MIN.	MAX.	INPUT TERMINAL
24V ac	20V	30V	1
48V ac	30V	55V	2
100 to 240V ac	90V	264V	3

The 'Input' LED indicator will light whenever the input signal is applied.

4.2.2 Phase Angle, Fast Cycle and Slow Cycle Version

The Eurocube 425 and 426 Phase Angle, Fast Cycle and Slow Cycle thyristor unit requires an analogue input signal. The thyristor drive signal is isolated from the power circuit for safety by a transformer. Three types of voltage signal and four types of current signal are possible, depending on the option chosen. These are listed below.

A Manual input, terminal 2, is also supplied, enabling an external 5K ohm potentiometer to be used. This would be connected between the reference supply + 10V terminal 3 and 0V terminal Com, with the potentiometer wiper on terminal 2.

Controller Signal	Code	Controller Signal	Code
0-5V	008	0-10mA	071
1-5V	068	0-20mA	072
0-10V	060	4-20mA	073
0-5mA	069	Input between Com and terminal 1 (positive)	

The 'Input' LED indicator will light whenever the firing signal is operating.

4.3 Partial Load Failure Detection - Option 37 or 83

If this option is fitted to the stack, then a relay output is available from the terminal marked Load Fail Output A and B. The contacts are open in the alarm state or off (Fail Safe) for option 37, and closed in the alarm state for option 83.

Contact rating is 0.25A at 250V ac or 30V dc maximum. Release of this relay coincides with the illumination of the Partial Load Failure indicator LED mounted on the front panel. When the load-resistance increases or goes open-circuit, the indicator will be illuminated and the relay output will switch.

The setting of the PLF function is as follows. This feature compares the instantaneous voltage and current signals to identify a load impedance change. Since the load current may not equal the thyristor unit maximum current, there must be a setting-up procedure for each particular load. With the correct complete load connected to the thyristor unit, the thyristor unit wired correctly and with current being delivered to the load (the load current can be any value other than zero) turn the Partial Load Failure adjustment control fully anti-clockwise and note that the indicator is not illuminated. Now turn the control slowly in a clockwise direction until the indicator illuminates. Then turn the control in anti-clockwise direction until the indicator is just extinguished. The Partial Load Failure control is now set in the correct position to give maximum sensitivity.

4.4 Current Limit - Option 55

If this option is fitted to the thyristor unit (Phase Angle version only) a front panel control is fitted. This feature operates by monitoring the current delivered to the load by use of a current transformer.

The setting procedure is as follows. With the load connected, turn the current limit potentiometer to minimum position (fully anti-clockwise). Set the input signal to zero and switch on the supplies. The rms output voltage should be minimal. Increase the input signal to approximately 100%. The output voltage should remain below 15% of the supply voltage. Gradually increase the current limit smoothly. Leave the current limit set at the maximum safe current for the load.

4.5 Fusing

No fuse is supplied with the Eurocube but one is available separately in fuseholder (Type 408 or 409). Alternatively, the fuse may be accommodated remotely on the main fuse panel. In all cases the fuse must be a fast-acting semi-conductor protection fuse, rated to protect the thyristor stack at its maximum output. If the 'Input' LED indicator is lit and no power is being applied to the load, switch

off and check the fuse and connections.

WARNING: THE HEATSINK MAY BE HOT. TAKE GREAT CARE.

The type 408 or 409 fuseholder may be secured to a bulkhead or panel using 4mm screws, or clipped to a DIN rail.

Note: The current and voltage figures on the fuseholder are the maximum rating for the fuseholder and not the rating of the fuse which is fitted.

Figure 3 Single Phase System - Solid State Contactor

(For 380/440V stack, wire terminal N/L2 and Load to Line 2).

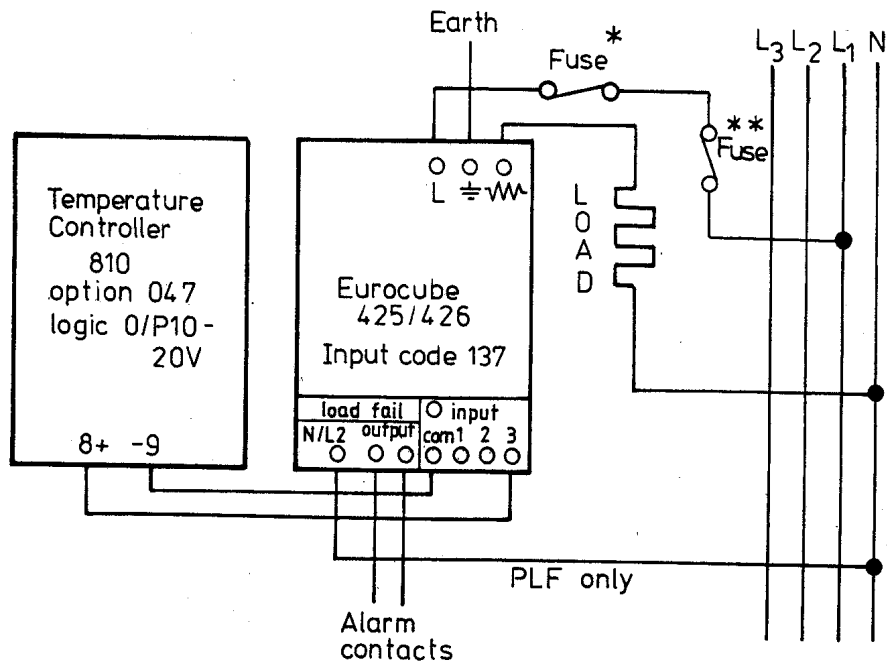
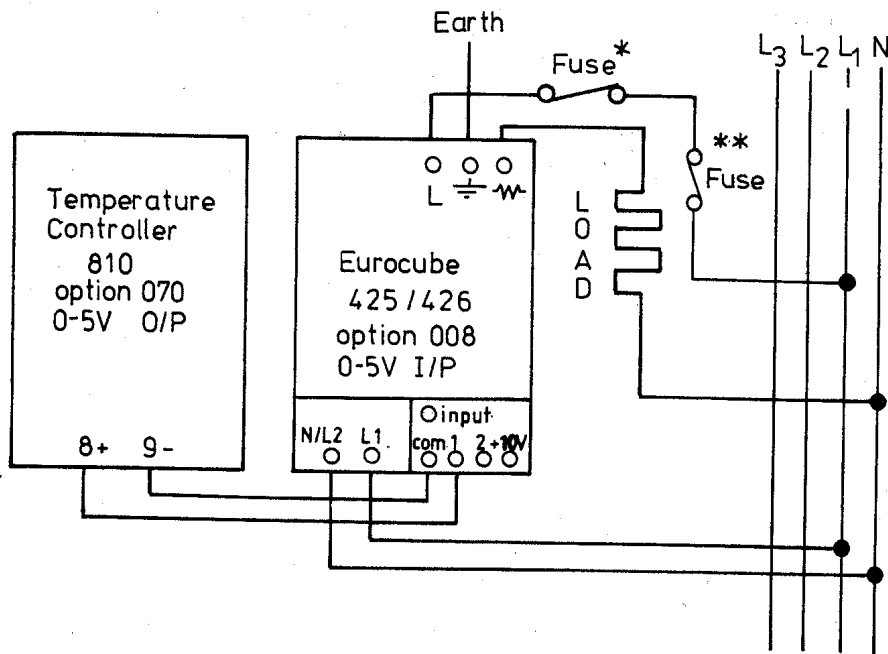

Figure 4 220/240V System - Phase Angle, Fast Cycle or Slow Cycle.



- * High-speed semi-conductor fuse (type 408, 409)
- ** HRC fuse or circuit breaker for circuit protection

6.0 CIRCUIT DESCRIPTION

6.1 Mother Board

6.1.1 Solid State Contactor (On/Off Thyristor)

Refer to Figures 6 and 12.

D3, D4, D5 and D6 form a full wave-rectifier bridge to provide a supply for the triggering circuit.

The logic input to the opto-isolator will be to terminal 1 for 4-20mA, terminal 2 for 1-5V and terminal 3 for 1-9V. Diode D1 protects against reverse polarity inputs and LED Input indicator lamp will light whenever the input signal is present. Com terminal is low or zero volts.

The ac input (424) will be to terminal 1 for 24V ac, terminal 2 for 48V ac and terminal 3 for 100 to 240V ac. Bridge rectifier BR1 rectifies the signal and C17 smooths it. Zener diode Z1 limits the bridge output voltage to 13V dc. LED1 Input indicator lamp will light whenever the input signal is present. Com terminal is the input low or ac return terminal.

Two versions of the main circuit are used, one for 110/240V nominal and the other for 440V nominal output. For 240V, thyristor TH1 is removed and LK4 is fitted. R11, R12, R13, C4, C5, T2 are fitted, but have no function without TH1. For normal thyristor operation, LK1 and R15 are fitted.

At the start of each half-cycle of the supply, all thyristors and transistors are non conducting (off). If the logic input is not energised, then the photo transistor in the opto-isolator ISO1 is also off. As the supply voltage moves away from zero the rectifier bridge output follows it since the power thyristors are off and the load allows the full supply voltage to appear across the thyristors. Above about 30V the current through R6 and Z1 will cause T1 to saturate holding TH2 off.

When the logic input energises the opto-isolator, the photo-transistor will prevent T1 turning on. Eventually R7, R8, R9 and R10 will pass enough current to fire thyristors TH1 and TH2. This puts a short circuit across the rectifier bridge output and fires the main thyristor which is forward biased. This action is repeated at the start of each half-cycle and causes full load current to flow. T2 is connected across the gate/cathode of TH1 and is biased to produce a voltage dividing action and share the voltage between the thyristors. C4 and C5 ensure the dividing action is accurate even in the presence of transients occurring on the supply.

If the input opto-isolator has been energised well into a half cycle this would cause the power thyristor to fire and give a large sudden change in load current. This can generate radio interference and give poor power factor. Switch-on must therefore only be allowed to occur close to the zero-crossing of the supply voltage. R6 and Z1 will turn on T1 when the bridge rectifier output reaches about 30 volts, unless the input transistor has been activated, in which case the bias current would flow that way.

6.1.2. Phase-Angle, Fast Cycle and Slow Cycle Version.

Refer to Figure 8.

a) Power Supplies

The control ac supply is applied to pins 8 and 7 or 6. Pin 7 is always 240V input, while pin 6 is 120V. The transformer TX1 secondary is centre-tapped at a nominal 15V ac. The output is full-wave rectified by diodes D4 to D7 and smoothed to provide the dc supplies for the pulse triggering transformer and the +10V and -10V. The +10V is generated by R15, Z1, and the -10V by D8, R13, R16, Z2.

b) Mains Synchronizing

The ac mains required for synchronizing the firing is derived from the secondary of the mains power supply transformer. The signal is filtered to prevent line disturbances from affecting the ramps. IC1a produces a synchronizing pulse whose positive front edge determines the zero crossover synchronizing sent to IC1d through C3, R41, D9, R18.

c) Input Circuit

Two inputs are available.

"Auto" - can be either a voltage input (0-5V, 0-10V, 1-5V) or a current input (0-5mA, 0-10mA, 0-20mA, 4-20mA) converted to a 0-5V signal.

Input range dependent resistors are R2, R5, R42. Auto input is connected to pin 3 (+) and pin 4 (zero volts).

"Manual" - is a voltage-only input, either 0-5V or 1-5V depending on auto input range.

d) Control Circuit

The input signal is compared by IC1b to the feedback signal from the daughter board. The resultant is used by IC1c to generate the firing waveform (phase-angle demand signal)

e) Firing Modes

The thyristor unit can fire in one of the following modes.

- phase-angle (with current-limit option)
- fast cycle
- slow cycle

See Firing Mode Dependent Components chart.

Phase-Angle Mode.

The ramp for controlling the phase-angle firing is generated by IC1d, pin 14 zero-synchronised from IC1a. The ramp is compared to the phase-angle demand signal (IC1b, pin 7) and provides a square wave firing signal, allowing firing from 10° to 180°.

Fast/Slow Cycle Mode

Zero-voltage synchronizing pulses, each 20ms wide are generated by IC1d, C9, R26, for the entire period of firing. IC1c is working as a hysteretic switch. When IC1c output is down at -10V, the thyristors are off, there is no feedback signal, and IC1b integrator output is rising (if there is an input signal) until pin 7 reaches the hysteretic switch high level. IC1c switch-on (to +10V) is synchronized to zero-crossover voltage by zero synchronizing pulses through IC1d, C9, R26, and allows thyristor firing. The feedback circuit then provides a current signal to integrator IC1b, making the output decrease. When the low switching level of the hysteretic switch IC1c is reached, it switches off (from +10V to -10V) stopping the thyristor firing signal. The on/off period is controlled by capacitor C2.

The square-wave firing signals (IC1c pin 8) start the pulse oscillator T2 and T3, which will trigger the thyristors. The high frequency pulse oscillator ensures that load "pick-up" problems do not occur with highly inductive loads.

f) Mains Fail

Transistor T1 is held in a non-conducting state by the negative current taken from -FW through R28, If the ac mains voltage falls to 70% of its minimum value, T1 is switched on, quenching IC1d and input integrator IC1b.

6.2 Partial Load Failure Detection Board

Refer to Figure 6.

This optional circuit is designed to detect a decrease in load current such as due to the failure of one element of a parallel connected load. Alarm state is indicated by a red light-emitting diode (LED) on the front panel and a relay output. The relay is normally 'fail safe' in that it is energised when the load is healthy.

The dc supply for this circuit is obtained through capacitive dropper C10/C11 and bridge rectifier D10, D11, D12, D13, smoothed by C102. This provides +13V and -13V lines, with the junction of Z2 and Z3 being taken to the 0V line of the current transformer. IC1A is used as a buffer and scaler for the current signal which is derived from the current transformer. A half-wave system is used to prevent errors due to unequal numbers of positive and negative half cycle.

IC1B is used as a comparator integrating the sum of the current and voltage signals. The phasing of the current transformer is arranged so that the two half-wave signals coincide. The voltage signal comes via R28, R27, R26 and D15. The output is held negative to switch on T3 which energises the relay coil. In the event of a partial load failure condition, the comparator will switch positively, turning off T3, which releases the relay and lighting LED2 the Load Fail lamp. Link 7 is fitted as standard, and gives fail-safe operation (option 37). Link 6 is fitted for non-fail-safe operation (option 83).

PLF Adjustment

P1 is adjusted on a normal load so that the LED lights and is then set to just extinguish. The integrator provides a short delay to prevent alarms due to transients.

6.3 Feedback and Current Limit Board

Refer to Figure 10.

6.3.1 Feedback Circuit

A simulated load voltage is generated from -FW by IC2a gated with the firing signal (IC1c pin 8). This signal is converted by rms convertor circuit T1 and associated components to a current equivalent to the rms load voltage which is fed back to the input integrator.

6.3.2. Current Limit Circuit (Phase Angle only) (Figure 10)

The load current signal is obtained from a current transformer, rectifier diodes D5 to D8 and burden resistors R60, R75. The rectified current signal is converted to an equivalent rms current by T1 and associated components (two break-point rms converter). This is then compared by integrator IC1b (Motherboard) to the set point inputs auto or manual. If the load current exceeds the set point value, IC1b output will go positive, limiting the thyristor firing angle.

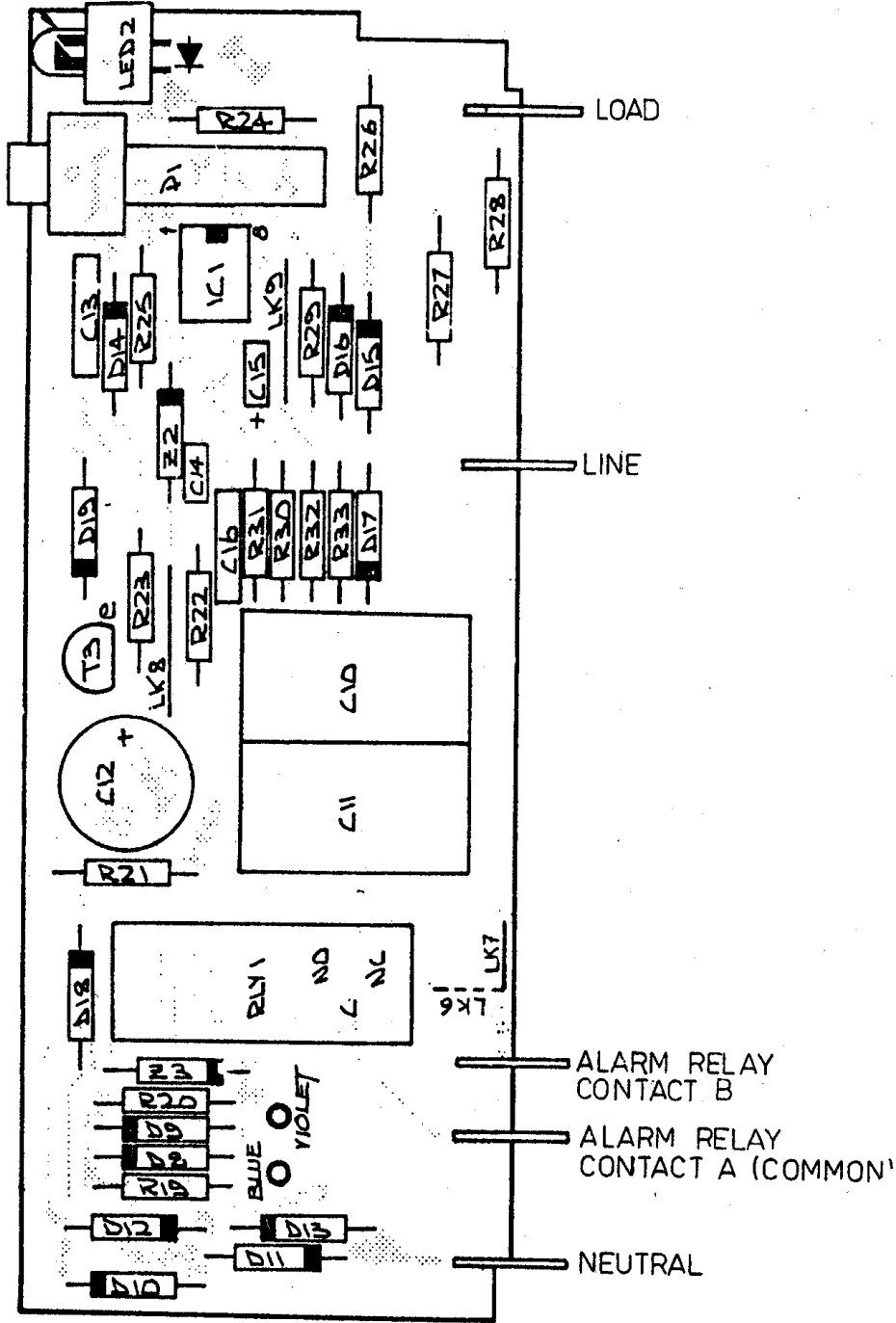

Figure 5 Eurocube (SSC) P.L.F. Board - Layout

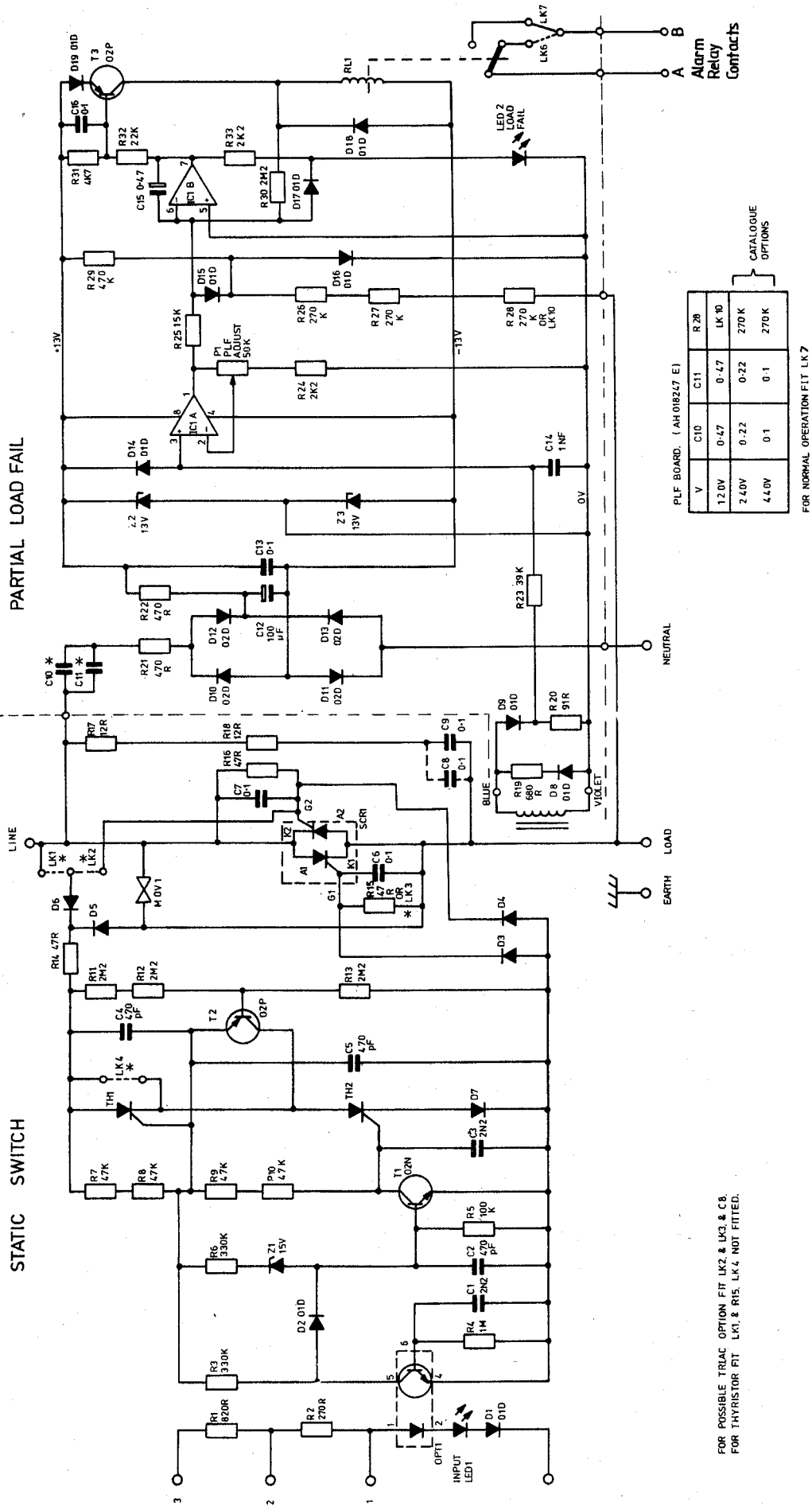

Figure 6 Eurocube (SSC) 425/426 Mother Board - Circuit Diagram Dry. No. AI018246 Iss 3

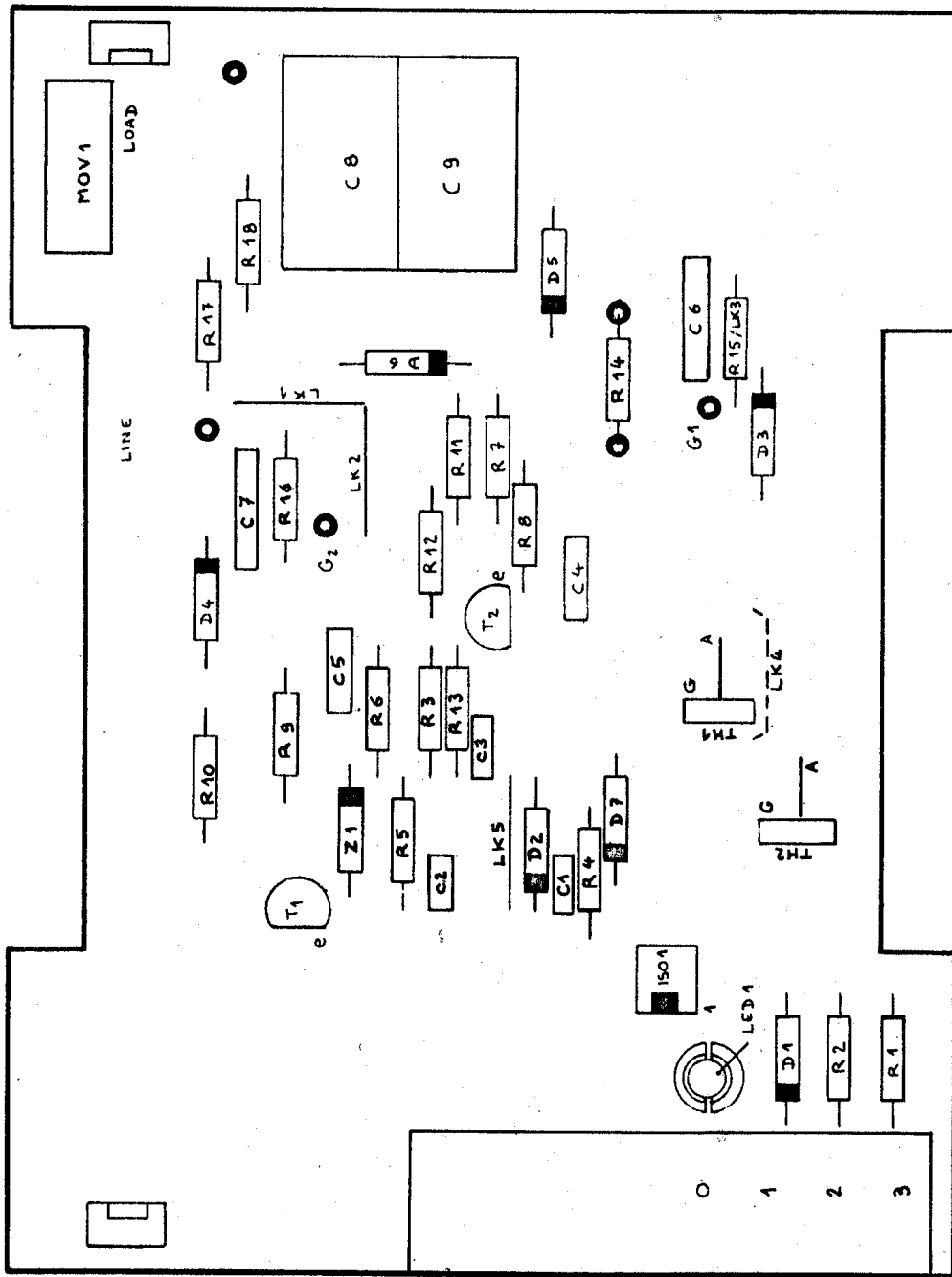
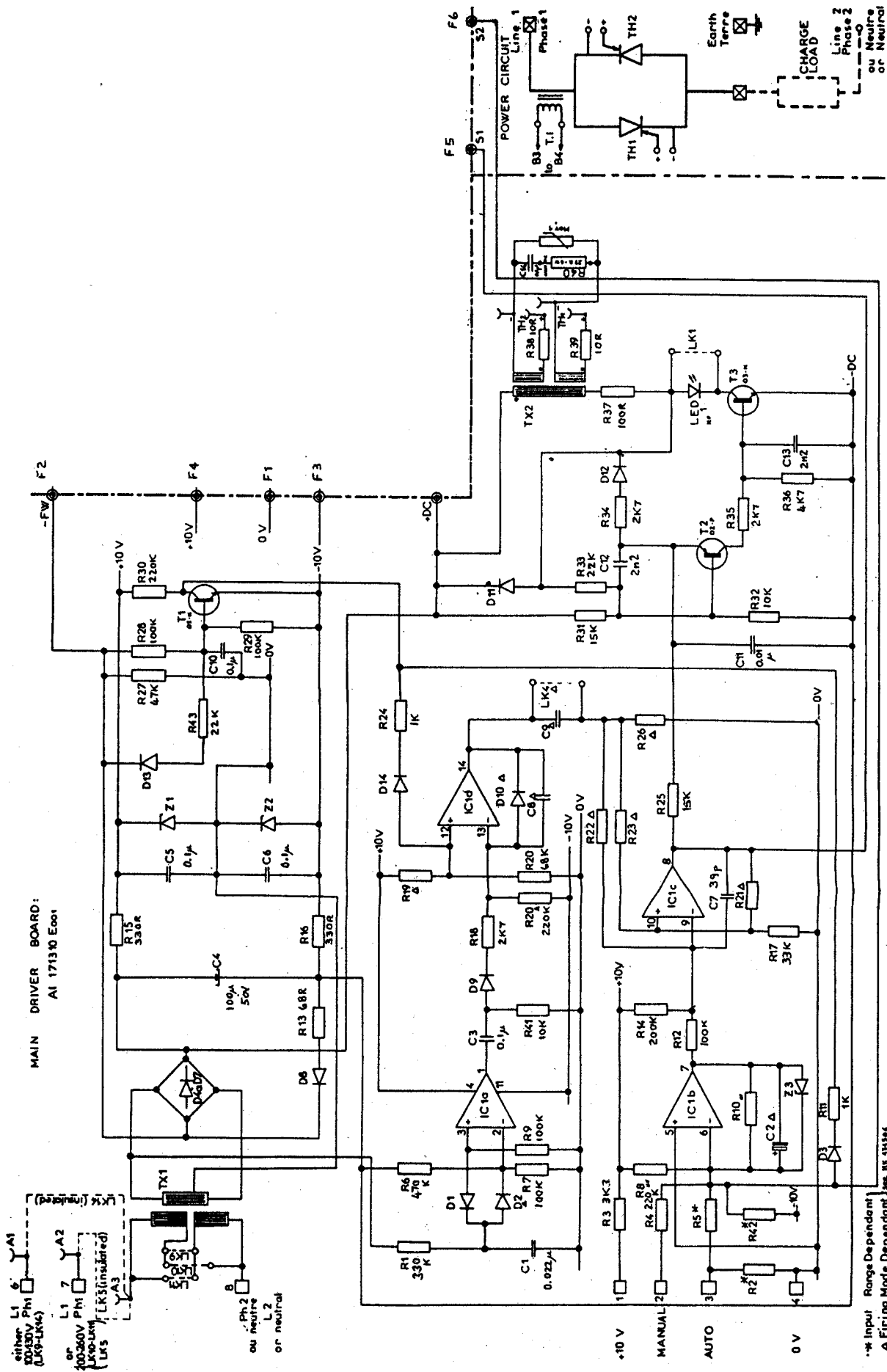

Figure 7 Eurocube (SSC) 425/426 Mother Board - Layout Drg. No. AL018246 Iss 4



MAIN DRIVER BOARD:
AI 171310 E001

either
200-250V Ph1
(LKS(LKS))
or
200-250V Ph1
(LKS(LKS))
L1 6
L2 7
L3 8
L4 9
L5 10
L6 11
L7 12
L8 13
L9 14
L10 15
L11 16
L12 17
L13 18
L14 19
L15 20
L16 21
L17 22
L18 23
L19 24
L20 25
L21 26
L22 27
L23 28
L24 29
L25 30
L26 31
L27 32
L28 33
L29 34
L30 35
L31 36
L32 37
L33 38
L34 39
L35 40
L36 41
L37 42
L38 43
L39 44
L40 45
L41 46
L42 47
L43 48
L44 49
L45 50
L46 51
L47 52
L48 53
L49 54
L50 55
L51 56
L52 57
L53 58
L54 59
L55 60
L56 61
L57 62
L58 63
L59 64
L60 65
L61 66
L62 67
L63 68
L64 69
L65 70
L66 71
L67 72
L68 73
L69 74
L70 75
L71 76
L72 77
L73 78
L74 79
L75 80
L76 81
L77 82
L78 83
L79 84
L80 85
L81 86
L82 87
L83 88
L84 89
L85 90
L86 91
L87 92
L88 93
L89 94
L90 95
L91 96
L92 97
L93 98
L94 99
L95 100

Figure 8 Eurocube (PA, FC, SC) Mother Board - Circuit Diagram Drg. No. AI171310 Iss 3

* Input Range Dependent
Δ Firing Mode Dependent

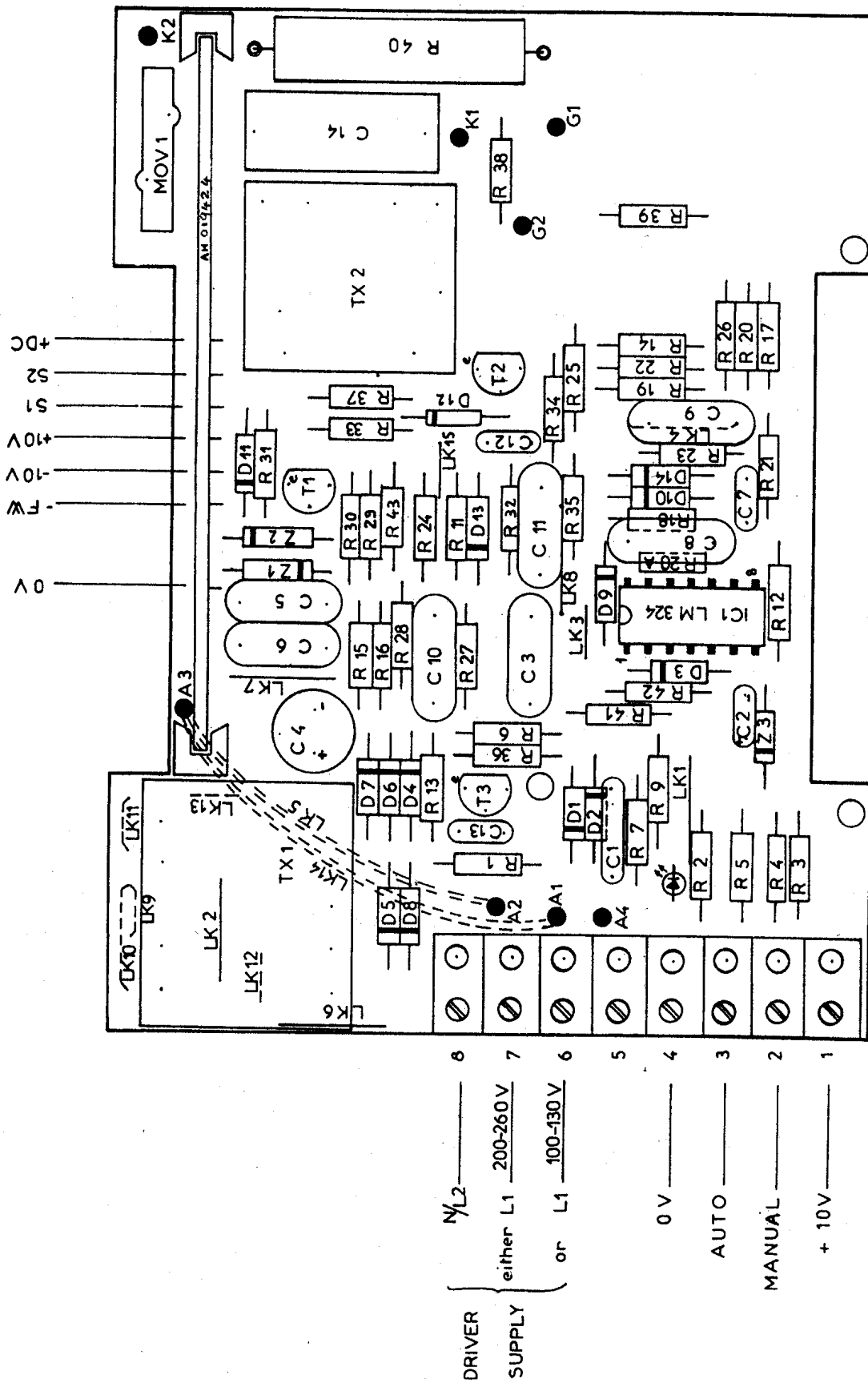

Figure 9 Eurocube (PA, FC, SC) Mother Board - Layout Issue 2 Drg. No. AL171310 Iss 2

INPUT RANGE DEPENDENT COMPONENTS

Input Code	Input Range	R2	R5	R42
008	0-5V	100K	330K	15M0
060	0-10V	100K	680K	15M0
068	1-5V	100K	220K	1M8
069	0-5mA	1K	330K	15M0
071	0-10mA	470R	270K	15M0
072	0-20mA	270R	330K	15M0
073	4-20mA	270R	270K	2M2

FIRING MODE DEPENDENT COMPONENTS

Comps	002 Phase-Angle	001 Fast Cycle	005 Slow Cycle
CA02	0.47uF 35V	0.47uF 35V	10uF 35V
CA08	0.1uF 250V	N.F.	N.F.
CA09	N.F.	0.01uF 250V	0.01uF 250V
DI10/DI02	150V 280mA	N.F.	N.F.
LK04	1/2" Link	N.F.	N.F.
RE 19	N.F.	10K	10K
RE 21	N.F.	150K	150K
RE 22	N.F.	1M2	1M2
RE 23	15K	N.F.	N.F.
RE 26	N.F.	10K	10K

N.F. = not fitted

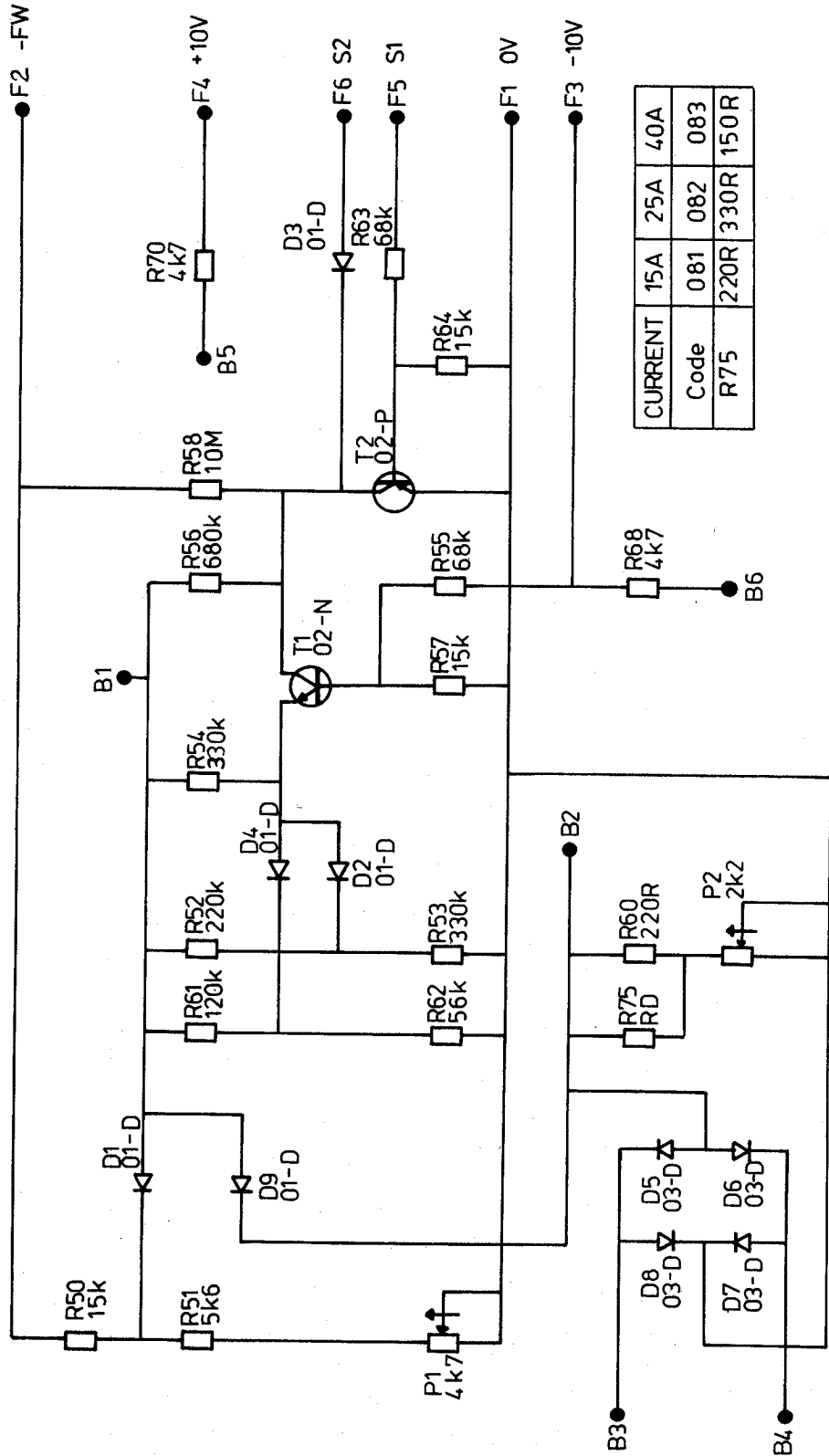

CURRENT	15A	25A	40A
Code	081	082	083
R75	220R	330R	150R

Figure 10 Voltage Feedback and Current Limit Board - Circuit Diagram (Revised) Drg. No. AI019424 Iss B1

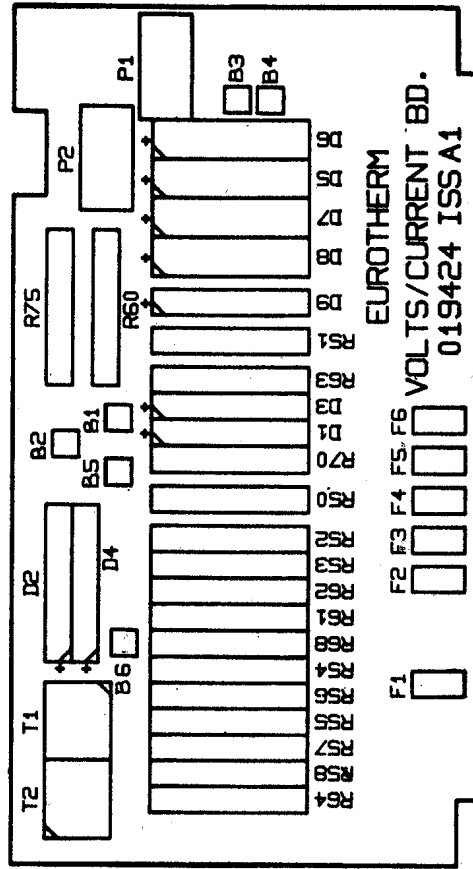

Figure 11 Voltage Feedback and Current Limit Board - Layout (Revised)

INPUT CIRCUIT

CIRCUIT D'ENTREE

ZERO VOLT STATIC SWITCH

CIRCUIT DECLENCHEMENT AU ZERO VOLT

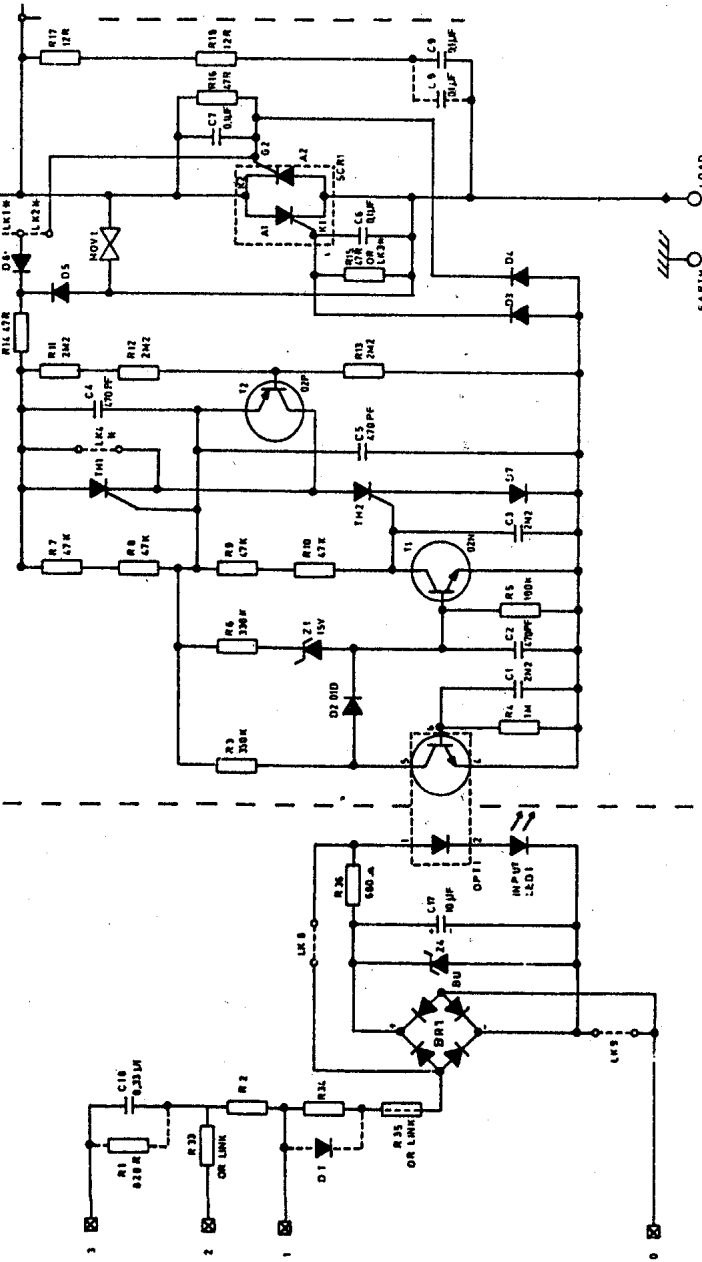

	R7-R8	TH1	LK4	C5	T2	R11-12-13	LK1	LK2	R15	LK3	C6
120V TRIAC	LINK	NF	F	NF	NF	NF	NF	F	NF	F	NF
120V THYRISTORS	LINK	NF	F	NF	NF	NF	NF	F	NF	F	NF
240V THYRISTORS	47K	F	NF	F	F	F	F	NF	F	NF	F
INPUT	C18	R1	R33	R34	R2	D1	R35	Z4	C17	D20+D23	LK8-LK9
LOGIC DC 5V 20V 20mA	NF	820R/LINK	NF	270R	NF	F	LINK	NF	NF	NF	F
LOGIC AC 24V 48V 120/240V	0.33uF	NF	330R	330R	330R	NF	330R 1/2W	F	F	F	NF

F: FITTED NF: NOT FITTED

TRIAC CONNECTIONS

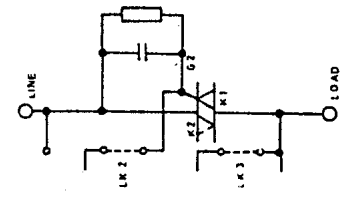

Figure 12 Eurocube 424 (SSC) Motherboard - Circuit Diagram

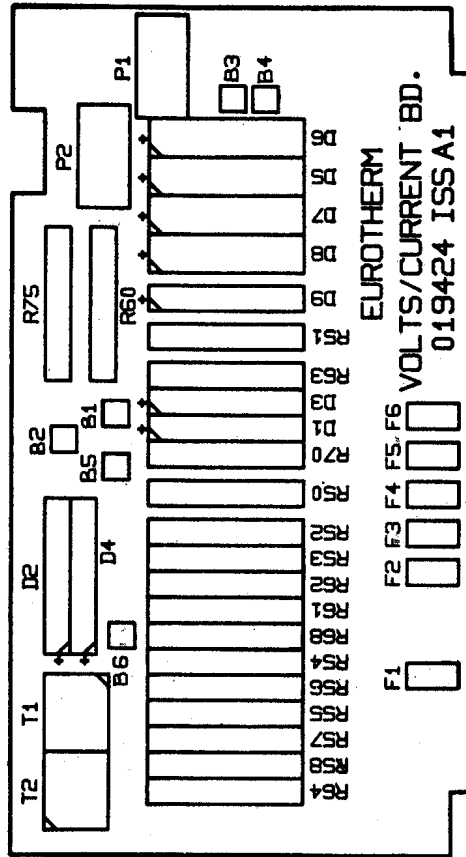

Figure 11 Voltage Feedback and Current Limit Board - Layout (Revised)

INPUT CIRCUIT

CIRCUIT D'ENTREE

ZERO VOLT STATIC SWITCH

CIRCUIT DECLENCHEMENT AU ZERO VOLT

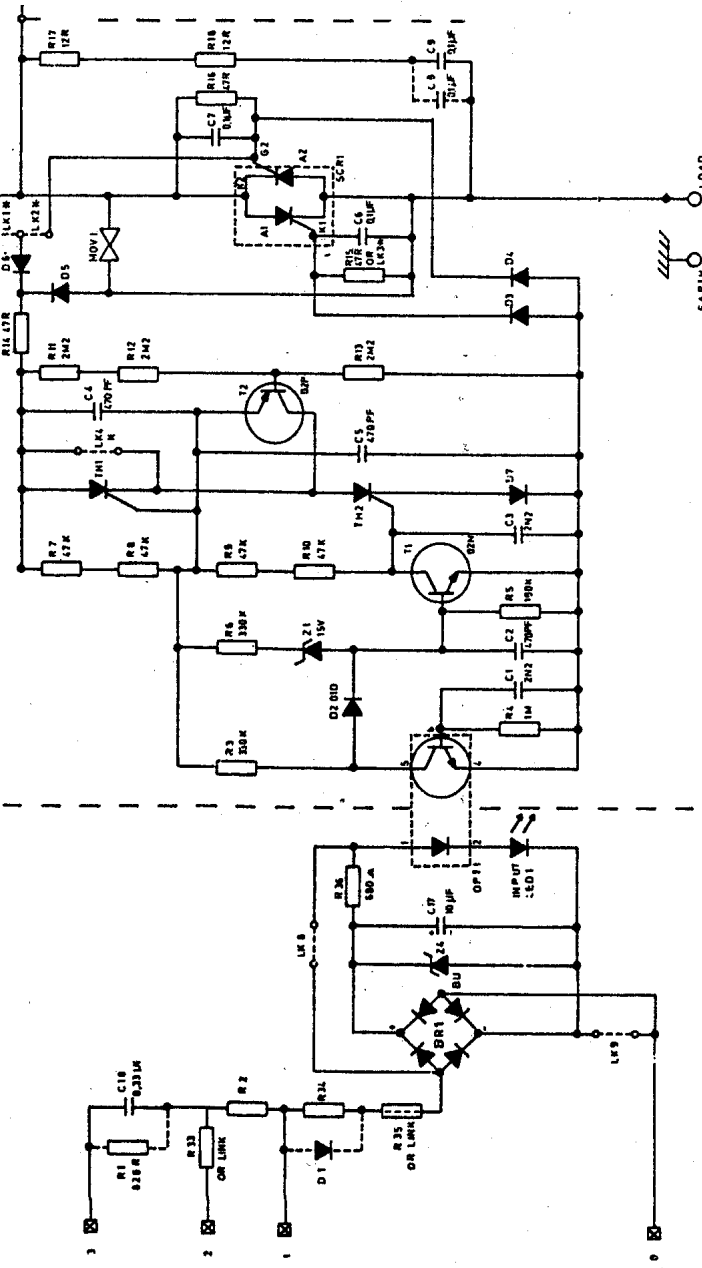

	R7-R8	TH1	LK4	C5	C6	T2	R11-12-13	LK1	LK2	R15	LK3	C6
120V 240V TRIAC	LINK	NF	F	NF	NF	NF	NF	NF	F	NF	F	NF
120V THYRISTORS	LINK	NF	F	NF	NF	NF	NF	NF	F	NF	F	NF
240V 440V THYRISTORS	47K	F	NF	F	F	F	F	F	F	NF	F	NF

INPUT	C18	R1	R33	R34	R2	D1	Z4	C17	D20-D23	LK8-LK9
LOGIC DC 5V 20V 20mA	NF	620R	LINK	NF	270R	F	LINK	NF	NF	F
LOGIC AC 24V 48V 120/240V	0.33uF	NF	330R	330R	330R	NF	330R	1/2W	1/2W	NF

F: FITTED NF: NOT FITTED

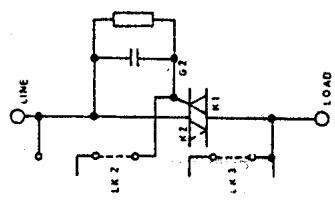

TRIAC CONNECTIONS

Figure 12 Eurocube 424 (SSC) Motherboard - Circuit Diagram

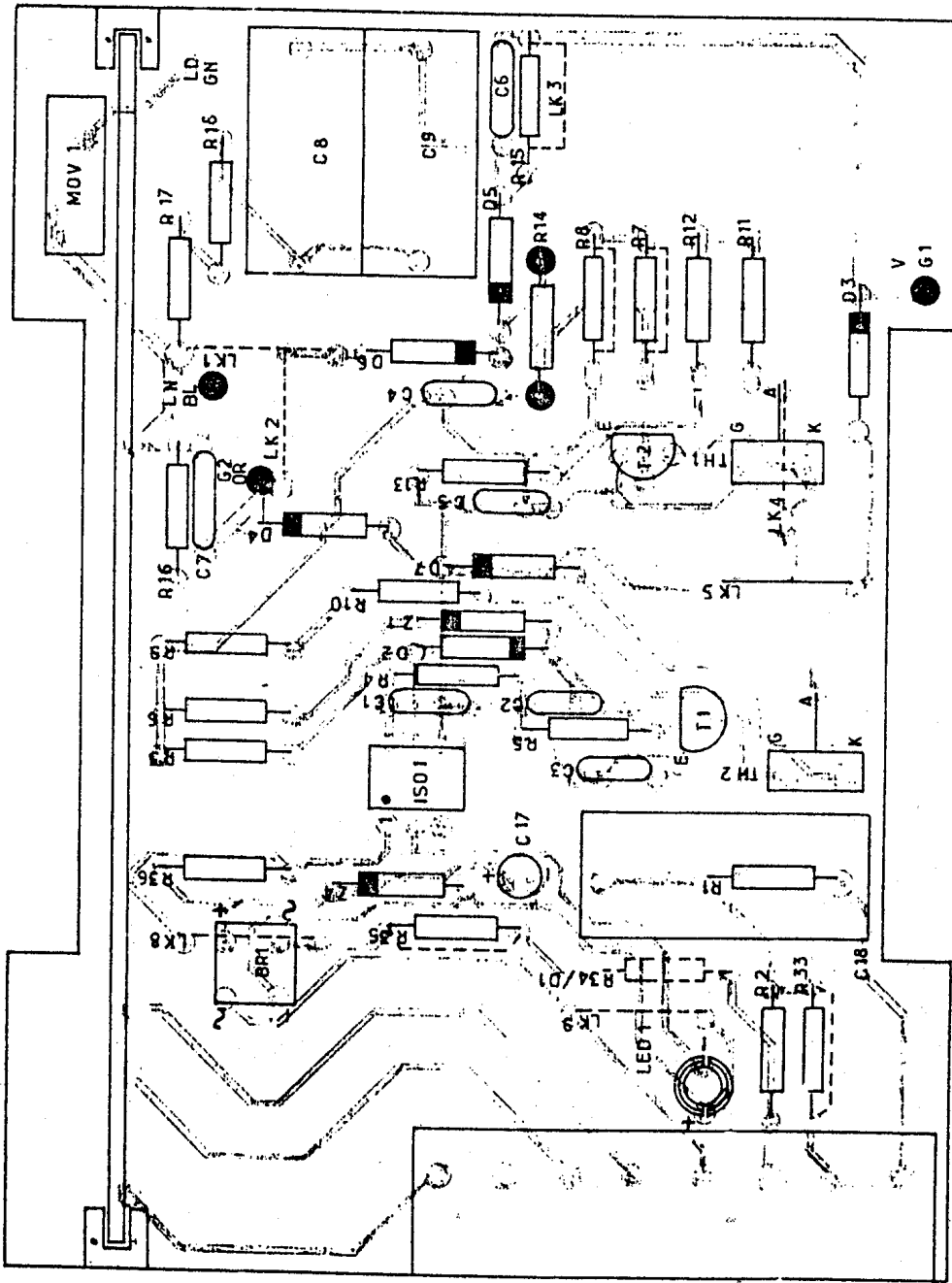

Figure 13 Eurocube 424 (SSC) Motherboard - Layout

Manual Illustration

7.0 DISMANTLING INSTRUCTIONS

The Eurocube is clipped together by four lugs on the rear cover moulding. Switch off the ac supply and remove the Eurocube from its baseplate.

TAKE CARE - THE HEATSINK MAY BE HOT IF THE STACK HAS BEEN RUNNING

Unclip the two lugs either side of the heatsink and remove the rear cover moulding. The printed circuit board is now free on its connecting wires, which are push-on types. If the PLF version is supplied, the PLF board is soldered to the motherboard at right-angles, in card-guides. The current transformer required for this version is a push-fit into a groove in the body moulding.

When re-assembling, take care to position the PLF board potentiometer (if fitted) in the front panel hole. The motherboard may need to be pushed into position when the assembly is clipped together.

8.0 SUGGESTED SPARES

The table below identifies some of the spare parts, together with their Eurotherm part numbers, which may be useful for servicing these units. Please refer to the exploded view when ordering mechanical parts.

Fuses for the 409 fuseholder (10 x 38mm cartridge type) and for the 408 fuseholder (14 x 51mm cartridge type):-

Eurocube Rating	Fuse Rating	Ferraz Type No.	Eurotherm Part No.
15A (409)	20A	600CP URB 10 20	CH260024
25A (409)	30A	600CP URB 10 30	CH260034
40A (408)	50A	600CP URL 14 50	CH330054
SCR1, SCR2	15A/240V 25A/240V 25A/240V 15A/440V 25A/440V		CF018549 CF018550 CF018550 CF018404 CF018405
Potentiometer	Cermet Vertical 4K7		PCV472
Potentiometer	Vertical 10K		PDV103
Potentiometer	50K Multi-turn		CG04450K
Zener Diode	13V 1.3W		CC211130
Zener Diode	15V		CC201151
Diode	150V 200mA		CC101B15
Diode	BYX10		CC104A28
Diode	1N4002		CC103A24
Diode	1800V 1A plastic		CC121A2H
Transistor	02P		CRS000502
Transistor	02N		CRS000002
Transistor	03P		CRS000503
Dual Op Amp	358N		CO1000006

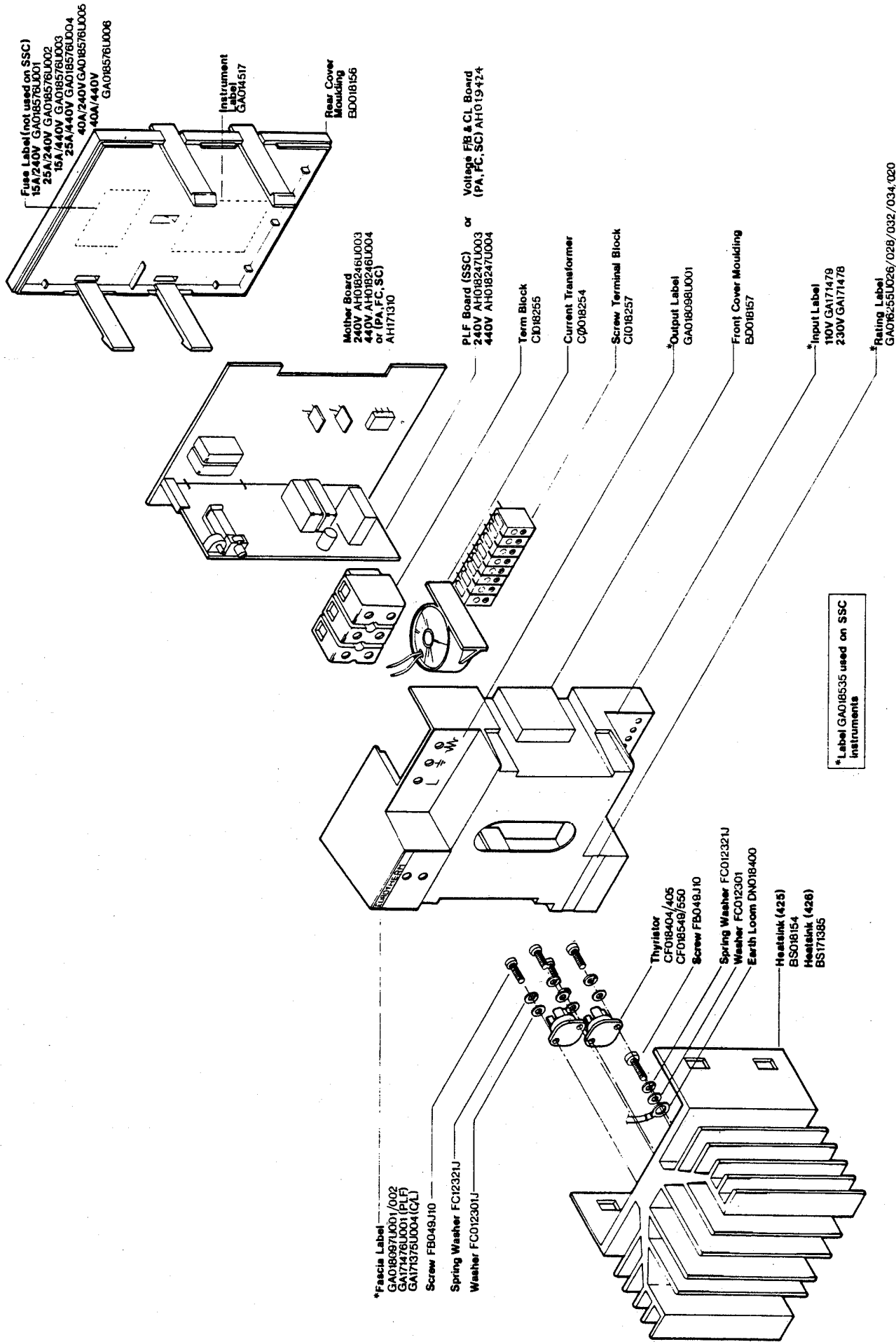

Figure 14 Eurocube Exploded View

Op Amp LM324	CQ1000005
Relay 4kV Isolation	DB017586
Opto-Isolator	CR400012
LED Xciton MV5074 Red 5075	CE019806
Transient Clipper (MOV Device) 240V Board	VDR 275
440V Board	CK016501
Sensitive Gate Thyristor TH1, TH2	CF016262
Bridge Rectifier BR1	CW171607
Terminal Block 8-way screw	CI018257
3-way screw	CI018225
Motherboard 240V SSC Logic Input	AH018246U003
440V SSC Logic Input	AH018246U004
240V SSC AC Input (424)	AH171684U002
PLF Board 240V SSC	AH018247U003
440V SSC	AH018247U004
Motherboard PA	AH171310U002
FC	AH171310U003
SC	AH171310U001
Voltage F/B & Current Limit Board 15A	AH019424U002
25A	AH019424U003
40A	AH019424U004
Pulse Transformer (PA, FC, SC)	CO017656
Current Transformer	CO018254
Mains Transformer	CO017342
Eurocube Mounting Plate	BA018155
Assymetric DIN Rail (484.2mm long)	BA016165
Fixing Brackets (2 per unit requ.) for Assy DIN	BD018267
Fixing Brackets (2 per unit requ.) for Sym DIN	BA018266
Assymetric Mounting Kit	LA171394