

User guide

Model 5100e

100 mm graphics recorder



Declaration of Conformity

Manufacturer's name:	Eurotherm Limited
Manufacturer's address	Faraday Close, Worthing, West Sussex, BN13 3PL, United Kingdom.
Product type:	Industrial graphics recorder
Models:	5100e Status level A1 and above
Safety specification:	EN61010-1: 1993 / A2:1995
EMC emissions specification:	EN61326
EMC immunity specification:	EN61326

Eurotherm Limited hereby declares that the above products conform to the safety and EMC specifications listed. Eurotherm Limited further declares that the above products comply with the EMC Directive 89 / 336 / EEC amended by 93 / 68 / EEC, and also with the Low Voltage Directive 73 / 23 / EEC

Signed:

Dated:

16-03-2001

Signed for and on behalf of Eurotherm Limited

Peter de la Nougerède
(Technical Director)

IA249986U580 Issue 1 Jan 2001

© 2004 Eurotherm Limited

All rights are strictly reserved. No part of this document may be reproduced, modified, or transmitted in any form by any means, nor may it be stored in a retrieval system other than for the purpose to act as an aid in operating the equipment to which the document relates, without the prior written permission of Eurotherm limited.

Eurotherm Limited pursues a policy of continuous development and product improvement. The specifications in this document may therefore be changed without notice. The information in this document is given in good faith, but is intended for guidance only. Eurotherm Limited will accept no responsibility for any losses arising from errors in this document.

GRAPHICS RECORDER

USER MANUAL

LIST OF SECTIONS

Section	Page
1 INTRODUCTION	8
2 INSTALLATION	8
3 PROCESS VARIABLE DISPLAY	12
4 SETTING UP THE RECORDER	34
5 FILE	97
ANNEX A SPECIFICATION	101
ANNEX B REFERENCE	107
INDEX	123

EFFECTIVITY

This manual refers to recorders fitted with software version 3.3. To determine the software version fitted to the recorder, the 'About' screen in the System menu may be accessed as described in [section 4.6.5](#).

For details of Remote Viewer and Modbus Communications see HA028122.

For details of Software and Hardware options see HA028121.

GRAPHICS RECORDER

USER MANUAL

LIST OF CONTENTS

Section	Page
Safety Notes	7
SYMBOLS USED ON THE RECORDER LABELLING	7
1 INTRODUCTION	8
1.1 UNPACKING THE RECORDER	8
2 INSTALLATION	8
2.1 MECHANICAL INSTALLATION	8
2.2 ELECTRICAL INSTALLATION	10
2.2.1 Signal wiring	10
CONNECTOR WIRING DETAILS	10
2.2.2 Supply voltage wiring	11
LINE SUPPLY	11
LOW VOLTAGE SUPPLY OPTION	11
2.3 DISK INSERTION AND REMOVAL	11
3 PROCESS VARIABLE DISPLAY	12
TRUNCATION OF NUMERIC VALUES	13
CURRENT CHANNEL ALARM ICONS	13
3.1 STATUS BAR	13
3.1.1 Current access level	13
3.1.2 Page name	13
3.1.3 Alarm indicators	14
ALARM SUMMARY PAGE	14
ALARM ACKNOWLEDGEMENT	15
INSTRUMENT ALARMS	16
CHANNEL ALARM	17
CHANGE BATTERY	17
3.1.4 Disk icon	17
3.1.5 FTP Icon	17
3.1.6 Configuration Locked indicator	17
3.2 NAVIGATION Keys	18
3.2.1 Key functions	18
MESSAGE LOG	19
3.3 FIRST SWITCH-ON	21
3.3.1 Access to Configuration	22
TEXT STRING ENTRY	23
3.4 DISPLAY MODES	25
3.4.1 Vertical Trend display	25
TIME CHANGE RECORDS	26
TREND HISTORY	26
3.4.2 Horizontal Trend display	28
3.4.3 Vertical bargraph	30
3.4.4 Horizontal bargraph	31
3.4.5 Numeric	32
3.5 OPERATOR NOTES	33

LIST OF CONTENTS (Cont.)

Section	Page
4 SETTING UP THE RECORDER	34
4.1 ARCHIVE	35
4.1.1 Archive to disk	35
4.1.2 Remote archiving (FTP transfer)	36
4.2 SAVE / RESTORE	37
4.2.1 Save	38
SAVE FOR PRE VERSION 1.8	38
4.2.2 Restore	38
4.2.3 New	38
4.2.4 Text	38
4.2.5 Import User Linearisation	39
4.2.6 Export User Linearisation	39
4.3 CONFIGURATION	40
4.3.1 Instrument configuration	43
INSTRUMENT NAME	43
NORMAL/SAVER DISPLAY	43
SAVE AFTER	43
MODBUS ADDRESS	43
MODBUS SECURITY DISABLED	43
COMMS CHANNEL TIMEOUT	43
PRESET HOUR	43
PRESET MINUTE	43
4.3.2 Group configuration	44
GROUP NUMBER	44
TREND UNITS	44
DESCRIPTOR	44
A/B SWITCHING	44
TREND SPEED/TREND INTERVAL	45
GRID TYPE	45
RECORDING ENABLE	46
RECORDING SPEED/RECORDING INTERVAL	46
TREND HISTORY DURATION	46
ARCHIVE TO MEDIA/ARCHIVE VIA FTP	46
ALARM MESSAGE	46
ACK MESSAGE	47
GROUP CONTENTS	47
4.3.3 Channel/Alarm configuration	48
CHANNEL NUMBER	49
VALUE	49
INPUT TYPE	49
LIN TYPE	49
INPUT LOW	49
INPUT HIGH	49
SHUNT	49
RANGE LOW	50
RANGE HIGH	50
RANGE UNITS	50
SCALED	50
OFFSET	50
SCALE TYPE	50
FILTER	51
BREAK RESPONSE	52
COLD JUNCTION COMPENSATION (CJC)	52
DESCRIPTOR	52
A/B SWITCHING	52
SPANNED	52
ZONE	53
PV FORMAT	53

Cont...

LIST OF CONTENTS (Cont.)

Section	Page
4.3.3 Channel/Alarm Configuration (Cont.)	
MAXIMUM DECIMAL DIGITS	53
COLOUR	53
ALARM NUMBER	54
ENABLE	54
TYPE	54
PARAMETERS	55
EXAMPLE	55
JOB NUMBER	57
CATEGORY	57
WHILE/ON	57
ALARM MESSAGES	57
4.3.4 Views Configuration	58
HOME TIMEOUT	58
HOME GROUP	58
DARK TREND/DARK HISTORY BACKGROUND	58
SCOPE	59
GROUP	59
DISPLAY ENABLED	59
HOME PAGE	59
DISPLAY MODE ENABLING	59
4.3.5 Archive configuration	60
COMPRESSION	61
FLASH SIZE	61
SHORTEST TREND HISTORY / DURATION	61
CSV CHECKBOXES, DATE/TIME FORMAT	61
SHOW	61
ARCHIVE TO MEDIA	61
MEDIA FILE FORMAT/FTP FILE FORMAT	61
MEDIA FULL OPERATION	62
MEDIA SIZE	62
DISK ARCHIVE CAPACITY	62
MEDIA FULL EVENT LIMIT	62
ARCHIVE TO REMOTE	62
REMOTE PATH	62
PRIMARY REMOTE HOST	63
PRIMARY LOGIN NAME/PASSWORD	63
SECONDARY REMOTE HOST/LOGIN/PASSWORD	63
CSV OPTION	63
4.3.6 Event configuration	65
EVENT NUMBER	65
SOURCE TYPES	65
SOURCE 1 SENSE	66
OPERATOR	66
SOURCE 2 SENSE	66
DESCRIPTOR	67
JOB NUMBER	67
CATEGORY	67
WHILE/ON	67
EVENT EXAMPLE	67
4.3.7 Messages	68
MESSAGE ENTRY	68
CONFIGURABLE PARAMETERS	68
EXAMPLE	70
4.3.8 User Linearisation Tables	71
CONFIGURATION PARAMETERS	71
4.3.9 Options	73

Cont...

LIST OF CONTENTS (Cont.)

Section	Page
4.4 SECURITY	74
4.4.1 Access levels	74
SETTING PERMISSIONS	75
ACCESS WHEN:	75
NEW PASSWORD/RETYPE PASSWORD	75
CONNECT FROM REMOTE	75
REMOTE USER NAME/PASSWORD	76
LOGIN DISABLED	76
EDIT OWN PASSWORD	76
CHANGE ALARM SETPOINTS	76
ACKNOWLEDGE ALARMS	76
EDIT MATHS CONSTANT	76
PRESET TOTALISERS	76
PRESET COUNTERS	76
START/RESET TIMERS	76
SET CLOCK	76
ADJUST INPUTS	77
ARCHIVING CONTROL	77
SAVE/RESTORE	77
PASTE/DELETE FILES	77
FULL CONFIGURATION	77
FULL SECURITY	77
EVENT PERMISSION 1	77
EVENT PERMISSION 2 TO 5	77
FORCE CHANGE OF PASSWORD	77
4.4.2 Management (option)	78
4.4.3 Add user	79
NEW USER ID	79
NEW FULL USER NAME	79
NEW PASSWORD/RETYPE PASSWORD	79
BASED ON	79
4.4.4 Remove user	79
4.5 NETWORK CONFIGURATION	80
4.5.1 Address	80
INSTRUMENT NUMBER/MAC ADDRESS	80
IP ADDRESS LOOKUP	80
BOOTP TIMEOUT	80
IP ADDRESS	80
SUBNET MASK	81
DEFAULT GATEWAY	81
SNTP ENABLE	81
SNTP SERVER	81
4.5.2 Name	82
LOCAL HOST	82
DOMAIN	82
DOMAIN NAME SERVICE (DNS)	82
PRIMARY/SECONDARY DNS SERVER	82
4.6 SYSTEM	83
4.6.1 Clock	84
4.6.2 Locale	84
4.6.3 Keycode	84
4.6.4 Input adjust	84
ADJUST PROCEDURE	86
4.6.5 About	87
INSTRUMENT VARIANT	87
CONFIG REVISION	87
SECURITY REVISION	87
SUPPORT FILE	88
CLEAN \USER FOLDER	88

Cont...

LIST OF CONTENTS (Cont.)

Section	Page
4.6.6 Copy	89
CONFIGURABLE PARAMETERS	89
COPY RULES	90
4.7 JOBS	91
4.7.1 No Action	91
4.7.2 Drive relay	91
4.7.3 Totaliser category	91
4.7.4 Message category	92
4.7.5 Maths Category	92
4.7.6 Clock category	93
4.7.7 Counter category	93
4.7.8 Timer jobs	94
4.7.9 Recording jobs	94
4.7.10 Trend jobs	95
4.7.11 Alarm jobs	95
4.7.12 Archive jobs	96
4.7.13 Email category	96
5. FILE	97
5.1 FILER OPTION MENU KEYS	97
5.2 THE HIDE KEY	97
5.3 FILE STRUCTURE	99
5.3.1 Software versions prior to 3.1	99
5.3.2 Software versions 3.1 onwards	99
Annex A: SPECIFICATION	101
TECHNICAL SPECIFICATION (Recorder)	102
TECHNICAL SPECIFICATION (Universal inputs)	104
TECHNICAL SPECIFICATION (Ethernet/Relay output board option)	106
Annex B: REFERENCE	107
B1 DIAGNOSTICS DISPLAY	107
B1.1 DISPLAY DETAILS	107
MAC ETHERNET ADDRESS	107
COLOUR TEST BARS	107
SOFTWARE VERSION NUMBER	107
SELF-TEST STATUS BARS	107
CIRCUIT BOARDS FITTED	108
TOUCH CAL	108
DETAIL	108
B2 SCREEN CALIBRATION (OFFSET CORRECTION)	109
B3 PREVENTIVE MAINTENANCE	109
B3.1 Touch Screen Cleaning	109
B3.2 Maintenance schedule	110
B3.3 Battery replacement procedure	110
B4 OPTION ENABLING	111
B4.1 Instrument Number	111
B4.2 Key Code	111
B4.3 KeyCode File	111
B5 COLOUR SELECTION	112
B6 TCP Port Numbers	114
B7 TIME ZONES	115
B8 MENU STRUCTURE	117
Index	123

SAFETY NOTES

WARNING

Any interruption of the protective conductor inside or outside the apparatus, or disconnection of the protective earth terminal is likely to make the apparatus dangerous under some fault conditions. Intentional interruption is prohibited.

Note: in order to comply with the requirements of safety standard BS EN61010, the recorder shall have one of the following as a disconnecting device, fitted within easy reach of the operator, and labelled as the disconnecting device.







- a. A switch or circuit breaker which complies with the requirements of IEC947-1 and IEC947-3
- b. A separable coupler which can be disconnected without the use of a tool
- c. A separable plug, without a locking device, to mate with a socket outlet in the building.

1. Before any other connection is made, the protective earth terminal shall be connected to a protective conductor. The mains (supply voltage) wiring must be terminated within the connector in such a way that, should it slip in the cable clamp, the Earth wire would be the last wire to become disconnected.
2. In the case of portable equipment, the protective earth terminal must remain connected (even if the recorder is isolated from the mains supply), if any of the I/O circuits are connected to hazardous voltages*.
3. The mains supply fuse within the power supply is not replaceable. If it is suspected that the fuse is faulty, the manufacturer's local service centre should be contacted for advice.
4. Whenever it is likely that protection has been impaired, the unit shall be made inoperative, and secured against accidental operation. The manufacturer's nearest service centre should be contacted for advice.
5. Any adjustment, maintenance and repair of the opened apparatus under voltage, should be avoided as far as possible and, if inevitable, shall be carried out only by a skilled person who is aware of the hazard involved.
6. Where conductive pollution (e.g. condensation, carbon dust) is likely, adequate air conditioning/filtering/sealing etc. must be installed in the recorder enclosure.
7. Signal and supply voltage wiring should be kept separate from one another. Where this is impractical, shielded cables should be used for the signal wiring.
8. If the equipment is used in a manner not specified by the manufacturer, the protection provided by the equipment might be impaired.

* A full definition of 'Hazardous' voltages appears under 'Hazardous live' in BS EN61010. Briefly, under normal operating conditions, hazardous voltages are defined as being > 30V RMS (42.2V peak) or > 60V dc.

SYMBOLS USED ON THE RECORDER LABELLING

One or more of the symbols below may appear as a part of the recorder labelling.

	Refer to the manual for instructions
	Protective earth
	This recorder for ac supply only
	This recorder for dc supply only
	This recorder for either ac or dc supply
	Risk of electric shock

USER MANUAL

1 INTRODUCTION

This document describes the installation, operation and configuration of a 100mm graphics recorder. The recorder has the facility for FTP transfer and Remote viewer connection if the Ethernet option is fitted.

The recorder instrument time can be updated from a unicast (i.e. point-to-point) Simple Network Time Protocol (SNTP) server and is also itself an SNTP server. SNTP time is based on elapsed seconds since 00:00 hrs on 1st Jan 1900 GMT and is affected neither by time zones nor by daylight saving. The relevant TCP port number is 123. See sections 4.3.1 ([Instrument configuration](#)), 4.5.1 ([Network Address configuration](#)) and B6 in Annex B, for more details.

1.1 UNPACKING THE RECORDER

The recorder is despatched in a special pack, designed to give adequate protection during transit. Should the outer box show signs of damage, it should be opened immediately, and the recorder examined. If there is evidence of damage, the instrument should not be operated and the local representative contacted for instructions. After the recorder has been removed from its packing, the packing should be examined to ensure that all accessories and documentation have been removed. The packing should then be stored against future transport requirements.

2 INSTALLATION

2.1 MECHANICAL INSTALLATION

Figure [2.1](#) gives installation details.

Note: It is recommended that the rear face of the panel be centre-punched at suitable positions to locate the tips of the case clamps. Otherwise, particularly on smooth surfaces, the clamps can 'wander' as they are tightened, leading to inefficient clamping and possible damage to the recorder mounting slots.

The unit is inserted through the panel aperture from the front of the panel. With the weight of the recorder supported, a panel clamp is inserted into each of the mounting slots (one each on the left- and right-hand sides). The jacking screws are then tightened sufficiently to clamp the recorder into position. **EXCESS FORCE SHOULD NOT BE USED IN TIGHTENING THESE SCREWS.**

2 INSTALLATION (Cont.)

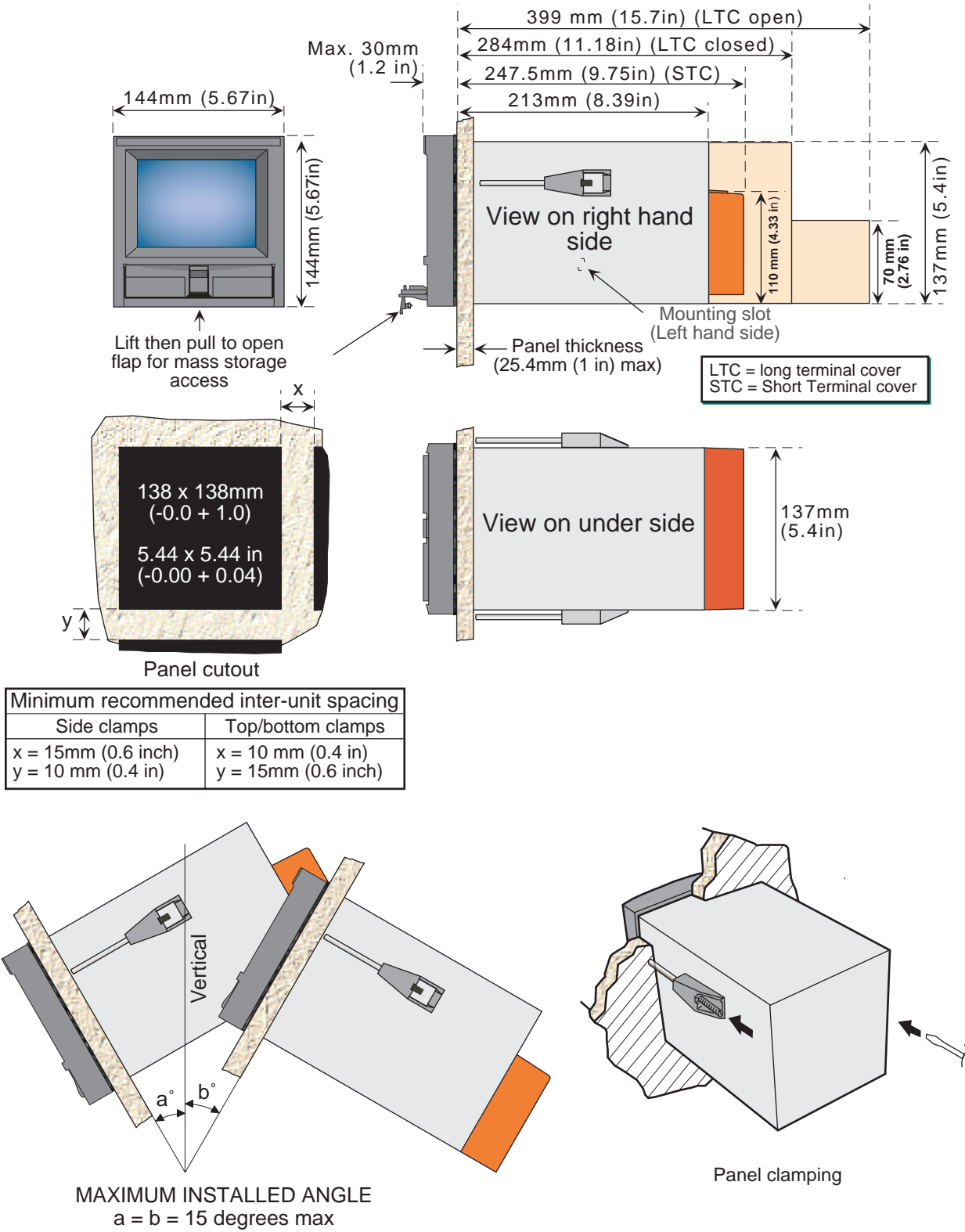

Figure 2.1 Mechanical installation details - small frame unit

2.2 ELECTRICAL INSTALLATION

2.2.1 Signal wiring

Figure 2.2.1a shows connector locations for the input channel and for the optional relay output/Ethernet board

CONNECTOR WIRING DETAILS

- Maximum wire size (inputs) = 4.13mm² (11 AWG)
- Maximum wire size (relay) = 1.5 mm² (16 AWG)
- Max. wire size (non-isolated TRS) = 1.5 mm² (16 AWG)
- Minimum wire size = 0.081mm² (28 AWG)
- Design torque = 0.8Nm.

Figures 2.2.1b, c and d show details of input board wiring, relay output option wiring and Non isolated Transmitter Power supply option pinout, respectively. Wiring details for other options is to be found in the relevant Option description later in the manual.

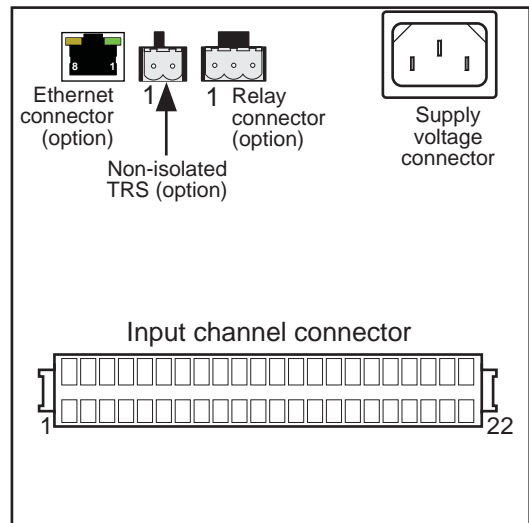

Figure 2.2.1a Connector locations

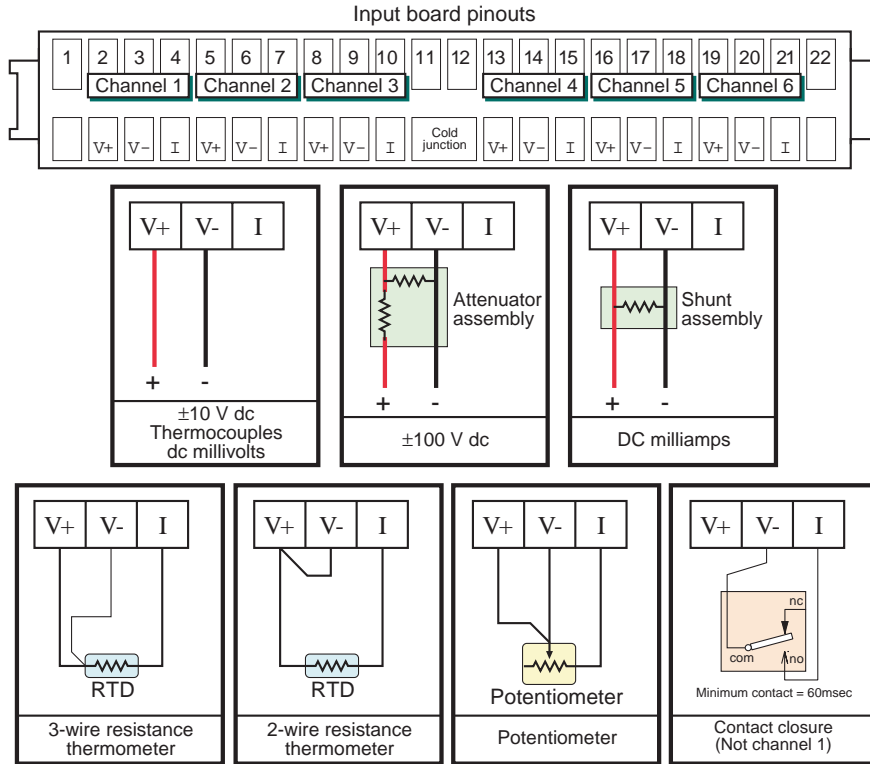

Figure 2.2.1b Input board wiring details

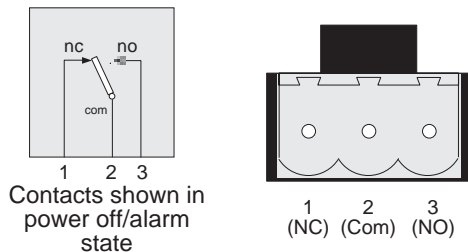

Figure 2.2.1c Relay wiring details

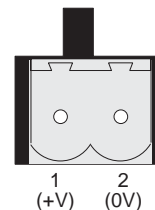

Figure 2.2.1d Non-isolated TRS wiring details

2.2.2 Supply voltage wiring

WARNING

DC supply voltages must never be applied to recorders fitted with isolated transmitter power supplies.

Note: The minimum recommended wire size is 16/0.2 (0.5mm²).

LINE SUPPLY

The supply voltage to the recorder is terminated using an IEC socket which is connected to the mating plug at the rear of the recorder. The recorder is suitable for use with all ac voltages between 85 and 265 V RMS (47 to 63 Hz), and requires 60 VA max. power. For recorders without transmitter power supplies, supply voltages of between 110V dc and 370V dc may also be used.

LOW VOLTAGE SUPPLY OPTION

Not suitable for recorders fitted with the isolated transmitter power supply option.

The low voltage supply option is terminated at a three-pin connector (plug mounted on recorder - socket on supply cable) as shown in figure 2.2.2.

The option allows the use of ac or dc supplies with the following characteristics:

AC: 20 to 42V RMS (45 to 400 Hz)

DC: 20 to 54V (See warning above)

Power: 60VA max.

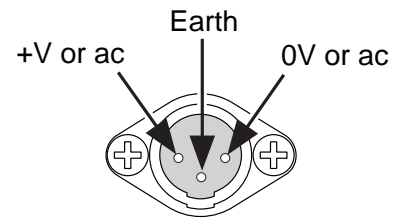

Figure 2.2.2 Low voltage supply pinout

2.3 DISK INSERTION AND REMOVAL

The disk slot is located below the recorder screen, and is protected by a flap as shown in figure 2.1, above.

In order to access the disk slot, the bottom of the central part of the flap is lifted (figure 2.3a) and then used as a handle to pull the main flap open.

If a disk is already fitted, it is removed by pressing on the eject button (figure 2.3b).

Note: Before disk removal, archiving should be suspended ([section 4.1](#)) (wait for the green LED on the disk drive to be extinguished), otherwise data might be lost.

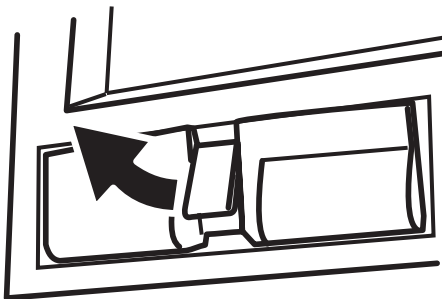

Figure 2.3a Disk access

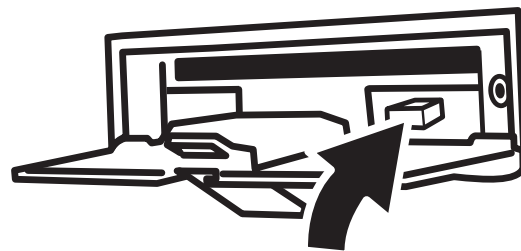

Figure 2.3b Disk eject

3 PROCESS VARIABLE DISPLAY

The operator interface consists of a touch-sensitive screen, showing either process variable values in one of a number of formats, or, showing configuration or operational details for use in setting up the recorder. This section (3) describes the process variable displays. Section 4 describes the Configuration displays.

Figure 3, below, depicts a typical trend display and gives details of the various areas of the display page.

Note: Dialogue boxes, message boxes etc. cause Process Variable displays to 'freeze' for as long as the box is on display. Root and Option menus (amongst others) time-out (i.e. are removed from the display) after approximately one minute. Messages, however, are displayed until the operator takes action to remove them. It should be noted, especially, that several message boxes may be active at one time, but only the oldest one is visible, until it is removed to reveal the 'next oldest' message, and so on.

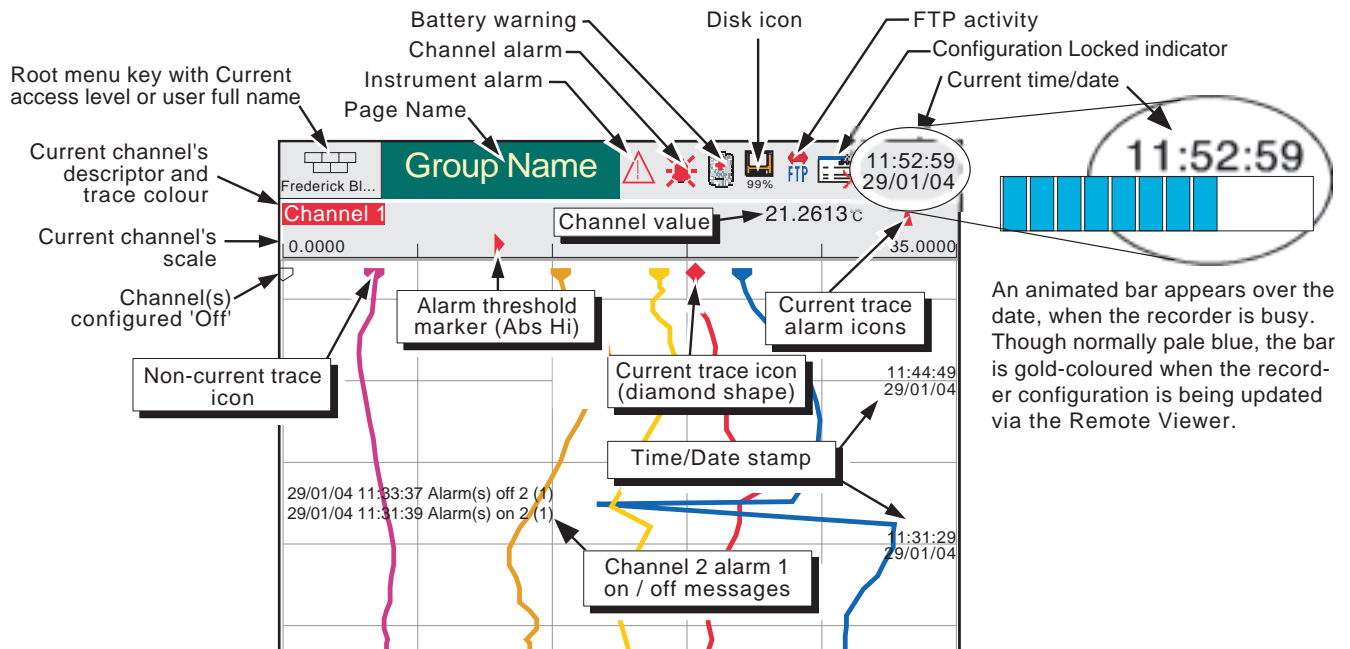

Figure 3 Trend display definitions

3 PROCESS VARIABLE DISPLAY (Cont.)

TRUNCATION OF NUMERIC VALUES

If the amount of space on the display page is insufficient to display the full width of the process variable or scale value, then the displayed value is rounded down and the number of decimal places reduced. If the available space is still too restricted, the value is displayed in 'Scientific' format, or if this is still too wide, the final visible character of the integer part of the display is replaced by a '?'.

CURRENT CHANNEL ALARM ICONS

In each of the different types of PV display, each channel's faceplate give the status of the channel's alarms. This status is shown by one of the icons depicted in table 3, either off, flashing (if it is active and unacknowledged) or on continuously (if it is active and acknowledged). See [section 3.1.3](#), below, for a description of how to acknowledge alarms, and [section 4.3.3](#) for a description of the alarm types. Absolute alarm threshold icons and deviation-alarm bars appear in any display which includes a scale. For deviation alarms, the bar stretches from (Reference - Deviation) to (Reference + Deviation).

Notes

1. For software versions 2.3 onwards, 32MB versions of the recorder come with four alarms per point, instead of two per point as supplied with previous software versions. The System/About display can be used establish what size of DRAM s fitted - see [section 4.6.5](#).
2. 'Trigger' alarms do not display threshold marks or bars, or faceplate symbols.

4-alarm units 2-alarm units

	Absolute High
	Absolute Low
	Deviation in
	Deviation out
	Rate-of-change Rising
	Rate-of-change Falling

Scale symbols

	Absolute low	Absolute high	Deviation In / Out	Rate of change
Horizontal scales				No indication
Vertical scales				No indication

For Deviation alarms, R = Reference; d = deviation

Faceplate symbols

Table 3 Alarm symbols

3.1 STATUS BAR

This appears across the top of the display, and contains the items described below.

3.1.1 Current access level

There are four access levels available (Logged out, Operator, Engineer and Service), and the current level is displayed in this key at the top left hand corner of the display. Touching this key calls the root menu as described in section 3.2.1 ([Key functions](#)) below. If a user has been added in the 'Add User' part of the Security setup ([section 4.4.3](#)), then the 'Full User Name' is displayed (truncated if necessary) instead of the access level.

3.1.2 Page name

Initially this shows the current group's descriptor. The name changes according to context for example 'Operator' or 'Config-Archive'.

3.1.3 Alarm indicators

This area of the display can contain up to four icons: [Instrument alarm](#), [Channel alarm](#), [Battery change](#), [Disk status](#). Pressing this area of the screen calls a pop-up display (figure 3.1.3a) allowing the user to view messages to acknowledge all channel alarms, or to display the Alarm Summary page. Also incorporated in this display is a slider control allowing the user to optimise the display contrast for the local environment. For channel alarm symbols, refer to '[Current Trace Alarm Icons](#)', above.

ALARM SUMMARY PAGE

As shown in figure 3.1.3a, below, the alarm summary page contains the following information:

1. Alarm identifier. This appears as a point ID, followed by the relevant alarm number in parentheses. For example, Alarm 1 on maths channel 6 would appear as: D6 (1). Maths channels are prefixed by 'D'. Totalisers are prefixed by 'T' and Counters are prefixed by 'C'. Input channels are not prefixed.
2. Alarm threshold for absolute alarms only
3. The current process value for the point
4. An alarm symbol (see Table 3). Alarm symbols flash until acknowledged.

Notes:

1. Alarms are always listed in Point/Alarm order with input channels first, followed by derived channels, totalisers and counters, if these options are fitted.
2. When the alarm source returns to its non-alarm state: Unlatched alarms are removed from the list whether or not they have been acknowledged; latched alarms remain displayed until acknowledged. See [section 4.3.3](#) for a description of alarm types and actions.
3. There are no time or history components associated with the Alarm Summary. If Alarm messages have been enabled in the relevant group's configuration ([section 4.3.2](#)), then alarm initiation/acknowledgement times and dates can be found from the trend and trend history displays, described in [section 3.4](#), or in Message log, described in [section 3.2.1](#).
4. If an alarm is active on a channel which is not included in either group, then although the channel alarm symbol will flash, the alarm will not appear in the alarm summary pages.

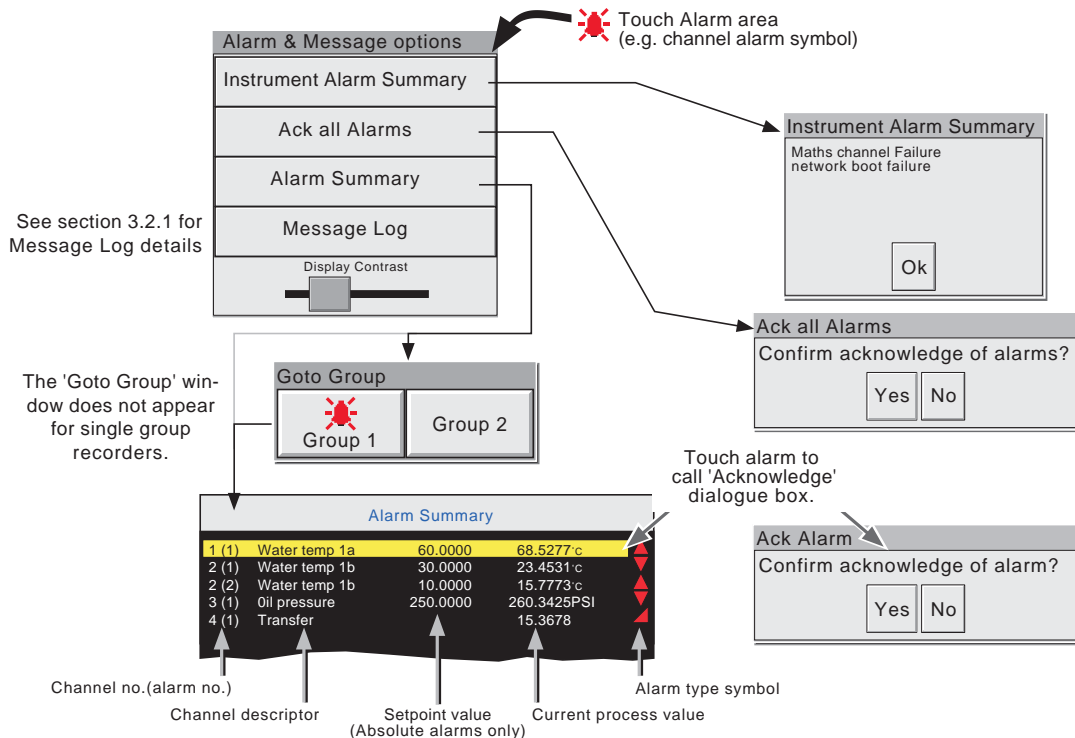

Figure 3.1.3a Alarm and message options display and contrast control

3.1.3 ALARM INDICATORS (Cont.)

ALARM ACKNOWLEDGEMENT

Alarms can be acknowledged globally (all alarms), individually or on a group basis.

ALL ALARMS

To acknowledge all active alarms, touch (e.g.) the channel alarm icon at the top of the screen. From the resulting pop-up menu, select 'Ack all Alarms', then finally, touch 'Yes' in the resulting pop-up confirmation box. Figure 3.1.3a, above, attempts to show this process.

INDIVIDUAL ALARMS

Individual alarms are acknowledged from the alarm summary page by touching the relevant item (highlights yellow), then touching 'Yes' in the resulting pop-up confirmation box. Figure 3.1.3a, above, attempts to show this process.

GROUP ALARMS

For recorders with multiple groups, alarms can be acknowledged on a group basis by calling the alarm summary page for the relevant group, then pressing the Root menu Options key ([section 3.2](#)), the 'Ack Group Alarms' key and finally, 'Yes' in the resulting pop-up confirmation box. Figure 3.1.3b, below, attempts to show this process.

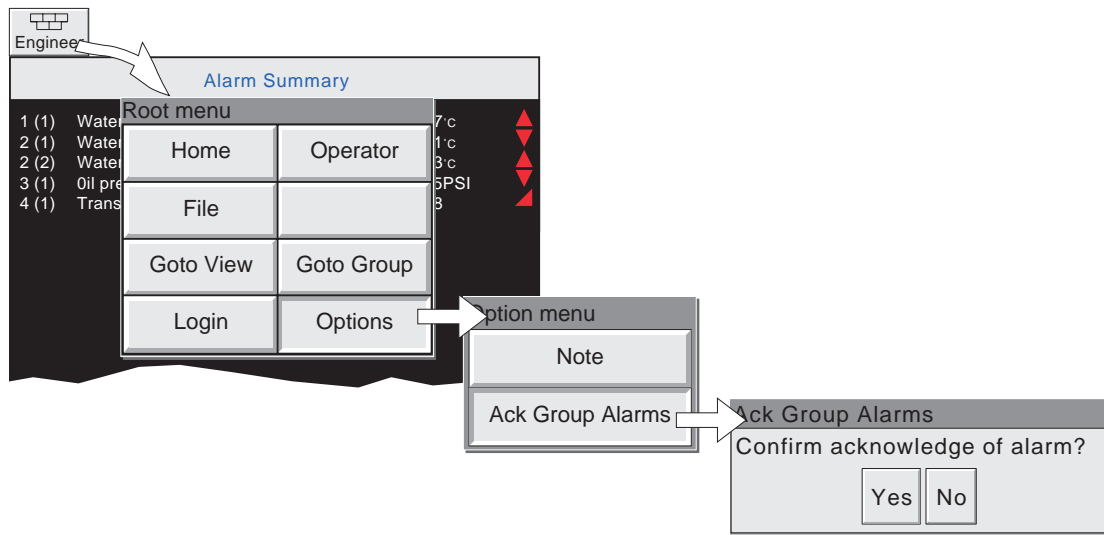

Figure 3.1.3b Group Alarm acknowledgement

3.1.3 ALARM INDICATORS (Cont.)

INSTRUMENT ALARMS



This indicator appears, flashing, if any of the following alarms are active. The Instrument alarm summary page, described above, allows the user to view any such alarms.

Archive failed -(message)	Message explains archive failure - due to disk being missing, write protected, faulty, full etc.
Battery-backed RAM cleared	This message appears if the battery has failed, and the unit has been switched off.
Channel failure	Indicates a hardware failure in the input channel circuit
Channel error	Indicates a hardware failure in the channel circuit or in the internal CJ temperature measurement
Clock failure	Internal clock was corrupt at power up, or the time has never been set. Can be caused by battery failure, in which case the battery icon will also be visible. The error is cleared by setting the time and date. Server time forced to 00:00 1/1/1900.
Floppy disk worn	Appears if a number of attempts had to be made before write to the disk was successful. No data is lost, but the disk should be replaced as soon as is practicable.
Floppy disk corrupt	This appears if all attempts to write to the disk fail. In such a case, some data may be lost. If the damaged area of the disk is in the system part of the disk, it might appear to the recorder that it is unformatted, and the disk icon will disappear. The disk should be replaced immediately.
FTP Primary Server Failure	This error is set if the recorder fails, after two attempts, to establish communications with the primary server as defined in Archive Configuration (section 4.3.5). After the second attempt has failed, the Secondary server is tried.
FTP Secondary Server Failure	This error is set if the recorder fails, after two attempts, to establish communications with the secondary server as defined in Archive Configuration (section 4.3.5). See also 'FTP Primary Server Failure, above.
Insufficient non-volatile memory...	There is insufficient memory available for the configuration. Sometimes caused by the use of the Rolling Average maths function.
Internal flash: \user\ required repair	Error found (in the internal file system) at power-up, and corrected.
Internal flash: \system\ required repair	Error found (in the internal file system) at power-up, and corrected.
Internal flash: \history\ required repair	Error found (in the internal file system) at power-up, and corrected.
Maths Channel failure	Appears, for example, if the divisor of a divide function passes through zero.
Network boot failure	The recorder is unable to establish connection with the bootP server. This might be caused by, for example, cable failure, network hardware failure, etc.
Recording failure - (message)	Message explains recording failure e.g. file error, internal overflow etc.
Removable media failure	This error is set if the disk is corrupt, wrongly formatted etc. Becomes active only when an Archive is attempted.
Removable media full	Floppy disk or PC card full. Becomes active only when an Archive is in progress.
SNTP server failure	This alarm is set if:- a) the year received from the server is < 2001 or > 2035 or b) the configured SNTP server cannot be accessed
Time synchronisation failure	Set if 5 or more 'Time change events' are caused by the SNTP server within 24 hrs. A 'Time change event' is defined as occurring whenever the recorder time is found to be more than 2 seconds different from the server time. The alarm does not appear until 24 hours after the first of the five-or-more Time Change events occurred.

3.1.3 ALARM INDICATORS (Cont.)

CHANNEL ALARM



This red 'bell' indicator appears if any channel is in alarm. The symbol is illuminated continuously if all alarms are acknowledged or flashes if any active alarm is unacknowledged. Refer to [ALARM ACKNOWLEDGEMENT](#), above, for details of how to acknowledge alarms.

Note: If a point is in alarm, but not enabled in either group, the point's alarm symbol will behave as described above, but the alarm will not appear in the Alarm Summary displays. Such channels can be acknowledged only by using Ack All Alarms as described in [section 3.1.2](#), above.

CHANGE BATTERY



This flashing indicator first appears when the battery voltage indicates that the battery is approaching the end of its useful life. The indicator continues to flash until the battery is replaced (Annex B, section B3.2). The indicator does not appear if the battery is not fitted.

3.1.4 Disk icon

This shows the free space available on the disk. The disk icon appears soon after a disk or data card is inserted. Only archiving activity is indicated; during archiving, the central area of the disk icon flashes green, regularly. No other disk activity is indicated.

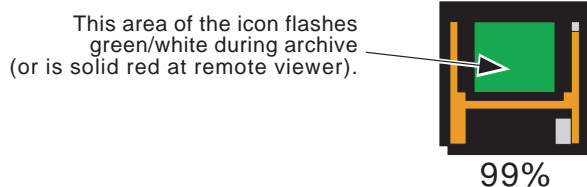

Figure 3.1.4 Archive activity indication

Note: When seen via Remote Viewer, the green flashing area of the disk appears as a solid red area during archive activity.

3.1.5 FTP Icon



For those recorders fitted with Ethernet option, the File Transfer Protocol (FTP) icon appears to the right of the disc icon position, whenever transfer activity is taking place.

3.1.6 Configuration Locked indicator



This symbol appears only when the Remote Viewer software is being used, in the following situations:

1. Whilst units are 'synchronising' configuration changes
2. Whilst configuration is taking place. If the reconfiguration is taking place at the host pc, then the symbol appears at the target instrument, and *vice-versa*.

3.2 NAVIGATION KEYS

These keys allow the user to perform various context-related tasks such as to access the [recorder configuration](#), to [archive data](#) etc. In addition to this, left and right arrow keys or open/close folder keys appear where relevant.

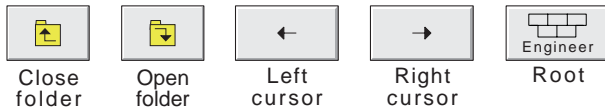

3.2.1 Key functions

Close folder	Used, where appropriate, to recall the previous (higher level) display page.
Open folder	Used, where appropriate, to call a further (lower level) display page.
Left cursor	Used to navigate backwards through a text string, when editing.
Right cursor	Used to navigate forwards through a text string, when editing.
Root	Calls the 'Root Menu' as shown.

ROOT MENU KEYS

Home	Causes a return to the 'Home' page from any page in the recorder. As delivered, the 'Home' page is the vertical trend display as depicted in figure 3, but this can be edited (in Operator/Config - Views) to be any of the available display modes - Horizontal trend, Vertical bargraph, Horizontal bargraph, Numeric etc.
Operator	Causes the top level Operator page to appear. The appearance of this display is dictated by the security level that the recorder is set to, and by the access level of the user. As despatched from the factory, the recorder is in 'logged out' mode and the Operator page contains only the buttons labelled 'Archive', 'Security' and System. Further details appear in ' Access to configuration ' below.
File	Allows the file system in that area of Flash memory that is accessible to the user, and the file system on any floppy disk fitted to be viewed. See section 5 for details.
Goto View	Allows the user to select the display mode for the current group, as shown in figure 3.2.1, below. Display modes not enabled for this group in Config/Views configuration pages do not appear. Goto View also offers an alternative means of entry to the Alarm Summary page described in section 3.1.3, and also allows entry to the current group's Message Log pages, described below.
Goto Group	Allows group 1 or group 2 (if fitted) to be selected for display. If group 2 is not fitted, the Goto Group menu does not appear. If either group is not ' display enabled ' in the Config/Views page (section 4.3.4) it is greyed. An alarm icon appears on the relevant group key if it containing one or more points in alarm. The icon flashes if any of the group's alarms have not been acknowledged.
Login	Calls the login page described in section 3.3.1 , below
Options	Used for a number of functions depending on the context. For example, entering or exiting Trend History mode, or calling the filer option pop-up.

To quit the Root menu, touch the root key again.

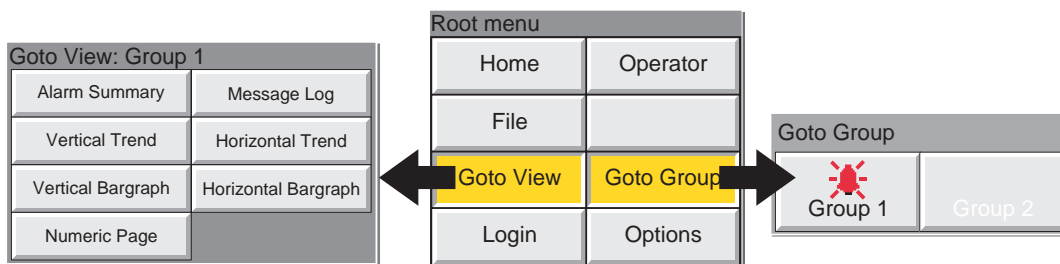

Figure 3.2.1 Root key menu and Goto View and Goto Group menus

3.2.1 KEY FUNCTIONS (Cont.)

MESSAGE LOG

The Root menu/Goto View/Message log key calls the first Message Log page for the current group to the screen, as shown in figure 3.2.1c, below. Alternatively, Message Log can be selected from the Alarm & Message options menu, (section 3.1.3) and in this case, if there are multiple groups, the user selects a 'Group' for the Message Log display from a pop-up (Goto Group) menu.

If there are more messages than can be displayed in the height of the screen, a scroll bar appears to allow 'hidden' messages to be displayed.

Messages are retrieved from the history files in batches of 100 messages. If there are more than 100 messages, 'Earlier messages..' appears after the hundredth message. Touching 'Earlier messages..' calls the option menu, and touching 'Earlier messages..' in this menu, calls the next batch of 100, and so on. If applicable, operating 'Later messages..' / 'Later messages..' calls the previously displayed 100 messages.

As can be seen from the figure, the list of messages can be 'filtered' both by type and by time. For example, setting the message type to 'Alarm' and the period filter to 'Last Day' excludes all messages except alarm messages which have occurred within the previous 24 hours.

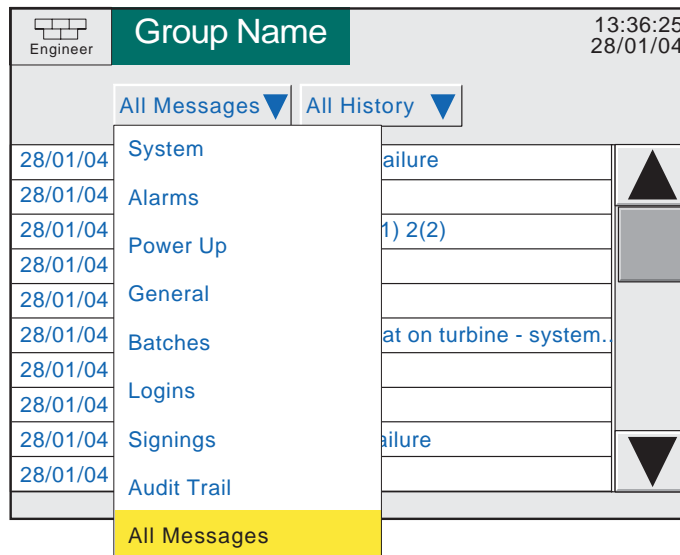

Figure 3.2.1c Message log page showing message-type picklist

MESSAGE TYPE FILTER

All Messages	All messages are displayed
System	Only system messages and instrument alarms are listed.
Alarms	Only alarm on/off and acknowledgement messages appear.
Power Up	Displays power up messages only including Config revision and Security revision are included. See section 4.6.5 for more details.
General	Displays messages sent via Modbus, and operator notes/custom messages etc. If the e-mail option is fitted, a message is generated each time an e-mail is sent. See section 11 of the options manual for details of the e-mail option.
Batches	Not supported by this recorder version
Logins	Not supported by this recorder version
Signings	Not supported by this recorder version
Audit trail	Not supported by this recorder version

3.2.1 KEY FUNCTIONS (Cont.)

PERIOD FILTER

This picklist allows the user to select one of the following to define the period of time that the message list is to encompass:

All History, Last Month (28 days), Last Week, Last 3 Days, Last Day or Last Hour,

OPTION MENU

Touching a message (highlights yellow) calls the Option Menu* as shown in figure 3.2.1d, below.

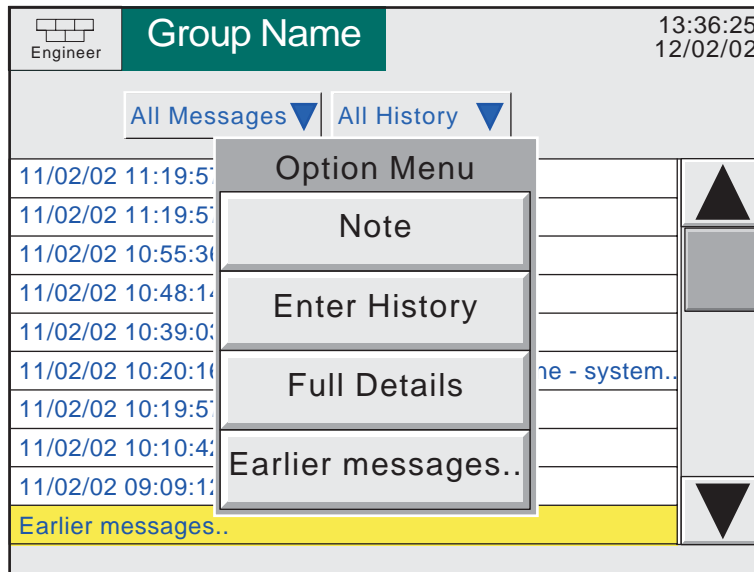

Figure 3.2.1d Message Log options menu

Note

See [section 3.5](#) of this manual

Enter history

Operating the Enter History key causes the recorder to display that page of history which includes the highlighted message. See [section 3.4.1](#) for details of trend history. When in Trend history mode, operating the Message Log key calls that message log page which contains those messages which are nearest the trend history cursor time.

Full details

If the highlighted message is wider than the display, the whole message can be displayed by operating the 'Full Details' key.

Refresh/Earlier messages../Later messages..

'Refresh' places (at the top of the screen), any messages, which have occurred since the Message Log page was last entered, or since the last 'Refresh'. If earlier or later messages have been selected, then 'Refresh' is replaced by 'Earlier messages..' or 'Later messages..' as appropriate, and operating the key calls the next or previously displayed group of 100 messages to the display respectively.

* The option menu can also be called by touching the option key. In this case:

- Enter History calls the current Trend History display, as described in [section 3.4.1](#), and
- Because no message is highlighted, the 'Full Details' key is not enabled,

Notes:

- Selecting 'Enter History' whilst either 'Earlier Messages' or 'Later Messages' is highlighted calls the current History page.
- If the Option Menu has 'timed out' leaving a message highlighted, and the option key is operated, then this is equivalent to reselecting the message.

3.3 FIRST SWITCH-ON

When power is applied the recorder initialises, and once this process is complete, the home page is displayed. It is unlikely that this will contain any useful information because the input channels will not, as yet, have been configured to suit the type of input signals being applied to them, as described in [section 4](#).

Notes:

1. There is no on-off switch associated with the recorder
 2. Date, time and the message 'Power Up' are printed on the chart each time power is applied to the recorder, followed by date, time, Config Revision, Security Revision - see 'About' (section 4.6.5)
 3. A red line is drawn across the width of the chart at power up.
-

The recorder has four security levels as follows

Logged out	Initially, no access to recorder configuration is possible. Only Archive, Security/Login and the System 'About' functions can be accessed - via the root menu. Limited or full access can be permitted from 'Engineer' level.
Operator	No access to recorder configuration is possible until access permissions have been set up. Section 4.4.1 , describes how limited or full access can be permitted by an operator with 'Engineer' level access.
Engineer	Accessed initially, by entering '10' as the password (section 3.3.1 below). Full access to all recorder functions is available. Section 4.1.1 describes how the Engineer password can be edited and an Operator level password edited, if required. The section also describes how access permission to some or all of the recorder functions can be granted, or not, to individual user names and default security levels (except service).
Service	Full access to all recorder functions and to areas of recorder memory for diagnostic purposes. For use only by Service Engineers.

3.3.1 Access to Configuration

- 1 Once the recorder has initialised, touch the Root key, followed by 'Login'. Touching the 'Logged out' field in the resulting display, calls the access level picklist as shown in figure 3.3.1a.
- 2 Press 'Engineer' to call the Password request page.
- 3 Touching the blank Password area calls the keyboard display (see figure 3.3.1b).
- 4 Touch <Numeric><1><0><OK> to enter the password '10'. The screen reverts to the 'Home' page.
- 5 Operation of the [Root](#) key followed by a touch on the Operator key calls the top level page allowing access to the [Archive](#), [Save/Restore](#), [Config](#), [Security](#), [Network*](#), and [System](#) areas described in section 4 below.

*Network configuration appears only if the Ethernet option is fitted.

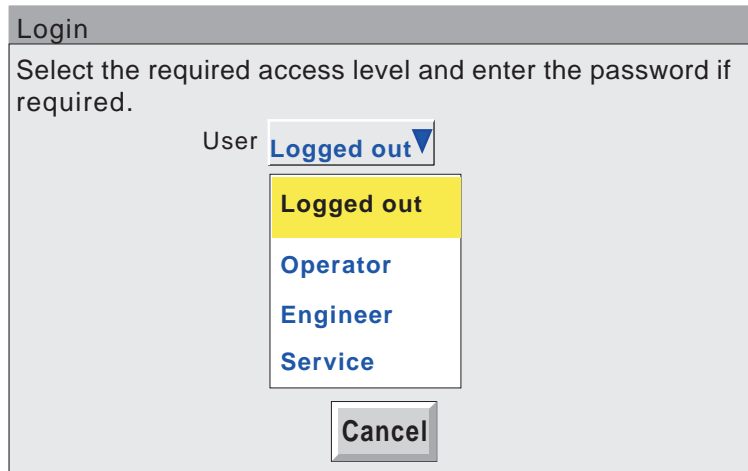

Figure 3.3.1a Access to configuration

Note: The figure above shows 'Login by user list'. If the Security Manager option is fitted, an alternative procedure (Login by user ID) is possible. See [section 4.4.2](#) (Management) for details.

3.3.1 ACCESS TO CONFIGURATION (Cont.)

TEXT STRING ENTRY

The keyboard which appears when the password area is touched is the same as that which appears when any non-numeric text string entry is required (e.g. channel descriptor). Figures 3.3.1b and 3.3.1c below are an attempt, within the limitations of the illustrating process, to depict the available keyboards and thus the available character set. Actual entry of the text string is by touching the relevant key. For items which require only a numeric entry (e.g. channel range) the numeric keyboard appears.

When editing existing text strings, the existing text string appears highlighted, and will be replaced in its entirety by the first character entered. To avoid this, the left arrow key can be touched to 'unhighlight' it.

Immediately below the keyboard are six keys with the functions listed below. When active, the background colour changes to yellow for as long as the key is active.

- Shift* Once the shift key has been pressed, the next-entered letter appears as a capital; subsequent letters are in lower case.
- Caps* When pressed, all subsequent letters appear as capital letters until the Caps key is operated again
- BSpC This backspace key deletes character to the left of the cursor.
- Ovr If selected, the next-entered character replaces (overwrites) the existing character to the right of the cursor position. If not selected, the next-entered character is inserted into the existing text string at the cursor position.
- Ok Used to save the new text string and to return to the page from which the keyboard was called.
- Cancel Causes a return to the page from which the keyboard was called without saving the new string.

**Note: The character on each display key is always a capital letter, whether or not the actual character being entered is in capitals or lower case.*

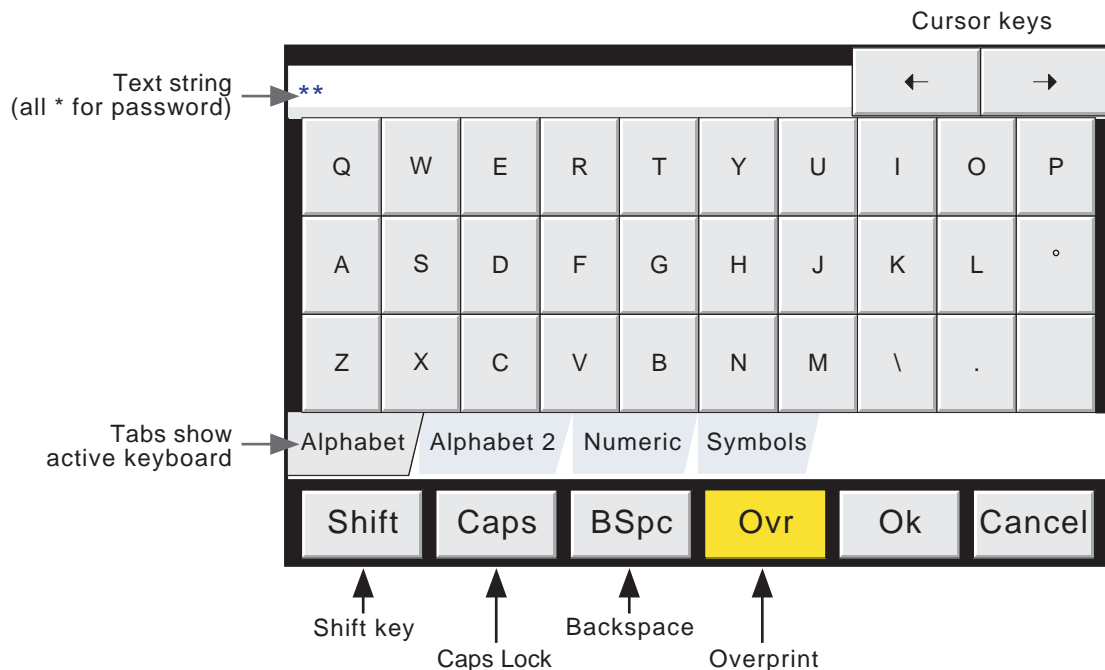
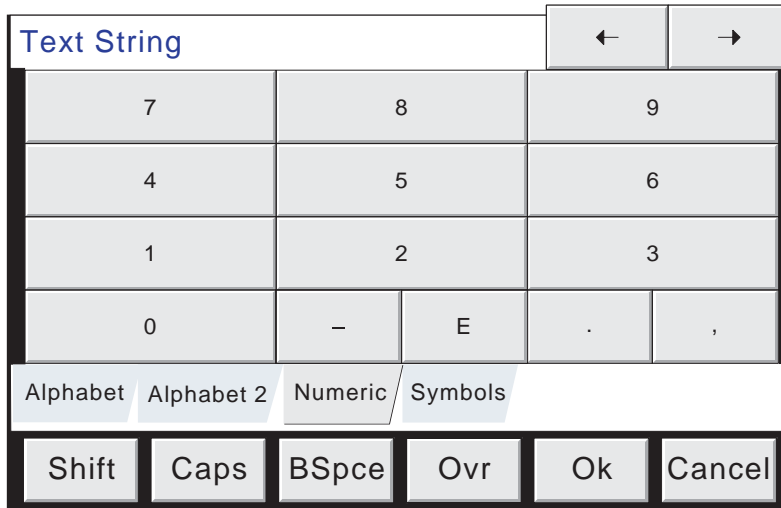

Figure 3.3.1b Alphabet 1 keyboard

3.3.1 ACCESS TO CONFIGURATION (Cont.)

TEXT STRING ENTRY (Cont.)



The 'E' key is used when entering exponents

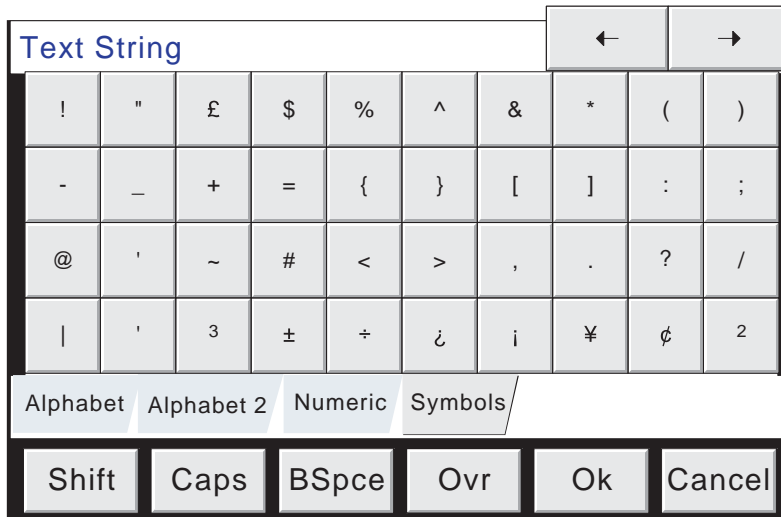

Figure 3.3.1c Alternative keyboards

3.4 DISPLAY MODES

The display modes described below allow process values (input channels, totalisers etc. - known collectively as points) for the current group to be displayed as vertical or horizontal 'chart' traces (Trend modes), as bargraphs (vertical or horizontal) or as numeric values. The display mode associated with the home page is Group 1, Vertical Trend when dispatched, but any of the other display modes can be selected as the home page in [Configuration/Views](#) - section 4.3.4. The current display mode can be changed using the [Root menu\Goto View](#) key. The [Home](#) key returns the user to the Home page from anywhere in the Operator or Configuration pages in the recorder.

3.4.1 Vertical Trend display

This (default) display ([figure 3.4.1b](#)) shows each point in the display group as though it were being traced on a white chart. (It is possible to display on a black 'chart' instead, by selecting Dark Trend Background in [Configuration/Views](#)). In either case, some thought should be given to trace colours selected in channel configuration. When selected, dark background applies both to vertical and horizontal trend display modes for both Groups.

One of the channels is said to be the 'current' or 'scale' channel. This channel is identified by its diamond shaped pen icon and by its descriptor, digital value and scale being displayed on a 'current-channel faceplate' across the full width of the chart. Faceplates for all the group channels can be displayed, by using the Faceplates On/Off key in the option menu. If selected On, faceplates (showing colour, descriptor, digital value and units) for all the group's channels appear either above the current channel's faceplate (one or two points in group) or at the right hand edge of the screen (three or more points in the group). If there are more than six points in the group, a scroll bar also appears allowing hidden faceplates to be viewed.

Each channel in the display group becomes the 'current' channel, in turn, for approximately 10 seconds – i.e. the channels are cycled-through, starting with the lowest numbered channel. Once the final channel in the group has been displayed for 10 seconds, the lowest numbered channel is returned to and the sequence repeats. This scrolling process can be stopped using the Channel Cycling key in the Option menu.

To select a particular channel to be the current channel, the relevant pen icon can be touched. To cycle through the channels manually, the faceplate area is touched repeatedly until the required channel is reached.

If a channel is included in the display group but its status is 'not good' for some reason, then its pen icon is hollow.

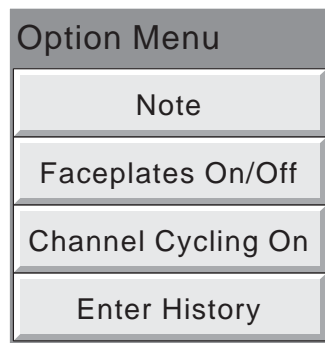

Figure 3.4.1a Option menu

3.4.1 VERTICAL TREND DISPLAY (Cont.)

TIME CHANGE RECORDS

For vertical trend mode only, a line is drawn across the width of the chart whenever a time discontinuity in the record occurs. These lines are volatile in real-time i.e. they disappear if the display mode is changed, or if a configuration page is called etc.

- Red line A red line is drawn on the trend history chart at power up.
- Blue line A blue line indicates that recording has been disable/enabled in Group Configuration (section 4.3.2), or by a recording job (section 4.7.9).
- Green line A green line appears if there has been a time change as a result of a clock job (section 4.7.6), an SNTP synchronisation or by the operator physically changing the recorder time.

Note: Changes from standard time to daylight saving time and back again are not 'green lined' in this way

TREND HISTORY

Trend history, allows the user to view the history of the display group. The maximum amount that can be recalled depends on a number of factors, including how many points are configured, how rapidly the traces are changing and so on. At a recording rate of 20mm/hour (see [group configuration - section 4.3.2](#)), with all channels configured, a minimum of 30 day's worth of traces is available for viewing, provided that the group contents are not re-configured during this period (in which case, the history starts at the end of the re-configuration). The amount of trace visible on the screen depends on the recording rate - the higher the rate, the less trace is visible at any one time.

Notes

- 1 Trend history is not available for groups with 'Recording Enable' disabled (Group configuration - section 4.3.2).
 - 2 Channel cycling is inhibited in Trend History Mode. To increment the current channel, touch the faceplate.
 - 3 Group faceplates are not displayed in History Mode.
 4. With A/B switching selected, traces are displayed with the 'A' or 'B' span/zone, colour settings etc. obtaining at the cursor time. See sections 4.3.2, 4.3.3 and 4.7 for more details of A/B switching.
-

To enter Trend History, the Root Menu Options key can be used (as shown in figure 3.4.1), or the trace area of the screen can be continuously touched until the screen blanks prior to re-drawing. A 'Preparing History, please wait' message appears whilst the re-drawing calculation is taking place. Although tracing stops whilst trend history mode is active, no data is lost - Process Variable values are still saved in the recorder memory and alarms are still scanned-for and any associated action taken.

The History display is similar to the real-time trend display, with the addition of a slider control and up and down keys for selecting that part of trend history which is to be displayed. The controls are used as follows:

- 1 Touching the up/down key causes the record to move an incremental amount.
- 2 Holding the up/down key continuously, causes continuous movement.
- 3 Touching the bar above or below the slider causes a page-height shift.
- 4 Touching and dragging the slider, whilst observing the time/date display, allows the user to select the section of history exactly.

On first entry to the History mode, the channel value and the time and date shown in the faceplate are those at the top edge of the chart. Touching the screen causes a cursor to appear at point of screen contact. This cursor can be touched and dragged up and down the screen to provide a reference point on the current trace. The displayed value date and time refer to the cursor intersection with the current channel. To return to real-time trending, the Options key in the root menu is operated, followed by 'Exit History'.

3.4 DISPLAY MODES (Cont.)

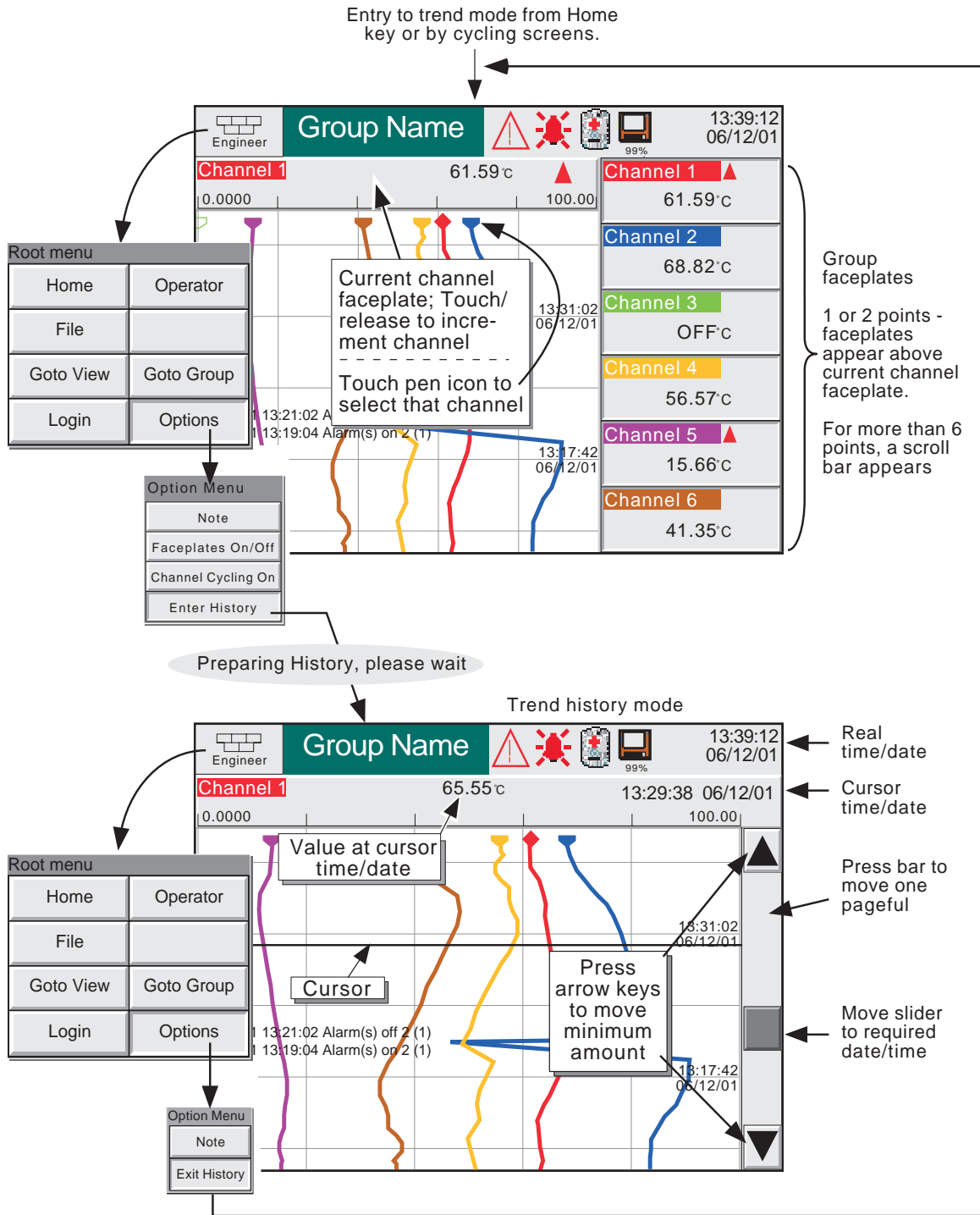

Figure 3.4.1b Typical Vertical Trend display (faceplates enabled) and trend history mode display

3.4 DISPLAY MODES (Cont.)

3.4.2 Horizontal Trend display

This display (figure 3.4.2a) is similar to the Vertical Trend display described above, except that the traces are produced horizontally rather than vertically.

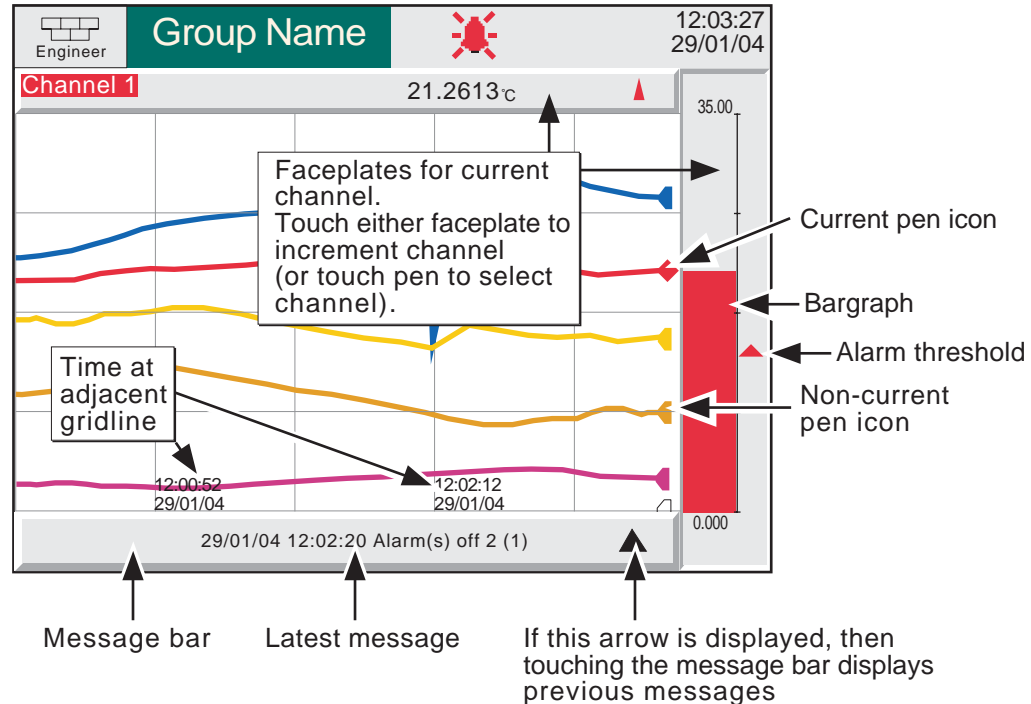

Figure 3.4.2a Horizontal trend display mode

One of the channels is said to be the 'current' or 'scale' channel. This channel is identified by its pen icon being diamond shaped rather than triangular as for non-current channels. If a channel is included in the display group but its status is 'not good' for some reason, then its pen icon is hollow. Each channel in the display group becomes the 'current' channel, in turn, for approximately 10 seconds – i.e. the channels are cycled-through, starting with the lowest numbered channel. Once the final channel in the group has been displayed for 10 seconds, the lowest numbered channel is returned to and the sequence repeats. This scrolling process can be stopped using the Channel Cycling key in the Option menu.

As well as the normal faceplate above the 'chart', showing the current channel's descriptor and its digital value, a bargraph representation of the current channel's value together with a scale showing the low and high range values for the channel appears to the right of the chart. Touching the faceplate or the bargraph* causes the current channel number to increment. To select a particular channel to be the current channel, the relevant pen icon can be touched. In either case, the bargraph and the background colour of the channel descriptor takes the colour of the current channel.

Time and date are printed on the 'chart' immediately to the right of alternate vertical grid lines, and it is these grid lines to which the printed time relates.

There is no horizontal trace Trend History function - touching the 'chart' for a few seconds (or using the Root menu Options key, then 'Enter History') calls the vertical trend history page described in section 3.4.1, above.

*Note: For 'zoned' points (section 4.3.3), the bargraph must be touched within the scale area to increment the channel.

3.4.2 HORIZONTAL TREND MODE (Cont.)

Below the 'chart', is a message bar, containing the latest message. If there is more than one message, an arrow head icon appears near the right hand end of this message bar, and if this appears, then touching the message bar calls a pop-up box (figure 3.4.2b) in which all relevant messages are displayed.

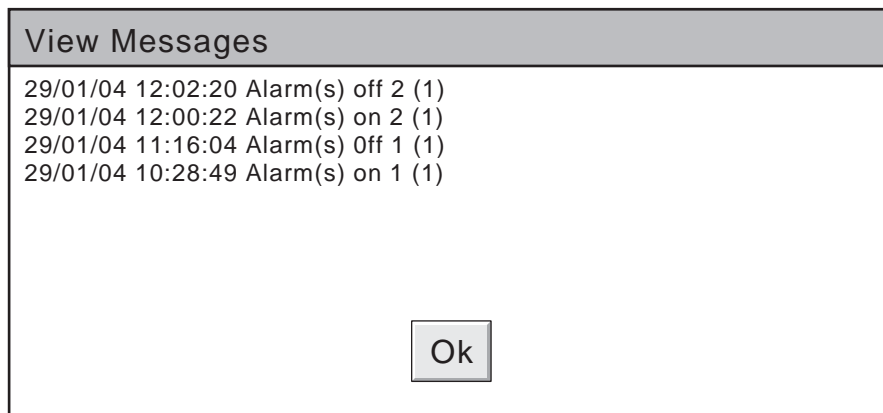

Figure 3.4.2b Horizontal trend mode message dialogue box

3.4 DISPLAY MODES (Cont.)

3.4.3 Vertical bargraph

This display mode shows the Process Variable (PV) values as vertical bars. Faceplates containing digital values and alarm data appear above the bars for one or two points, or at the right hand side of the screen (as shown below) for three or more points. Faceplates can be switched on and off from the Root menu/Options menu display.

Trend History mode is not available from this display mode.

Operation of the Root menu Options key calls the Option menu display for this display page, allowing faceplates to be selected on or off. This feature is available for vertical trend and vertical bargraph displays only.

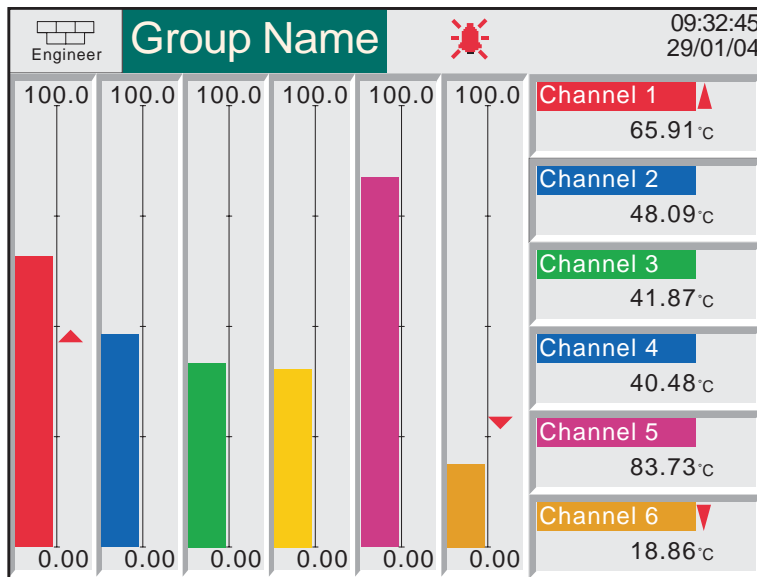

Figure 3.4.3a Vertical bargraph display (with faceplates)

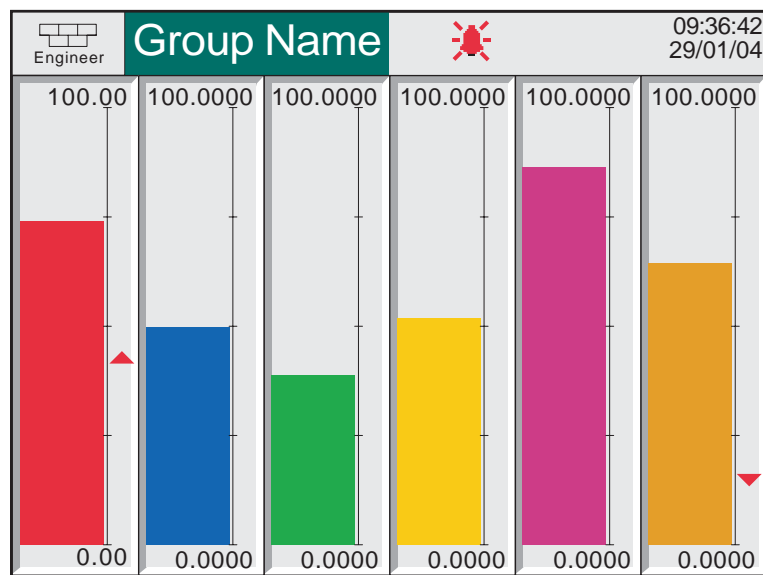

Figure 3.4.3b Vertical bargraph display (faceplates off)

3.4.4 Horizontal bargraph

This display mode shows the Process Variable (PV) values as horizontal bars with digital values and alarm data displayed, as shown in figure 3.4.4. Trend History mode is not available from this display mode.

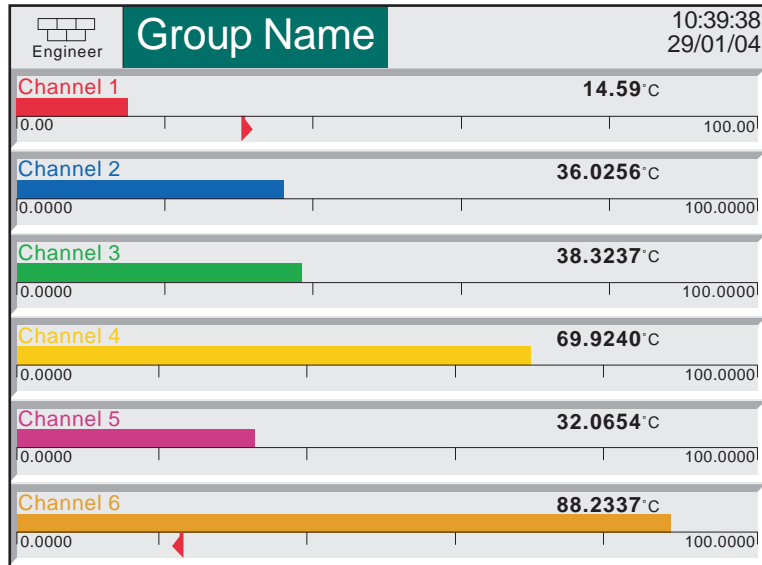

Figure 3.4.4 Horizontal bargraph display

3.4 DISPLAY MODES (Cont.)

3.4.5 Numeric

Numeric display mode shows the Process Variable (PV) values as digital values. The format (which is automatically selected) is based on the number of channels in the display group. Figures 3.4.5a and 3.4.5b, show typical examples of the one column (up to four channels) and two column versions (five or six channels) of this display mode, respectively. Within each version, the process variable display areas expand or contract to fill the screen. Trend History mode is not available from this display mode.

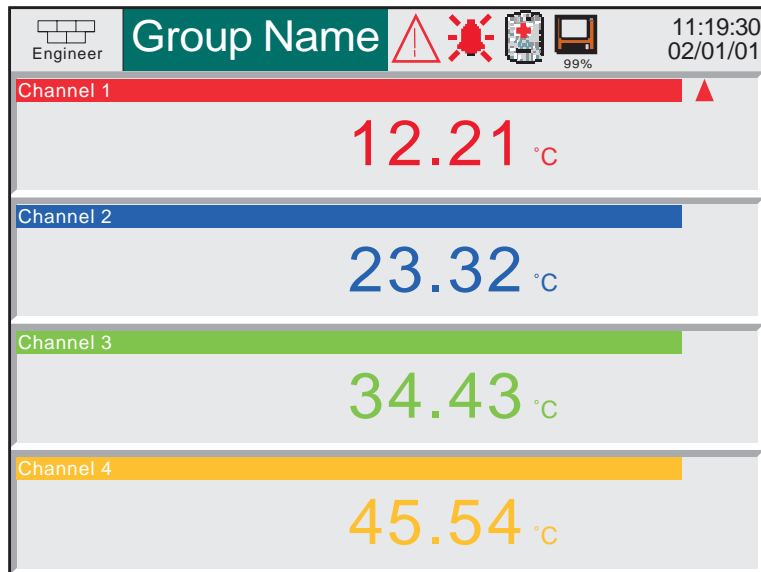

Figure 3.4.5a Numeric display mode (1 to 4 channels)

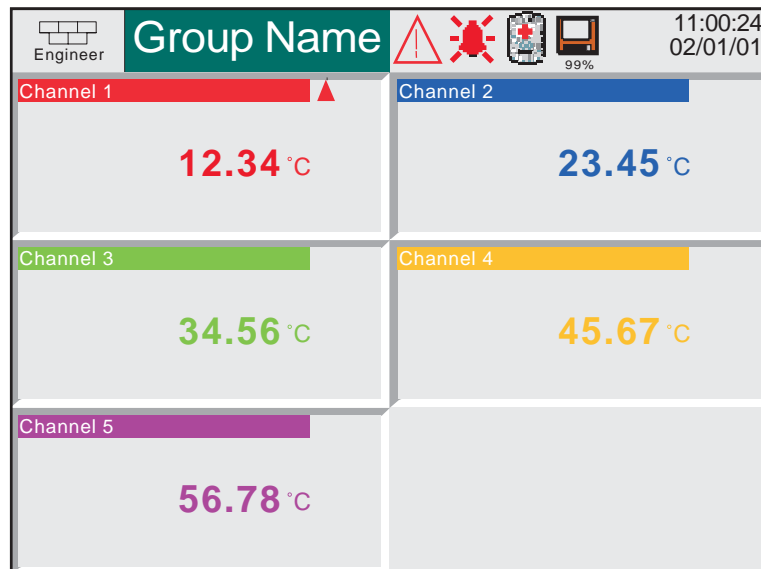

Figure 3.4.5b Numeric display mode (5 or 6 channels)

3.5 OPERATOR NOTES

It is possible for the user to enter a note, of up to 60 characters, from any display page. Each note is associated with the current display group and becomes a part of that group's history. The notes appear on vertical and horizontal trend displays only, although they can be entered in any display mode (but not during configuration).

The note appears on the chart, preceded by the date, time and current login name e.g.

12/09/01 10:32:43 Frederick Bloggs, New Spray nozzles fitted to Line A, Tube 1.

Date and time
Full User Name
Message

To enter a note:

1. Press the Root menu Option key, then the 'Note' key
2. Touch the Operator Note area of the resulting pop-up display.
3. Enter the required string of up to 60 characters (spaces are also counted as characters) using the pop-up keyboard display. Press Ok when finished.
4. View the message and
 - a press the Ok button to enter the note OR
 - b re-touch the text area to edit the note OR
 - c press the Cancel key to quit note entry.

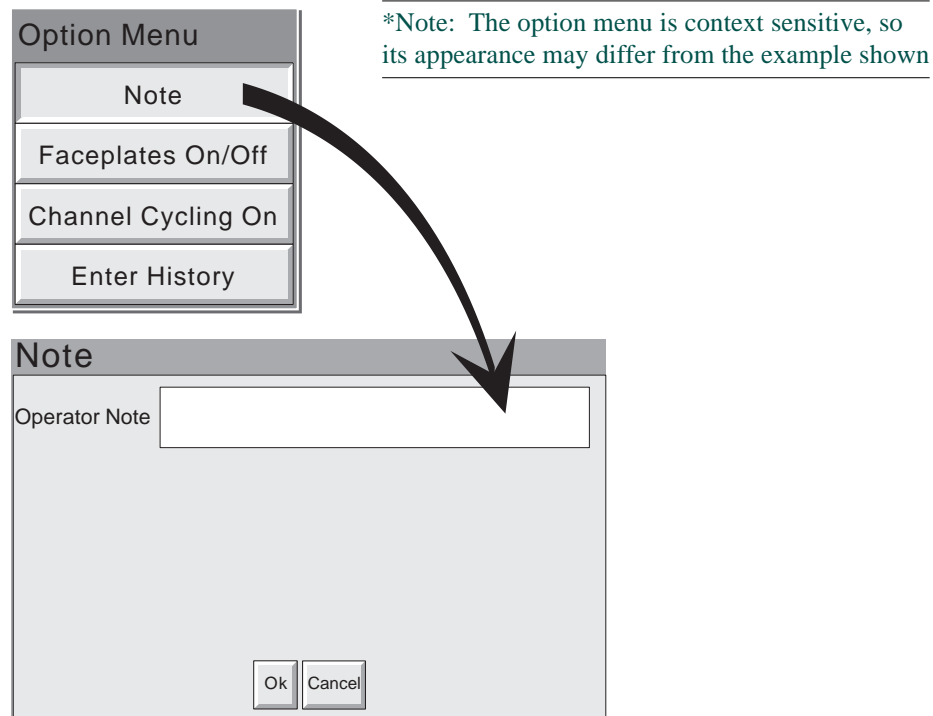

Figure 3.5 Access to note entry page

Note: Operator Notes should not be confused with similar messages, appearing as the result of a 'Job' action. Such messages are described in [Section 4.3.7](#) of this manual.

4 SETTING UP THE RECORDER

As described in the '[Access to Configuration](#)' (section 3.3.1) above, the setting-up of the recorder is divided into the following areas:

- Archive** Section 4.1 - Allows manual archiving of data [to disk](#) or (if the Ethernet option is fitted) to a remote host ([FTP transfer](#)).
 - Save/restore** Section 4.2 - Allows new configurations to be created and saved, and saved configurations to be 're-stored'.
 - Config** Section 4.3 - This is the major channel/alarm/option etc. area of configuration.
 - Security** Section 4.4 - Allows passwords to be entered and edited and allows the Engineer-level password holder to enable/disable areas of configuration to Operator-level password holders. New users can be added, with their own user names, passwords and access level permissions.
 - Network** Section 4.5 - This area sets up the IP address/host names etc. used in FTP transfer, Remote Viewer and SNMP applications (if the Ethernet option is fitted).
 - System** Section 4.6 - Allows:
 - Time and date functions to be set and edited (including daylight saving start and finish dates, time zones etc.)
 - Display language to be chosen
 - Option key codes to be entered
 - Inputs to be adjusted.
 - System contains an 'About' screen describing the software/hardware status of the recorder.
- [Section 4.7](#) describes the various job categories available to the user

Note: In all the following descriptions, if a change is made to a menu item, then the item text changes from black to red, until it is 'saved'.

4.1 ARCHIVE

Note: The archiving functions described below can also be initiated by job action - see section 4.7.12

4.1.1 Archive to disk

This allows the user to initiate data transfer, to a mass storage medium such as a floppy disk, for all groups with 'Archive to Media' enabled ([Group configuration - section 4.3.2](#)), by touching the relevant archive period key (e.g. Last Day').

Archiving starts as soon as the selection is made, and cannot be stopped until completed, unless the Cancel Archive key is operated, in which case the archive will be stopped after a confirmatory message has been responded to. The Cancel key is active only if 'Archiving Control' is enabled in Security/Access ([section 4.4](#) of this manual). If archiving is enabled for more than one group, a warning message appears.

Selection of 'Bring Archive Up To Date' causes the recorder to select whichever of the Last Hour/Last Day etc. categories is appropriate to bring the archive up to date. Figure 4.4.1 shows the archive to disk menu.

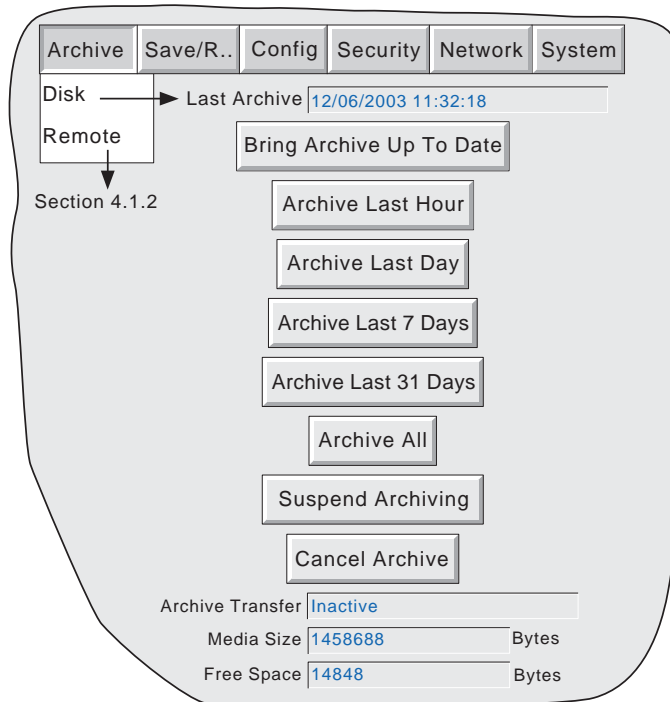

Figure 4.1.1 Disk archive strategy configuration

If the disk becomes full before archiving is complete, archiving pauses and a pop-up request appears, asking for the disk to be replaced. If this request is not responded-to within 10 minutes of its appearance, archiving is aborted,

Unattended archiving can be paused by the user (e.g. to change disks without losing data) by operating the 'Suspend Archiving' / 'Resume Archiving' button. Any archiving in progress is allowed to complete before the 'Suspend Archiving' request takes effect. Transfer activity is indicated in the 'Archive transfer' window. Should the disk become full, the user will be prompted to replace it with a different one.

Below the selection buttons are a number of status windows relating to the mass storage medium.

If automatic archiving is active ([section 4.3.5](#)), then this and the manual archive will operate on a first come-first served basis. Some files will be saved twice in such a circumstance, the later archive's files overwriting any earlier archive's files which have the same name.

4.1.2 Remote archiving (FTP transfer)

This allows archiving of recorder files, for all groups with 'Archive via FTP' enabled, to a remote computer, connected (using the RJ45 telephone type connector at the rear of the recorder) either directly, or via a network. 'Archive via FTP' is enabled/disabled as part of ([Group configuration - section 4.3.2](#))

In order to carry out a successful transfer, details of the remote host must be entered in the Archive section of the 'Config' menu ([section 4.3.5](#)).

Note: An FTP server must be running on the remote host.

Figure 4.1.2 shows the archive menu for remote archiving. The Archive last hour/day etc. keys allow the user to determine which files are to be archived. Selection of 'Bring Archive Up To Date' causes the recorder to select whichever of the Last Hour/Last Day etc. categories is appropriate in order to bring the archive up to date. The 'Last Archive' window shows the time and date of the previous archive. The Archive Transfer window shows archive status as 'Active' or 'Inactive'.

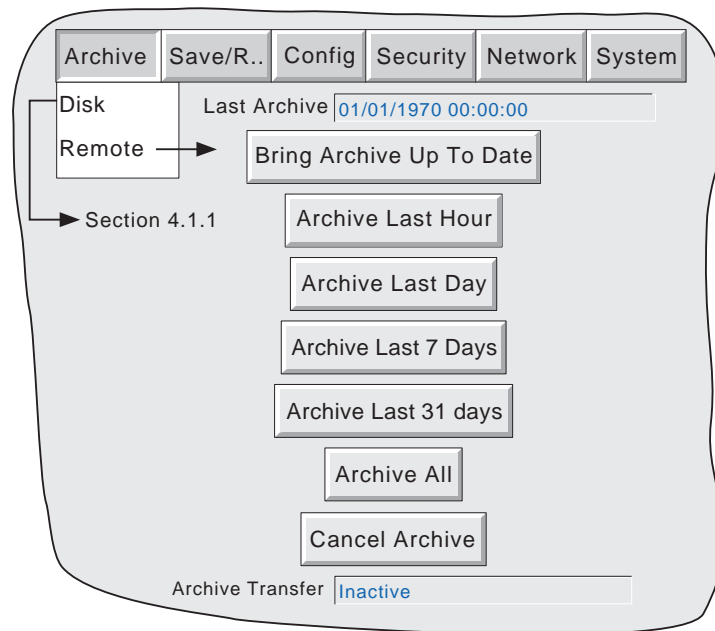

Figure 4.1.2 Remote archive strategy configuration

Additionally, a user on a remote PC has full viewing capabilities, can extract recorder files at any time, and can access those items of recorder configuration that are associated with the user's login. For successful connection, 'Connect from Remote' must be enabled and the 'Remote user name' and 'Remote password' must be defined in one of the accounts (all in the Security access menu ([section 4.4.1](#))).

Notes:

1. In order to view history files when accessing the instrument remotely, the recorder's address, the 'Remote user name' and the 'Remote password' must be supplied to an FTP client such as PC Review or Microsoft® Internet Explorer.
2. When accessing files using Microsoft® Internet Explorer, the address (URL) field can be in one of two forms:
 - a ftp://<instrument IP address>. This allows the user to log in as the anonymous user (if the instrument has any account with 'Remote user name' set to 'Anonymous' and a blank password).
 - b ftp://<user name>:<password>@<instrument IP address> to log in as a specific user.
3. For IE5 users only: Microsoft® Internet Explorer displays, by default, history files only. To exit the history folder, either uncheck the Tools/Internet Options/Advanced/Browsing/"Enable folder view for FTP sites" option, or check the Tools/Internet Options/Advanced/Browsing/"Use Web based FTP" option.

4.2 SAVE / RESTORE

As shown in figure 4.2a, touching the Save/Restore key calls the picklist: Save, Restore, New, Text, Import/Export user Linearisation.

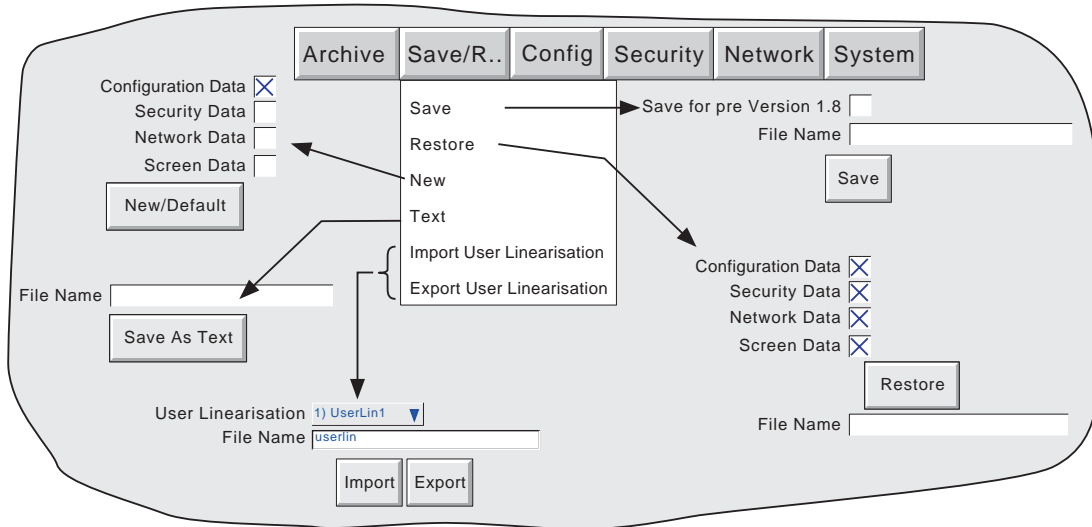

Figure 4.2a Save/Restore menu

Where a file name is required, then, if the displayed file name is suitable, operation of the 'Save', 'Restore', 'Import' or 'Export' key will initiate the action. If, instead, a file name has to be entered, this is carried out as follows:

Touching the file name window causes a pop-up menu to appear, giving a list of 'Volumes' in the Flash memory or on the floppy disk (if inserted). Figure 4.2b shows an imaginary Volume contents list, displayed by touching the name 'user', then operating the 'open folder' key. (See section 5, below for more details). Once the correct folder is open, either select an existing file, or enter a new file name, by touching the FileName window and entering the name using the pop-up keyboard(s) as described in section 3.3.1 above. Operation of the Save or Restore key initiates the action.

Name	Type	Date	Bytes
call\	Folder	03/06/00 12:35:08	
config\	Folder	01/05/00 10:27:13	
Filter1a	Config	05/07/00 10:22:23	4445
lib\	Folder	05/07/00 10:23:14	
sdb\	Folder	11/05/00 14:01:08	

FileName: Filter1b Save Cancel

Figure 4.2b Typical volume contents page

4.2.1 Save

Touching this item allows the current configuration to be saved in the recorder's memory. Files saved in this way are not in a 'readable' format and are used only for archive /security purposes or for transfer to another, similar, recorder.

SAVE FOR PRE VERSION 1.8

Checking this box, prior to saving a configuration, means that the configuration can successfully be loaded (Restored) into other recorders running software versions prior to 1.8. If the box is left unchecked, then Saved configurations can be Restored only to recorders running software versions 1.8 or higher. The message 'Unsupported File' appears if an attempt is made to save an 'Unchecked' configuration into a pre version 1.8 recorder. See [Section 4.6.5 \(About\)](#) for details of how to determine software version.

4.2.2 Restore

Touching this item allows the user to select or type-in a previously saved configuration file name, which will then be used as the current configuration. Touching the 'Restore' key completes the operation. Tick boxes allow one or more of Configuration Data, Security Data (note 3), Network Data or Screen Data to be chosen to be restored.

Notes

- 1 Screen data relates to faceplate status for vertical trend and vertical bargraph display modes.
 2. If archiving is in progress when a 'Restore' is requested, the Restore operation will be delayed until the archive is complete (maybe several minutes). If required, the 'Cancel Archive' key can be used to speed up the restore process, at the cost of losing the archive data.
 3. If 'Centralised Security' is active (part of Security Management configuration - [section 4.4.2](#)) 'Security Data' is not selectable (either for 'Restore' or 'New' (below)).
-

4.2.3 New

Touching this item causes the factory entered default configuration to be loaded for use, or for editing. Operation of the New/Default key completes the operation. Tick boxes allow one or more of Configuration Data, Security Data (note 3, above), Network Data or Screen Data to be chosen to be restored. (Screen Data relates to faceplate status for vertical trend and vertical bargraph display modes.)

4.2.4 Text

This is identical to the 'Save' function described above, but the configuration is saved in ASCII format, and can be transferred to a computer and read, printed etc. as required. It is not possible, using this means, to modify the configuration and then re-load it.

4.2.5 Import User Linearisation

The Import Linearisation feature allows linearisation tables to be imported either via the floppy disk, or if the Remote Viewer option is fitted, directly from the host PC.

Touching the User Linearisation field allows the user to select which of 'UserLin1' to 'UserLin4' is to contain the imported file.

Touching the File Name field, calls a popup menu similar to that shown in [figure 4.2b](#). This allows the user to select the table to be imported.

The file must be comma separated ASCII as follows:

```
n,  
X1,Y1  
X2,Y2  
X3,Y3  
.  
.  
Xn,Yn
```

where 'n' is the total number of XY pairs in the table, and for each pair, X is the input value, and Y is the linearised value corresponding to X.

See [section 4.3.8](#) for full details.

Note: Imported linearisation tables will not become effective until after the next configuration 'Apply' operation

4.2.6 Export User Linearisation

Similar to 'Import user Linearisation, above, the Export Linearisation feature allows linearisation tables created in the recorder to be exported either via the floppy disk, or if the Remote Viewer option is fitted, directly to the host PC.

See [section 4.3.8](#) for full details.

Note: If an exported linearisation table is to be used in a recorder with software version prior to version 2.2, it must be exported in Numeric format (i.e. not in Scientific format).

4.3 CONFIGURATION

Touching this key calls the top level configuration pick list: [Instrument](#), [Groups](#), [Channels](#), [Views](#), [Archive](#), [Events](#), [Messages](#), etc. as shown in the overview figure (figure 4.3).

When making changes to the configuration the name of each changed parameter is displayed in red (instead of the normal black) until the 'Apply/Discard' key has been operated. For example, in channel configuration, if a thermocouple were to be changed from Type J to Type K, 'Lin Type' would appear in red, until the Apply key was operated.

Should an attempt be made to leave configuration with unsaved changes, a warning message appears, allowing the user to apply the changes, to discard the changes or to return to configuration (Cancel).

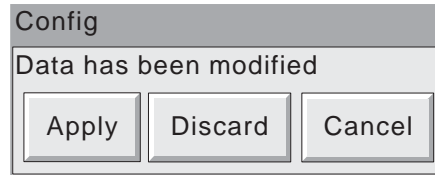

4.3 CONFIGURATION (Cont.)

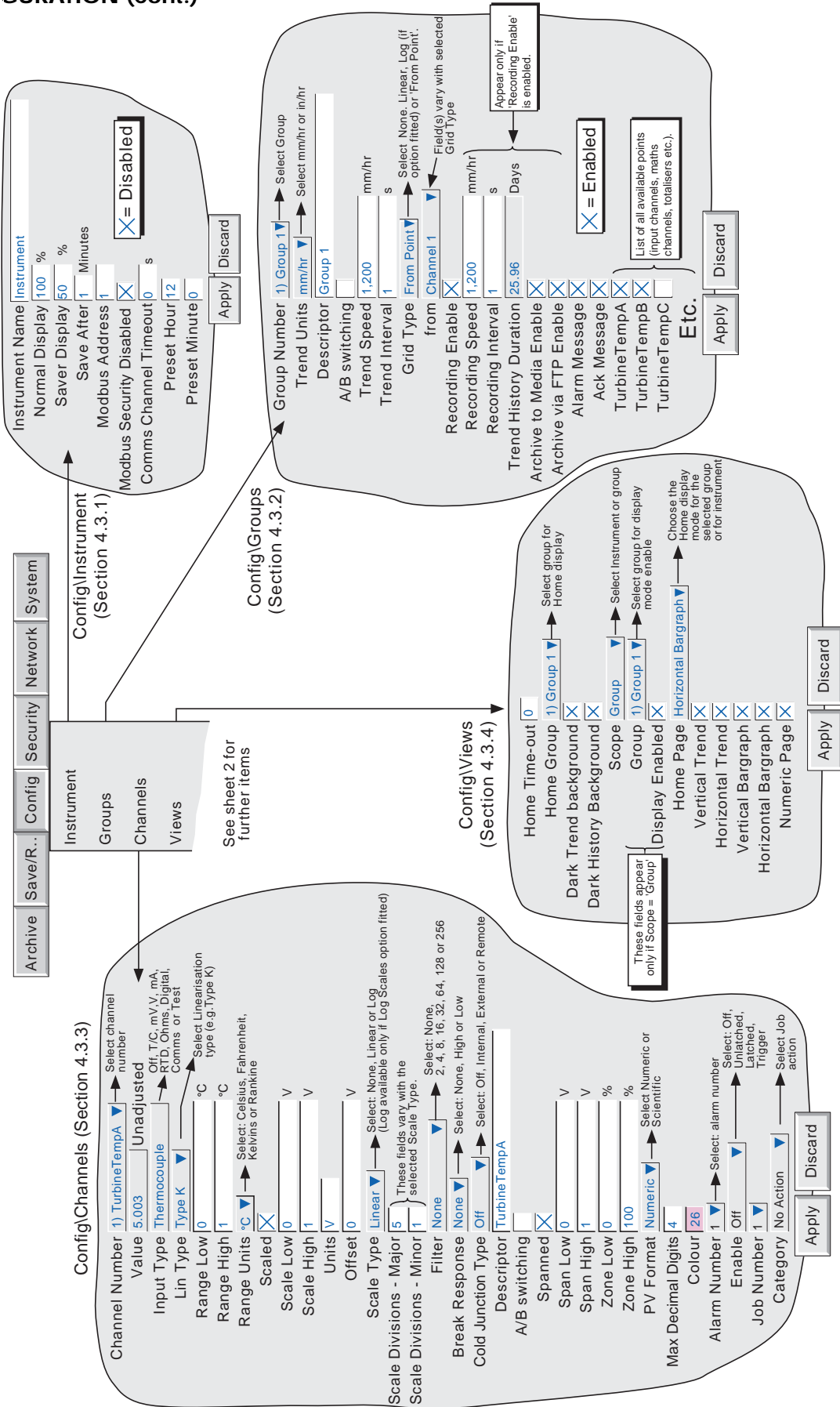

Figure 4.3 Configuration menu overview (sheet 1)

4.3 CONFIGURATION (Cont.)

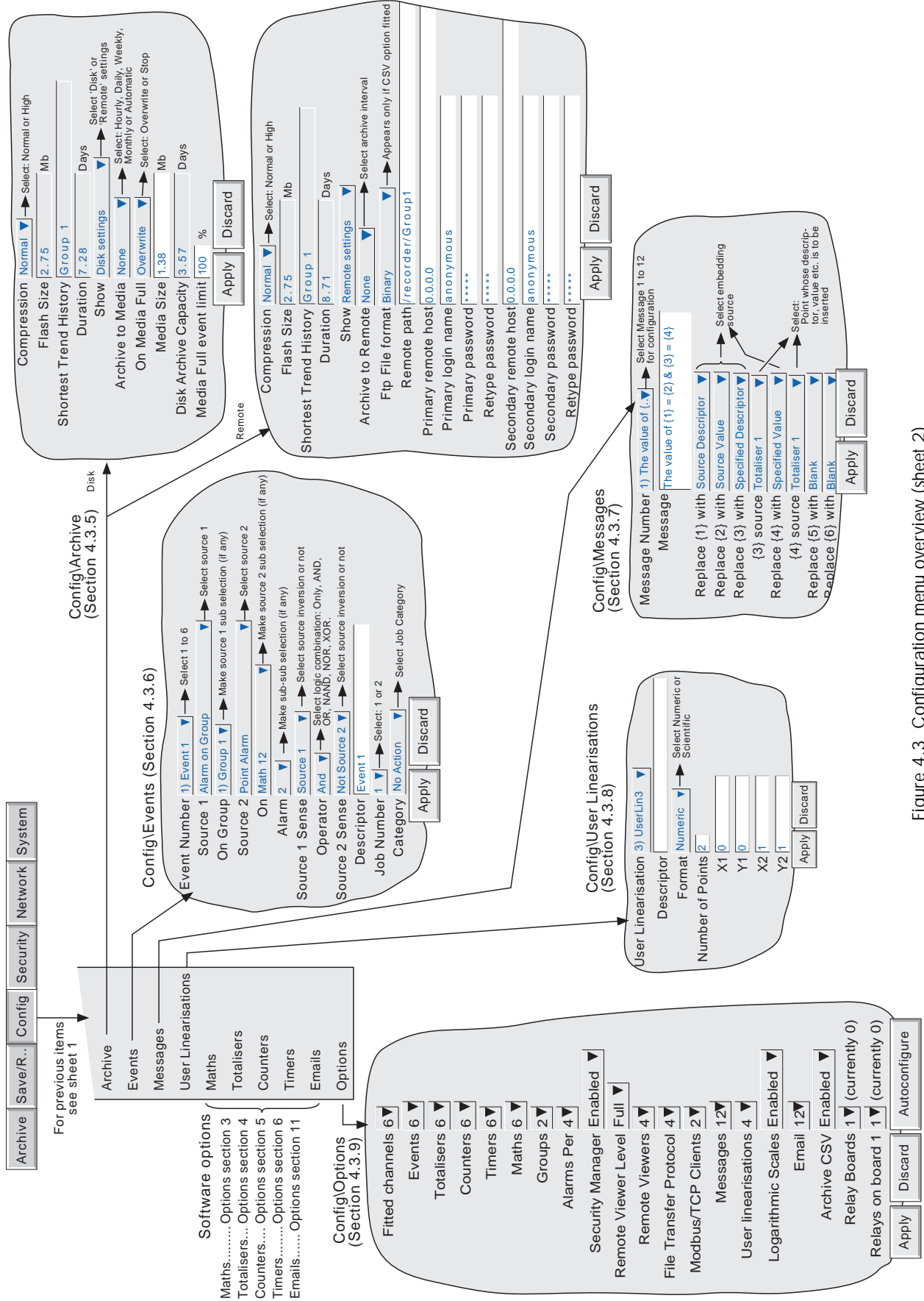

Figure 4.3 Configuration menu overview (sheet 2)

4.3.1 Instrument configuration

The screenshot shows the Instrument Configuration menu with the following settings:

- Instrument Name: Instrument
- Normal Display: 100 %
- Saver Display: 50 %
- Save After: 1 Minutes
- Modbus Address: 1
- Modbus Security Disabled: (Legend: X = Disabled)
- Comms Channel Timeout: 0 s
- Preset Hour: 12
- Preset Minute: 0

Buttons: Apply, Discard

Figure 4.3.1 Instrument Configuration menu

INSTRUMENT NAME

Allows the entry of an alphanumeric name for the recorder, up to 20 characters long. See [section 3.3.1](#) for text entry techniques.

NORMAL/SAVER DISPLAY

Allows normal and 'saver' display brightnesses to be defined. Defaults are Normal = 100%; Saver = 50%.

SAVE AFTER

The number of minutes (between 1 and 99 inclusive), which are to elapse after a screen operation, before the screen brightness changes from 'normal' to 'saver'. Default is one minute.

MODBUS ADDRESS

Allows a Modbus address of between 1 and 247 to be set up for the unit when it is acting as a Modbus slave.

MODBUS SECURITY DISABLED

When using MODBUS, it is possible, by 'checking' this field to allow a host computer to access the recorder without its first having to supply a valid User name and Password. This box must be checked if this unit is acting as a Modbus slave in order for the unit to be detected. Once communications have been established, Modbus security can be enabled, providing that the Slave's Remote user name and password have been entered at the Master. See also section 2.2.4 of the Communications Manual.

COMMS CHANNEL TIMEOUT

Allows a number of seconds (between 1 and 999) to be entered. If none of the channels set to 'Comms' is communicated with, within this period, an event source (Comms channel timeout) is set, and remains set until the next communication. An entry of 0 disables the time out.

PRESET HOUR

Enter an hours number between 0 and 23 for use with Clock Job - Preset clock.

PRESET MINUTE

Enter a minutes number between 0 and 59 for use with Clock Job - Preset clock.

Note: See [section 4.7](#) for a description of recorder jobs, and [section 4.5.1](#) for further details of time synchronisation.

4.3.2 Group configuration

Note: Group 1 is a standard recorder feature. Group 2 is an optional extra

This section allows the user to define, for each group, the following:

- Group trend speed/interval
- Group recording speed/interval
- Group descriptor
- Group content
- Chart grid divisions

The production of alarm messages and the saving of group data to Flash memory, to removable mass storage medium (e.g. floppy disk) and/or to remote computer (FTP transfer) can also be enabled / disabled from this menu.

The screenshot shows the 'Group configuration' menu for 'Group 1'. The settings are as follows:

- Group Number: 1) Group 1 (dropdown menu)
- Trend Units: mm/hr (dropdown menu)
- Descriptor: Group 1 (text field)
- A/B Switching:
- Trend Speed: 1,200 mm/hr
- Trend Interval: 1 s
- Grid Type: From Point (dropdown menu)
- from: Channel 1 (dropdown menu)
- Recording Enable:
- Recording Speed: 1,200 mm/hr
- Recording Interval: 1 s
- Trend History Duration: 25.96 Days
- Archive to Media Enable:
- Archive via FTP Enable:
- Alarm Message:
- Ack Message:
- TurbineTempA:
- TurbineTempB:
- TurbineTempC:
- Etc.

Buttons at the bottom: Apply, Discard.

Annotations in the image:

- Arrows point to the dropdown menus for Group Number, Trend Units, Grid Type, and the 'from' dropdown.
- A box labeled 'Field(s) vary with selected Grid Type' points to the 'from' dropdown.
- A box labeled 'Appear only if 'Recording Enable' is enabled.' points to the Recording Speed, Recording Interval, and Trend History Duration fields.
- A box labeled 'X = Enabled' points to the checked checkboxes.
- A box labeled 'List of all available points (input channels, maths channels, totalisers etc.)' points to the TurbineTempA, TurbineTempB, and TurbineTempC checkboxes.

Figure 4.3.2a Group configuration menu

GROUP NUMBER

Allows group 1 or group 2 (if fitted) to be selected for configuration

TREND UNITS

Allows mm/hr or inches/hour to be selected for the 'chart' speed. Automatically converts the trend speed field below.

DESCRIPTOR

Allows the group name to be edited. See [section 3.3.1](#) for text entry techniques.

A/B SWITCHING

If enabled, this function allows alternative values for Trend speed/interval and Recording speed/interval to be entered. 'A' values are used during normal operation. 'B' values are switched to by job action, as described in [section 4.7](#)

4.3.2 GROUP CONFIGURATION (Cont.)

TREND SPEED/TREND INTERVAL

Allows the 'chart' speed to be selected either as mm or in per hour, or as an interval. Entering a value in one field automatically converts the value in the other field. A trend interval of N seconds is equivalent to $1200/N$ mm/hr chart speed; a chart speed of P mm/hr is equivalent to a trend interval of $1200/P$ seconds.

If A/B switching is enabled, a second Trend Speed /Interval value can be entered. Trend Speed/Interval 'A' is used during normal operation. Trend Speed/Interval 'B' is switched to by job action, as described in [section 4.7](#)

GRID TYPE

Grid type allows the chart grid type to be defined for the group being configured. This is not necessarily related to channel scale ([section 4.3.3](#)), unless 'From point' is selected, when the grid matches the scale of the selected point.

NONE

No chart grid is traced.

LINEAR

The chart grid is linear, with the major and minor divisions defined by the fields Grid Divisions - Major and Minor, which appear if 'Linear' is selected as grid type.

Figure 4.3.2b, below, defines major and minor divisions.

LOG

This menu item appears only if the Log Scales option is fitted.

The chart grid is logarithmic, with the number of decades being selected in the 'Grid Decades' field which appears if 'Log' is selected as Grid Type. Figure 4.3.2b gives an example.

FROM POINT

This allows the chart grid to be aligned with the scale of a particular 'pont', selected in the 'from' field which appears if 'From Point' is selected as 'Grid Type'

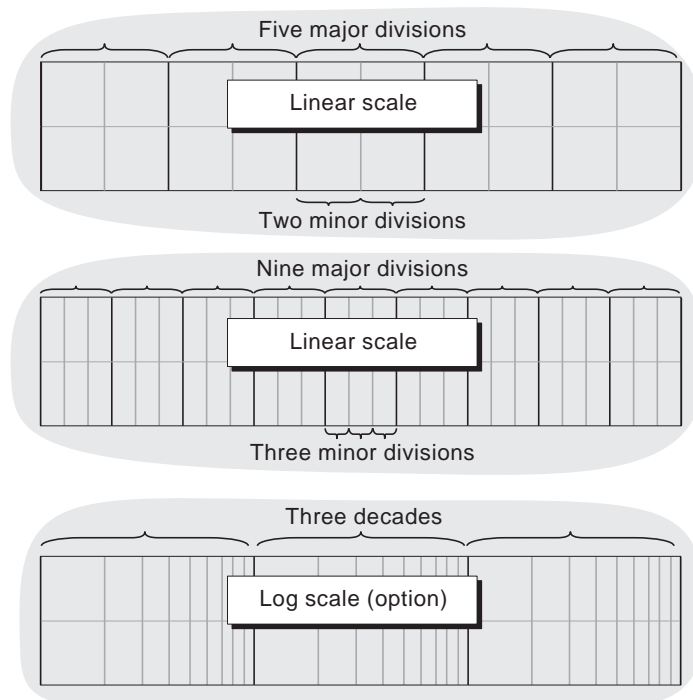

Figure 4.3.2b Chart grid definitions

4.3.2 GROUP CONFIGURATION (Cont.)

RECORDING ENABLE

This tick box allows the logging of this group's data to the Flash memory to be enabled or disabled.

When disabled:

- a The Recording speed/interval fields, described below, do not appear.
- b Display trends are not preserved when changing 'Views'.

Note: If one or more Recording Jobs ([section 4.7.9](#)) are set to act on a group, then the group will be recorded only whilst the job is active, and only if Recording is enabled for the group.

RECORDING SPEED/RECORDING INTERVAL

If Recording is enabled, these fields are as for trend speed/interval but define the rate at which data is saved to Flash memory. This value also affects how much trace history appears per screen height in trend history mode ([section 3.4.1](#)). If recording is not enabled, these fields do not appear.

If [A/B switching](#) is enabled, a second Recording Speed /Interval value can be entered. Recording Speed/Interval 'A' is used during normal operation. Recording Speed/Interval 'B' is switched to by job action, as described in [section 4.7](#).

TREND HISTORY DURATION

Gives an estimated time to fill the group's trend history area of the Flash memory. The calculation is based on the archive rate, the compression ratio, the flash size and on the exact nature of the data. (Rapidly changing values use more space than static/slowly changing values.)

For recorders with two groups, changing the contents of one group may affect the Trend History Duration of the other group. This happens because the recorder attempts to store, as nearly as possible, the same amount of history for both groups, regardless of how many points there are in each group.

For an 'empty' group, the Trend History Duration is displayed as '0' Days

ARCHIVE TO MEDIA/ARCHIVE VIA FTP

If Recording is enabled, these tick boxes allow the archiving of this group's data to removable mass storage media (e.g. floppy disk) and to a remote host (FTP) to be enabled or disabled. If recording is not enabled, these tick boxes do not appear.

Note: For recorders with two groups, it is recommended that only one group be set up for automatic archiving. This is because history files are typically 400kB in size, and this limits the number of files that can be saved, to a 1.4MB floppy disk, to three. If more than one group is set up to archive, and if 'Overwrite' strategy is selected, then it is likely that data for one of the groups will be lost. If an attempt is made to set up more than one group for archiving, the following message appears:

'Not recommended to archive more than 1 group to floppy disk due to limited space - see manual'

ALARM MESSAGE

This box allows the printing of alarm on and off messages on the 'chart' to be enabled (cross) or disabled (no cross) as required. Alarm messages appear on the trend display and in PC Review in the form HH:MM:SS Alarm ON n/m and HH:MM:SS Alarm OFF n/m, where 'n' is the relevant channel number and 'm' is the alarm number (1 or 2).

4.3.2 GROUP CONFIGURATION (Cont.)

ACK MESSAGE

This tick box allows the printing of alarm acknowledgement messages on the 'chart' to be enabled (tick) or disabled (no tick) as required. Acknowledge messages appear on the trend display and in PC Review in the form HH:MM:SS

ALARM ACKNOWLEDGE

Alarms are acknowledged as described in [section 3.1.3](#).

GROUP CONTENTS

This appears as a number of tick-boxes, to include the ticked items in, or to exclude non-ticked items from, the group, as required. Each group may contain any or all of the measuring channels, maths channels (if fitted) and totalisers (if fitted), but only the first 36 will be displayed.

4.3.3 Channel/Alarm configuration

Figure 4.3.3a below, shows a typical configuration menu. The actual fields that appear depend on what input type is selected, what linearisation type is selected, and so on.

The screenshot displays a configuration menu for a channel named '1) TurbineTempA'. The menu includes the following fields and options:

- Channel Number:** 1) TurbineTempA (dropdown menu)
- Value:** 5.003 (text field)
- Input Type:** Thermocouple (dropdown menu)
- Lin Type:** Type K (dropdown menu)
- Range Low:** 0 °C (text field)
- Range High:** 1 °C (text field)
- Range Units:** °C (dropdown menu)
- Scaled:** (checkbox)
- Scale Low:** 0 V (text field)
- Scale High:** 1 V (text field)
- Units:** V (text field)
- Offset:** 0 V (text field)
- Scale Type:** Linear (dropdown menu)
- Scale Divisions - Major:** 5 (text field)
- Scale Divisions - Minor:** 1 (text field)
- Filter:** None (dropdown menu)
- Break Response:** None (dropdown menu)
- Cold Junction Type:** Off (dropdown menu)
- Descriptor:** TurbineTempA (text field)
- A/B Switching:** (checkbox)
- Spanned:** (checkbox)
- Span Low:** 0 V (text field)
- Span High:** 1 V (text field)
- Zone Low:** 0 % (text field)
- Zone High:** 100 % (text field)
- PV Format:** Numeric (dropdown menu)
- Max Decimal Digits:** 4 (text field)
- Colour:** 26 (text field)
- Alarm Number:** 1 (dropdown menu)
- Enable:** Off (dropdown menu)
- Job Number:** 1 (dropdown menu)
- Category:** No Action (dropdown menu)

Buttons at the bottom: Apply, Discard

Figure 4.3.3a Channel/alarm configuration menu (typical)

Notes

1. Numeric values (e.g. 'input low') can be up to 10 characters including decimal point
2. Refer to [section 3.3.1](#) for numeric and text entry techniques.

4.3.3 CHANNEL/ALARM CONFIGURATION (Cont.)

Example: A type J thermocouple is used to measure a temperature range of 100 to 200 degrees Celsius. This thermocouple output is transmitted to the recorder by a 4 to 20 mA transmitter, for display as an efficiency value between 0 and 100%. In such a case, the following values would be set up:

Input type = milliamp
 Input range low = 4.0
 Input range high = 20.0
 Scale low = 0.0
 Scale high = 100
 Scale units = %
 Linearisation range low = 100
 Linearisation range high = 200
 Linearisation type units = degrees C
 Linearisation type = Type J thermocouple.
 Input shunt value = 250 ohms

Note: The following description shows all possible fields. The recorder itself edits the list and shows only those fields appropriate to the setup so far. For example, the 'Shunt' field appears only for mA input type.

CHANNEL NUMBER

The current channel and its descriptor are displayed. Touching the window area allows another channel to be selected for configuration.

VALUE

This field shows the current value of the selected channel along with either 'Unadjusted' or the time and date of adjustment.

INPUT TYPE

Select thermocouple, millivolt, Volt, milliamp, RTD, Ohms, Digital (not channel 1), Slave Comms or Test as input type. Slave Comms must be selected if the channel is to be written-to via Modbus TCP.

LIN TYPE

The following linearisation tables are available as standard:

Linear, square root, $x^{3/2}$, $x^{5/2}$, UserLin1 to UserLin4 (see section 4.3.8 for details).

Thermocouple types B, C, D, E, G2, J, K, L, N, R, S, T, U, NiMo/NiCo, Platinel, Ni/NiMo, Pt20%Rh/Pt40%Rh

Resistance thermometer (RTD) types Cu₁₀, Pt₁₀₀, Pt₁₀₀A, JPT₁₀₀, Pt₁₀₀₀, Ni₁₀₀, Ni₁₂₀, Cu₅₃.

For input ranges, accuracies etc. associated with the above thermocouple/RTD tables, see the specification section (Annex A) of this manual.

INPUT LOW

Enter the lowest value to be applied to the input terminals (e.g.4.00).

INPUT HIGH

Enter the highest value to be applied across the input terminals (e.g. 20.00).

SHUNT

Allows a shunt resistor value to be entered for input type = mA. Commonly used values are 100 ohms and 250 ohms. Note that shunt resistors are connected to the input connector. The recorder cannot detect whether a shunt is fitted, or if one is, what value it has. Therefore it is the responsibility of the user to ensure that the ohmic value of any shunt fitted matches the shunt value entered in this field.

4.3.3 CHANNEL/ALARM CONFIGURATION (Cont.)

RANGE LOW

Enter the lowest value of the required linearisation range (e.g. 100)

RANGE HIGH

Enter the highest value of the required linearisation range (e.g. 200)

RANGE UNITS

Selectable from degrees Celsius, degrees Fahrenheit, Kelvin or Rankine.

SCALED

This box allows the user to select low and high values and units for a scale.

SCALE LOW

Enter the scale value to correspond with input range low (e.g. 0).

SCALE HIGH

Enter the scale value to correspond with input range high (e.g. 100).

SCALE UNITS

Enter up to five characters of unit descriptor (% RH for example).

Note:

User linearisation table units.

The Range Units selection box can be used to set user linearisation table units to temperature units (°C for example).

To enter custom units instead, 'Scaled' must be selected. Scale low and scale high must be set to range low and range high respectively. The required units string is then entered in the Scale Units text entry box.

OFFSET

Allows a fixed value to be added to or subtracted from the process variable. Recorder accuracy figures no longer apply if an offset is included.

SCALE TYPE

This field allows 'None', 'Linear' or (if the Log Scales option is fitted), 'Log' to be selected as scale type. For linear scales, the number of major/minor scale divisions can be selected. This does not affect the 'chart' grid divisions, which is set up as a part of Group configuration ([section 4.3.2](#)).

NONE

Channels with Scale Type selected to 'None', appear with no scale information in any display mode.

LINEAR

Channels with Scale Type = Linear, appear with scale information in all display modes (except numeric). The number of major and minor divisions can be selected from subsequent fields. Examples are shown in figure 4.3.3b, above.

LOG

This menu item appears only if the Log Scales option is fitted.

Channels with Scale Type = Log, appear with logarithmic scales. These scales have major divisions at each decade boundary, and (space permitting), minor divisions for mantissa values 2 to 9. Examples are shown in figure 4.3.3b, below. Because of the nature of logarithms, neither negative values nor the value 0 can be used as scale 'zero'.

4.3.3 CHANNEL/ALARM CONFIGURATION (Cont.)

SCALE TYPE (Cont.)

SCALE DIVISIONS - MAJOR

Appears for Linear Scale types only. Setting major divisions to 1, means that the scale consists only of 'zero' and full scale. Setting Major divisions to 2, means that the scale has divisions at zero, 50% and full scale, and so on. Intermediate scale values appear at major divisions if there is sufficient space.

SCALE DIVISIONS - MINOR

Appears for Linear Scale types only. Setting minor divisions to 1, means that the scale major divisions are not divided i.e. no minor division tick marks appear. Setting Minor divisions to 2, means that each major scale division is divided into two, and so on. See figure 4.3.3b, below, for an example showing five minor divisions.

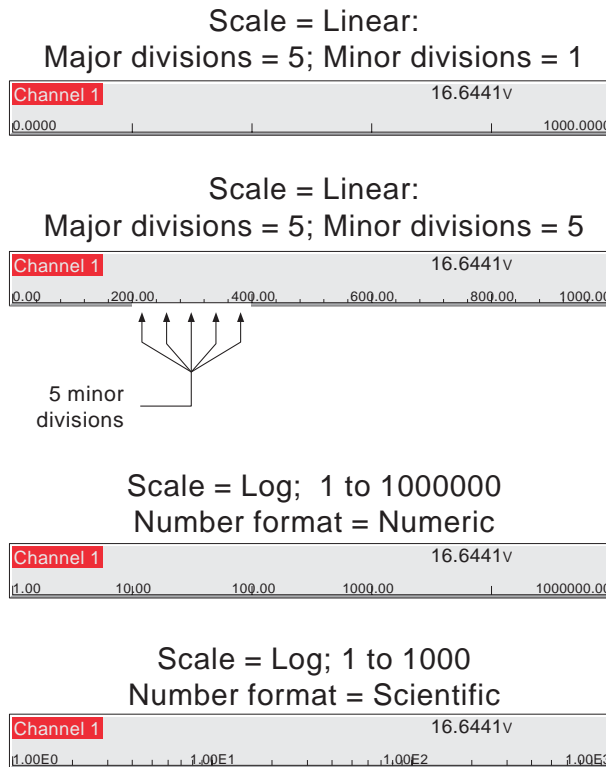

Note that minor divisions and intermediate scale-values appear only if space allows

Figure 4.3.3b Scale Type examples

FILTER

For 'noisy' slowly changing signals, damping can be used to filter noise so that the underlying trend can be seen more clearly. None, 2, 4, 8, 16, 32, 64, 128 or 256 seconds can be selected.

It is not recommended that damping be used on quickly changing signals.

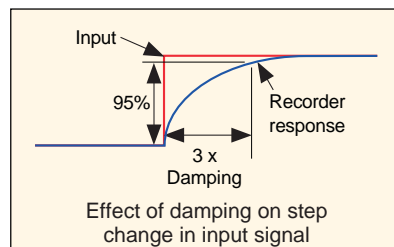

Figure 4.3.3c Channel filter

4.3.3 CHANNEL/ALARM CONFIGURATION (Cont.)

BREAK RESPONSE

For thermocouples and other low level inputs (i.e. input voltages less than 150mV), the recorder can be made to respond in one of the following ways, if a break in the input circuit is detected.

None trace drifts with the input wiring acting as an aerial.

Drive hi trace placed at full scale

Drive lo trace placed at scale 'zero'

COLD JUNCTION COMPENSATION (CJC)

For input type = thermocouple, None, Internal, External or Remote can be selected for cold junction compensation.

INTERNAL

Internal CJC is by means of an RTD connected across pins 11 and 12 of the input board connector.

EXTERNAL

If the cold junction is maintained (by the user) at a known, fixed temperature, 'external' should be selected. An extra numeric entry box appears to allow the user to enter the temperature at which the cold junction is maintained.

Break Response **None** ▼
 Cold Junction Type **External** ▼
 External CJ Temp
 Descriptor **Furnace1 Temp**

REMOTE

'Remote' is selected if the cold junction temperature is to be measured by an external device connected to the instrument.

An extra picklist appears which allows the user to select any input or maths channel to act as the cold junction temperature

source channel. The temperature units displayed here, are those of

the channel being configured, not those of the CJ source channel. The CJ source channel must be configured appropriately for the external device, and must provide a value which is consistent with the configured channel's units.

Break Response **None** ▼
 Cold Junction Type **Remote** ▼
 Remote CJ Temp from **Channel 3** ▼ °C
 Descriptor **Furnace1 Temp**

DESCRIPTOR

Allows a text string of up to 20 characters (including spaces) to be entered for the channel descriptor. (E.G. 'Turbine 2 tempA').

A/B SWITCHING

If enabled, this function allows alternative Span, Zone and Trace Colour values to be entered. 'A' values are used during normal operation. 'B' values are switched to by job action, as described in [section 4.7](#)

SPANNED

This box, when selected, allows span low and high values to be entered. For example, in an input range of 0 to 600 deg C, it may be that the temperature range between 500 and 600 degrees is of most interest. In such a case, setting span low to 500 and span high to 600 will cause the recorder to display only that part of the input range, and this will fill the zone width which is selected next, effectively magnifying the area of interest.

If A/B switching is enabled, a second set of span low and span high values can be entered. 'A' values are used during normal operation. 'B' values are switched to by job action, as described in [section 4.7](#).

4.3.3 CHANNEL/ALARM CONFIGURATION (Cont.)

ZONE

This allows the portion of the chart which the channel occupies to be defined in terms of percent, where the left edge of the chart is 0% and the right hand edge is 100%. For example, setting a low value of 50 and a high value of 100 causes the channel trace to be confined to the right hand half of the chart.

If A/B switching is enabled, a second set of zone low and zone high values can be entered. 'A' values are used during normal operation. 'B' values are switched to by job action, as described in [section 4.7](#).

PV FORMAT

This allows the PV value, alarm setpoints, hysteresis values etc. to be displayed as normal numeric values (Numeric) or in 'Scientific' format (Scientific). When 'Scientific' is selected, values are displayed and entered as a decimal number between 1 and 10[†] (the mantissa), followed by a multiplier (the exponent). E.G. to enter a value of 1244.5678, the value entered would be 1.2445678E3, where 3 represents the number of places that the decimal point must be shifted to the left in order to convert the value to a number between 1 and 10[†]. To enter a value of 0.0004196, the entry would be 4.196E-4.

[†] Notes

1. Strictly this is a number less than 10, as 10 would be 1.0E1.
 2. There must be at least one number after the decimal point.
-

MAXIMUM DECIMAL DIGITS

This defines the number of decimal places in the process value. Settable between zero and nine. Leading and trailing zeros are not displayed. Values too long for the available displaying width are truncated as described in [section 3](#).

COLOUR

Allows the trace colour to be selected from a colour chart. Each of the 56 available colours is displayed with a number, and it is this number which is entered. The background colour to the selection box changes to the selected colour.

If A/B switching is enabled, a second colour selection can be entered. Colour 'A' is used during normal operation. Colour 'B' is switched to by job action, as described in [section 4.7](#)

4.3.3 CHANNEL/ALARM CONFIGURATION (Cont.)

ALARM NUMBER

Allows an alarm to be selected for configuration. (One or two for 16MB DRAM recorders; one to four for 32MB versions.)

ENABLE

Allows the alarm to be defined as Off, Unlatched, Latched or Trigger

Off	Alarm is disabled and the remainder of the alarm configuration is hidden.
Unlatched	Unlatched alarms become active when the trigger source becomes active and remain active until the source returns to a non-active state. The indicator is on (flashing before acknowledgment - steady after acknowledgement) until the alarm clears. Alarm messages are printed if enabled in group configuration.
Latched	Latched alarms become active when the trigger source becomes active and remain active until the alarm is acknowledged AND the trigger source has returned to a non-active state. The indicator is on (flashing before acknowledgment - steady after acknowledgement) until the alarm has been acknowledged AND the trigger source has returned to a non-active state. Alarm messages are printed if enabled in group configuration. Continuous jobs remain active only whilst the alarm trigger source is active. I.E. the job finishes when the alarm clears, whether acknowledged or not.
Trigger	When triggered all associated jobs are initiated, and continuous jobs remain active until the alarm clears. There is no alarm indication, and no messages are printed.

TYPE

This field appears only when the alarm Enable is not selected Off. Each alarm can be defined as absolute high, absolute low, deviation-in, deviation-out, rate-of-change rise or rate-of-change fall.

Absolute High	As shown in figure 4.3.3d, an absolute high alarm becomes active when the channel value exceeds the threshold value. The alarm remains active until the channel value falls below (Threshold minus hysteresis). If a dwell value is defined, the alarm does not become effective until this dwell time has been exceeded.
Absolute Low	As shown in figure 4.3.3d, an absolute low alarm becomes active when the channel value falls below the threshold value. The alarm remains active until the channel value exceeds (Threshold + hysteresis). If a dwell value is defined, the alarm does not become effective until this dwell time has been exceeded.
Deviation in	As shown in figure 4.3.3e, a deviation-in alarm becomes active whenever the channel value enters the band: Reference \pm Deviation. It remains active until the channel value leaves the band: Reference \pm (Deviation + Hysteresis). If a dwell value is defined, the alarm does not become effective until this dwell time has been exceeded.
Deviation out	As shown in figure 4.3.3e, a deviation-out alarm is active whenever the channel value leaves the band Reference \pm Deviation. It remains active until the channel value enters the band: Reference \pm (Deviation - Hysteresis). If a dwell value is defined, the alarm does not become effective until this dwell time has been exceeded.
Rate of change	As shown in figure 4.3.3f, rate of change alarms become active whenever the signal value changes by more than a specified amount within a specified period. If a dwell value is defined, the alarm does not become effective until this dwell time has been exceeded. An averaging period can be set to remove the effects of sudden, but short-lived changes, such as noise spikes on the signal.

Note: Alarm icons appear at the display, as described in section 3 of this manual.

4.3.3 CHANNEL/ALARM CONFIGURATION (Cont.)

PARAMETERS

Figures 4.3.3d, e and f illustrate the following terms for the different alarm types.

Threshold	For Absolute alarms, this defines the value (in engineering units) at which an alarm is triggered. The alarm also returns to its non-active state at this value unless a threshold value has been set. If a dwell value is set, the alarm does not become active until this dwell time has elapsed.
Hysteresis	Defines a 'deadband' (in engineering units) to eliminate spurious triggering if the signal value is hovering around the trigger point. The deadband lies: Below Absolute High thresholds Above Absolute Low thresholds Outside the deviation band for Deviation-in alarms Inside the deviation band for Deviation-out alarms.
Dwell	Allows a dwell period to be entered in seconds. The alarm does not take effect until this period has expired. If an alarm clears before the dwell period has expired, the alarm is ignored.
Reference	For Deviation alarms, this is the central value of the deviation band.
Deviation	For Deviation alarms, this value defines the width of the deviation band, each side of the reference value. I.E. the total width of the deviation band is 2 x Deviation value.
Amount	For Rate-of-change alarms, this value defines the amount by which the signal value would have to change, within the 'Change Time' period (below), in order for the alarm to become active.
Change Time	For Rate-of-change alarms, this selects the time period (Per second, Per minute, Per hour) within which the change in signal value must exceed the Amount value (entered in the preceding field) in order for the alarm to become active.
Average time	For rate-of-change alarms, this allows an average period to be entered for signal smoothing.

EXAMPLE

Threshold = 100 units; Hysteresis = 5 units
A high alarm becomes active when its input rises above 100 and remains active until its value falls below 95 units. A low alarm becomes active when its input falls below 100 units, and remains active until its input rises above 105 units.

4.3.3 CHANNEL/ALARM CONFIGURATION (Cont.)

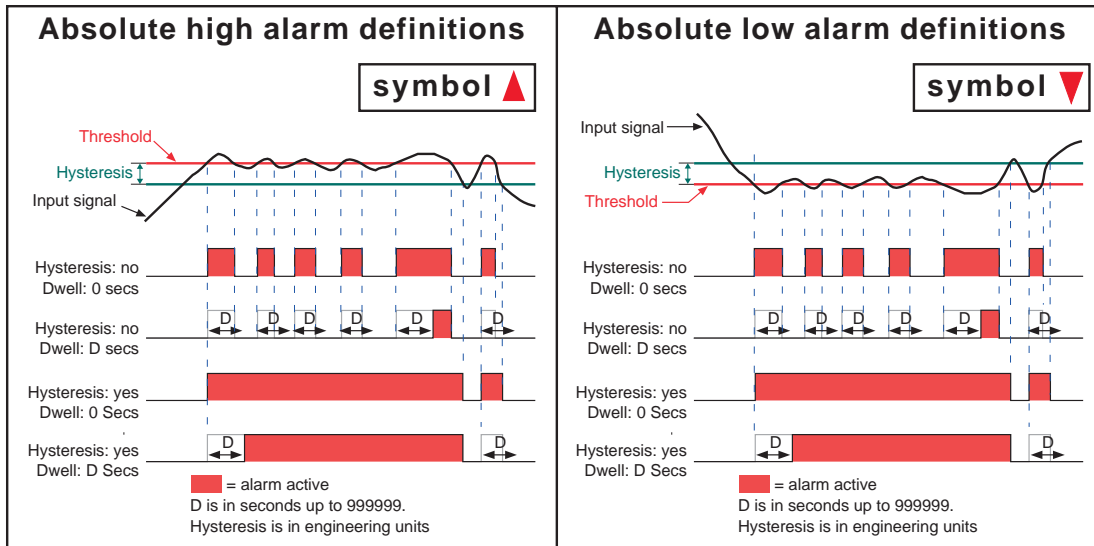

Figure 4.3.3d Absolute alarm definitions

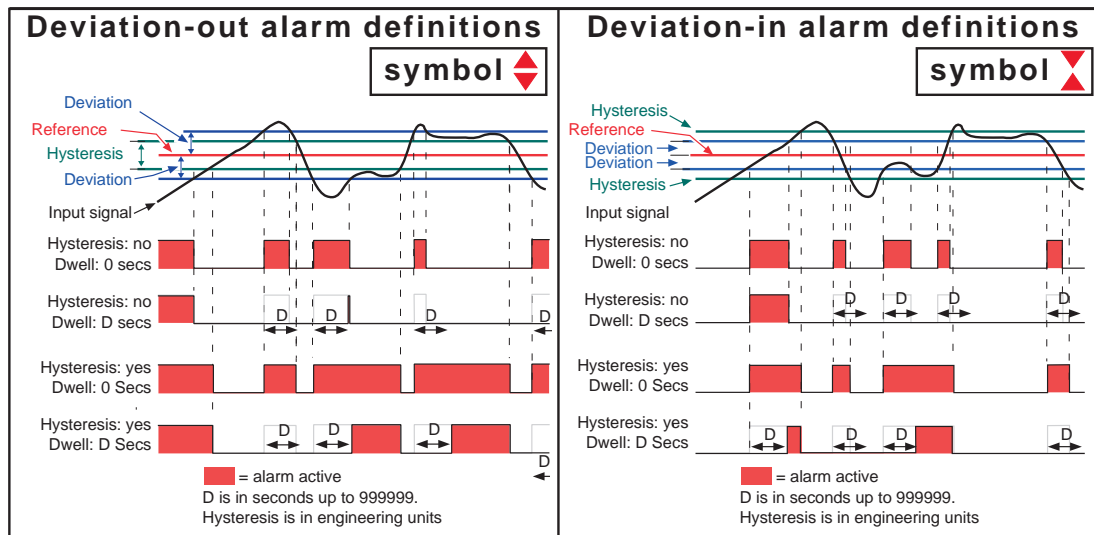

Figure 4.3.3e Deviation alarm definitions

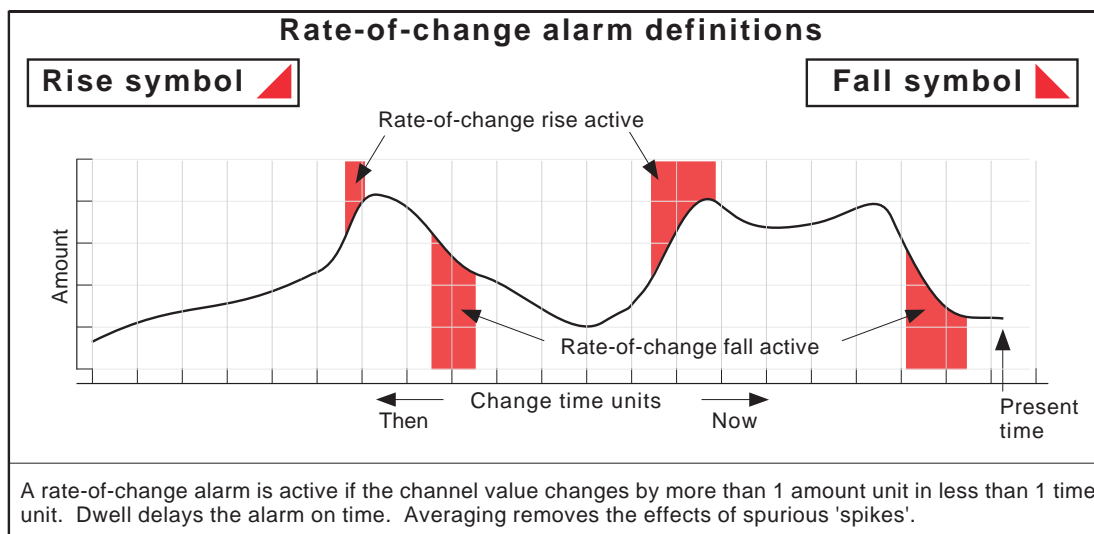

Figure 4.3.3f Rate-of-change alarm definitions

4.3.3 CHANNEL/ALARM CONFIGURATION (Cont.)

JOB NUMBER

Only Job 1 is available

CATEGORY

Select the required job to be carried out when the channel is in alarm (e.g. Drive relay. See [section 4.7](#) for Jobs description).

WHILE/ON

Allows the action of the job to be selected as:

1. whilst active, whilst inactive or whilst unacknowledged or
2. on becoming active, on becoming inactive or on acknowledgement according to job type.

Figure 4.3.3g, below, shows the various actions graphically. For 'While unacknowledged' and 'on acknowledgement' settings, two cases are shown, one where the alarm goes inactive before acknowledgement; the other where the alarm is acknowledged whilst the alarm is still active. The coloured (shaded) areas show the duration for which continuous jobs run; the down arrows show trigger points for 'one-shot' jobs. See [section 3.1.3](#) for details of how to acknowledge alarms.

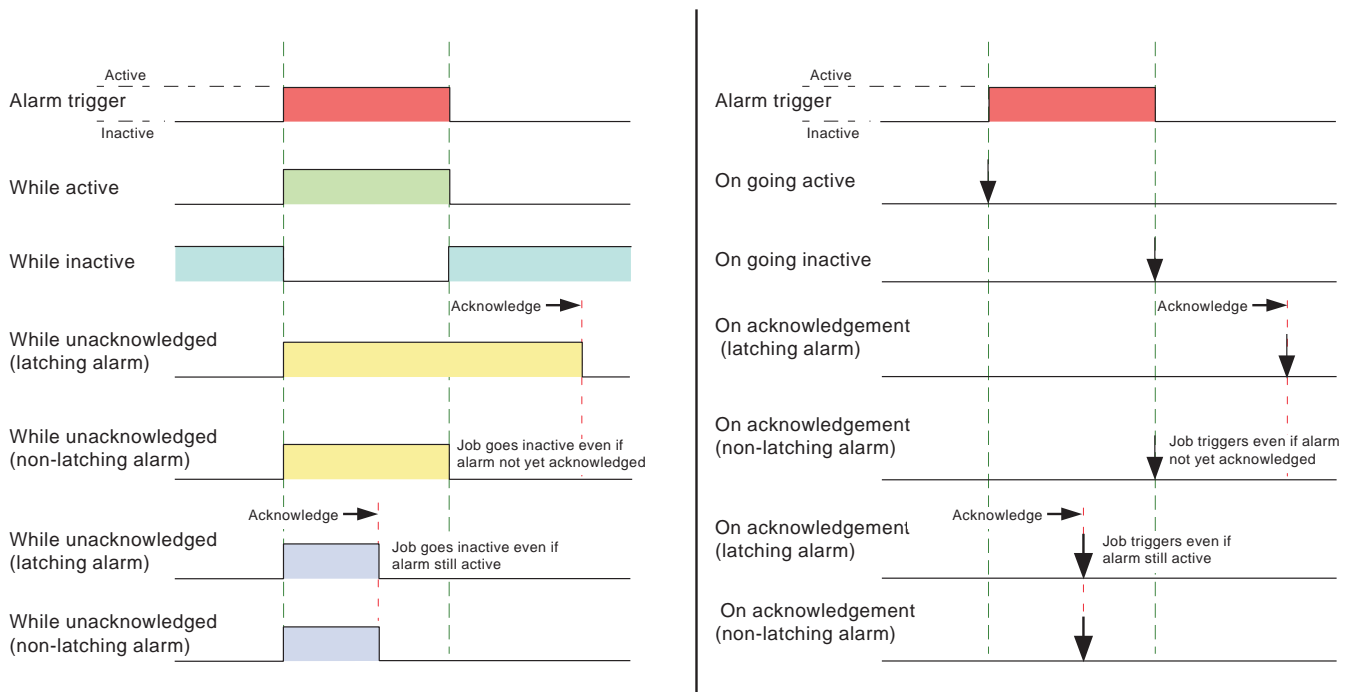

Figure 4.3.3g Graphical representation of job actions

ALARM MESSAGES

Alarm on/off and alarm acknowledge message printing on the chart can be enabled/disabled as a part of 'Group configuration' described below. Alarms are acknowledged by touching the (flashing) alarm icon at the top of the screen, then touching the 'Ack all Alarms' key followed by the confirmation 'Yes' key ([section 3.1.3](#)).

4.3.4 Views Configuration

This part of the recorder's configuration allows groups to be set up (individually or globally) to include the various display modes described in [section 3.4](#), above.

When enabled, display modes become selectable in the [Root 'Goto View'](#) menu.

Home Group and Home Page picklists allow a group and display mode to be defined for display when the Home key is pressed in the [Root](#) menu.

The screenshot shows the Views Configuration menu with the following fields and controls:

- Home Time-out: 0 Minutes
- Home Group: 1) Group 1 (dropdown) → Select group for Home display
- Dark Trend Background:
- Dark History Background:
- Scope: Group (dropdown) → Select Instrument or Group
- Group: 1) Group 1 (dropdown) → Select group for display mode enable
- Display enable: (A callout box points to this field with the text: "These fields appear only if Scope = 'Group'")
- Home Page: Numeric Page (dropdown) → Select Home display mode for instrument or for selected group
- Vertical Trend:
- Horizontal Trend:
- Vertical Bargraph:
- Horizontal Bargraph:
- Numeric Page:

A legend box at the bottom right of the menu states: **X = Enabled**. At the bottom of the menu are "Apply" and "Discard" buttons.

Figure 4.3.4a Views Configuration menu

HOME TIMEOUT

The recorder returns to the specified home page after the timeout value of minutes has elapsed since the last touch on the display. Timeout action is inhibited if a configuration is incomplete (there are changes which have not been 'Applied'), or if a system-generated message (e.g. 'Clock Failure') is on display. User displays (e.g. Root menu) are time-out after approximately 50 seconds.

A value of zero disables the time-out function. Valid entries are between 1 and 99 minutes

HOME GROUP

This picklist allows a particular group to be selected for display when the root menu 'Home' key is pressed.

DARK TREND/DARK HISTORY BACKGROUND

These tick boxes allow the user to select a black 'chart' for normal trending and/or trend history mode. These selections act globally (i.e. on all groups) and are alternatives to the normal white-chart trend displays, not additional to them.

4.3.4 VIEWS CONFIGURATION (Cont.)

SCOPE

The remaining items of Views configuration can be selected to act globally (Instrument) or to act on individual groups (Group). When 'Instrument' is selected, enabled display modes appear in all groups' Root 'Goto View' menu (Figure 4.3.4b). When 'Group' is selected, each group can be set up with its own active display modes.

For the particular group on display, the Root menu 'Goto View' key used to select the required display modes from those which have been enabled. Display modes which are not enabled are 'greyed' in this menu..

GROUP

This field appears only if 'Scope' is set to 'Group', and allows each group to be selected for display configuration. For other items of [Group Configuration](#) see section 4.3.2.

Note: Group 1 is a standard recorder feature. Group 2 is an optional extra.

DISPLAY ENABLED

This field appears only if 'Scope' is set to 'Group', and allows the selected group to be enabled or disabled for display. When enabled, the group can be displayed by using the 'Root menu/Goto Group/Group N' selection. When disabled, the group is 'greyed' in the 'Root menu/Goto screens/Group N' selection. It is not possible to disable the Home group.

HOME PAGE

Allows a particular display mode to be selected as the default display, either for all groups (Scope = instrument) or on a group-by-group basis (Scope = group).

DISPLAY MODE ENABLING

A series of check boxes allow the various display modes to be added to (or removed from) the Root menu 'Goto View' menu (figure 4.3.4b), either for all groups (Scope = instrument) or on a group-by-group basis (Scope = group). It is not possible to disable the selected Home page mode.

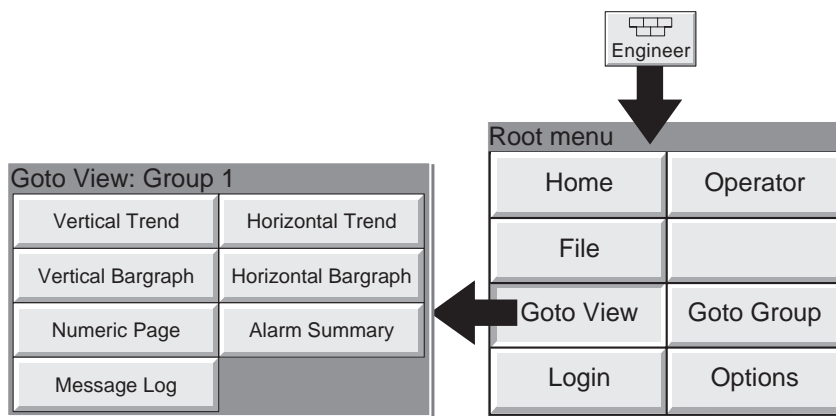

Figure 4.3.4b Goto View menu

4.3.5 Archive configuration

This allows an archive strategy to be set up for saving data to disk or (if the Ethernet option is fitted) to a remote PC. The disk strategy includes archive period, disk full operation, compression factor and an estimate of how much archive period is left in the recorder memory and on the disk. The recorder uses a dedicated area of its Flash memory as an archive data buffer; data is written to the disk or remote PC only when required, rather than continuously.

If the CSV option is fitted, then files can be archived in Comma Separated Values (CSV) format and/or the standard Packed Binary (uhh) format. CSV format files are not as secure as Packed Binary format files are.

In order to carry out a successful remote archive, details of the remote host must be entered both in this Archive section of the 'Config' menu, and in Network configuration ([section 4.5](#)). Further, the current access level must have 'Connect from remote' enabled in the Security/Access menu ([section 4.4.1](#)).

Compression **Normal** ▼ → Select: Normal or High
Flash Size **2.75** Mb
Shortest Trend History **Group 1**
Duration **7.28** Days
Show **Disk settings** ▼ → Select 'Disk' or 'Remote' settings
Media File Format **Binary** ▼ → Appears only if CSV option is fitted
Archive to Media **None** ▼ → Select: Archive interval
On Media Full **Overwrite** ▼ → Select: Overwrite or Stop
Media Size **1.38** Mb
Disk Archive Capacity **3.57** Days
Media Full event limit **100** %

Apply Discard

Figure 4.3.5a Archive configuration menu (Disk settings)

Compression **Normal** ▼ → Select: Normal or High
Flash Size **2.75** Mb
Shortest Trend History **Group 1**
Duration **8.71** Days
Show **Remote settings** ▼
Archive to Remote **None** ▼ → Select archive interval
Ftp File format **Binary** ▼ → Appears only if CSV option fitted
Remote path **/recorder/Group1**
Primary remote host **0.0.0.0**
Primary login name **anonymous**
Primary password *********
Retype password *********
Secondary remote host **0.0.0.0**
Secondary login name **anonymous**
Secondary password *********
Retype password *********

Apply Discard

Figure 4.3.5b Archive configuration menu (Remote settings)

4.3.5 ARCHIVE CONFIGURATION (Cont.)

COMPRESSION

Select Normal or high compression. 'Normal' compresses the data but still provides an exact copy. 'High' compresses more, but channel values are saved only to 1 part in 10⁸ resolution.

FLASH SIZE

Allows the size of the Flash memory to be viewed by the user.

SHORTEST TREND HISTORY / DURATION

This shows which group has the shorter amount of Flash memory allocated to its history record. Providing the archive period is less than the value displayed in the Duration window, no data will be lost from either group. If the archive period is greater than this value, then some of the data in one or both groups will have been overwritten and therefore lost.

If both groups have the same Shortest Trend History Duration, Group 1 is displayed.

Note: Trend history duration depends on many factors, as described in [Group Configuration](#) (section 4.3.2). above.

CSV CHECKBOXES, DATE/TIME FORMAT

These checkboxes appear only if 'CSV' or 'Binary and CSV' has been selected in the ftp file format field, described below. refer to the CSV section at the end of this subsection (4.3.5)

SHOW

This allows the fields which are to appear below 'Show' to be applicable to disk (Disk Settings), or to the setting up of a remote host path for archiving purposes (Remote settings). The following descriptions contain all the fields which may appear in either menu.

ARCHIVE TO MEDIA

None	Archive to disk is initiated by the operator (section 4.1)
Hourly	Archive to disk occurs on the hour every hour
Daily	Archive to disk occurs at 00:00* hrs each day
Weekly	Archive to disk occurs at 00:00* hrs every Monday
Monthly	Archive to disk occurs at 00:00* hrs on the 1st of each month
Automatic	The recorder selects the slowest out of Hourly, Daily, Weekly or Monthly, which is guaranteed not to lose data. This is calculated according to which of the trend history buffer or the disk is the smaller. The recorder assumes that the disk is 'empty' when making these calculations.

**Note:* Archive times are not adjusted for Daylight Saving hour changes. Thus if the archive is set to 'daily', 'weekly' or 'monthly' then, during 'Summer Time', the archive will occur an hour late (i.e. at 01:00 hrs. instead of midnight).

MEDIA FILE FORMAT/FTP FILE FORMAT

This appears only if the CSV option is fitted, for 'Remote settings' only. Allows 'Binary' (.uhh) format, 'CSV' (.csv) format, or both, to be selected for FTP transfer. See the CSV description later in the subsection (4.3.5).

4.3.5 ARCHIVE CONFIGURATION (Cont.)

MEDIA FULL OPERATION

For Disk Settings only:

Overwrite Oldest data replaced with latest data when disk is full
Stop Archiving stops when the disk is full

Notes

1. The maximum number of history files (total for both groups) is 750 per directory.
 2. When in 'Overwrite' mode, the recorder will overwrite only those files which it has itself created. Thus, if a disk is inserted which contains history files from another recorder, these cannot be overwritten. The file names are of the form UUU . . . UUUIIIIIIFFGSSSSSS, where IIIIII represent the lowest three bytes of MAC address of the recorder which created the file (see [section 4.5.1](#)). It is not possible for the user to delete files created by another instrument (i.e. one with another MAC address).
-

MEDIA SIZE

For Disk Settings only, allows the size of the Disk to be entered, for user information only. This item is not saved as part of the configuration.

DISK ARCHIVE CAPACITY

For Disk Settings only, this gives an estimated time to fill the disk, based on the archive rate, the compression ratio, the disk size and on the exact nature of the data. (Rapidly changing values use more space than static/slowly changing values.)

MEDIA FULL EVENT LIMIT

For disk settings only, this allows the user to specify a percentage-full value for the disk or pc card, at which the event source 'Archive media % full' is triggered. The event remains active until the disk or pc card is replaced, or has data removed from it to make more room available.

ARCHIVE TO REMOTE

Note: Archive to remote is available only if the Ethernet option is fitted

For Remote settings only:

None Archive to host is initiated by the operator ([section 4.1.2](#))
Hourly Archive to host occurs on the hour every hour
Daily Archive to host occurs at 00:00* hrs each day
Weekly Archive to host occurs at 00:00* hrs every Monday
Monthly Archive to host occurs at 00:00* hrs on the 1st of each month
Automatic The recorder selects the slowest out of 'Hourly', Daily, Weekly or Monthly, which is guaranteed not to lose data (depends on the size of the Trend History Buffer).

*Note: Archive times are not adjusted for Daylight Saving hour changes. Thus if the archive is set to 'daily', 'weekly' or 'monthly' then, during 'Summer Time', the archive will occur an hour late (i.e. at 01:00 hrs. instead of midnight).

REMOTE PATH

For Remote settings only:

The route to a folder or directory on the remote host, set up as a part of that host's FTP configuration

4.3.5 ARCHIVE CONFIGURATION (Cont.)

PRIMARY REMOTE HOST

For Remote settings only:

If a Domain Name Service (DNS) is specified in the Network key 'Name' page (fig 4.5.2), then the Primary Remote Host is the server name. If DNS is not selected, then the Primary Remote Host is the IP address of the remote host, set up in the host's Control Panel\Network.

PRIMARY LOGIN NAME/PASSWORD

For Remote settings only:

Login name and password of the remote host account assigned either by the Network administrator, or in the Guest account of the remote host's FTP services or User Manager configuration. The password, which must be of between eight and 20 characters, must be entered twice to ensure integrity.

SECONDARY REMOTE HOST/LOGIN/PASSWORD

For Remote settings only:

As for primary versions, but for a secondary host. The secondary route is used only if the primary route fails.

CSV OPTION

This allows archive files to be transferred in comma-separated-values (CSV) format to disk or a remote host PC via FTP).

The screenshot shows a configuration window for archive settings. The 'CSV option' is highlighted with a rounded rectangle. The settings are as follows:

- Compression: Normal (dropdown), Binary format only (checkbox)
- Flash Size: 13.25 Mb
- Shortest Trend History: Group 1
- Duration: 19.02 Days
- CSV include Values:
- CSV include Messages:
- CSV include Header details:
- CSV include Column headings:
- CSV Date/Time format: Text (dropdown)
- CSV use Tab delimiter:
- Show: Remote settings (dropdown)
- Archive to Remote: Hourly (dropdown)
- Ftp file format: Binary and CSV (dropdown)
- Remote path: /recorder/Group1
- Primary remote host: 0.0.0.0
- Primary login name: anonymous
- Primary password: *****
- Retype password: *****
- Secondary remote host: 0.0.0.0
- Secondary login name: anonymous
- Secondary password: *****
- Retype password: *****

Buttons for 'Apply' and 'Discard' are at the bottom.

Figure 4.3.5c Archive menu items - CSV option fitted.

MEDIA/FTP FILE FORMAT

This allows 'Binary', 'CSV' or both to be selected for file type when archiving. 'Binary' is the proprietary format used by the instrument and it requires other software (e.g. Review Software) to interpret the data, before it can be presented in spreadsheets, shown as if on a chart etc. Binary files have the extension '.uhh'.

4.3.5 ARCHIVE CONFIGURATION (Cont.)

MEDIA/FTP FILE FORMAT (Cont.)

CSV format is a standard open-file format for numeric data. A simple ASCII-based format, it is readable by a wide range of PC applications as well as being suitable for direct import into many commercial databases. CSV files have the extension '.csv'.

Note: CSV is ASCII based, and cannot interpret Unicode characters. Some characters available to the user will therefore be displayed incorrectly in CSV files.

If 'CSV' or 'Binary and CSV' is selected, a number of extra checkboxes appear. Figure 4.3.5c above shows a typical menu page. Figure 4.3.5d, below, shows the effects of enabling the CSV checkboxes, with the exception of 'CSV use Tab delimiter' the use of which is as follows:

CSV USE TAB DELIMITER

Despite its name, CSV does not always use commas as separators.

For example, in some countries, the decimal point is represented by a full stop (period), whilst in other areas, a comma is used. In order to avoid confusion between the comma as a decimal point and the comma as a separator, a different separator is used, usually the semicolon.

The instrument automatically chooses a separator suitable for use with the 'Locale' selected in System Configuration (section 4.6.2). 'CSV Use Tab delimiter' allows the user to override this choice, and force the instrument to use tabs as separators. This can be particularly useful when moving the data from one locale to another.

CSV DATE/TIME FORMAT

Allows 'Text' or Spreadsheet numeric to be selected. Text causes a time/date to appear in the spreadsheet. Spreadsheet numeric displays the number of days since December 30th 1899. The decimal part of the value represents the latest 6 hours, so DDD---DDD.25 represents 0600 hrs, DDD---DDD.5 represents noon etc. Numeric format is more easily interpretable by some spreadsheets, than Text format is.

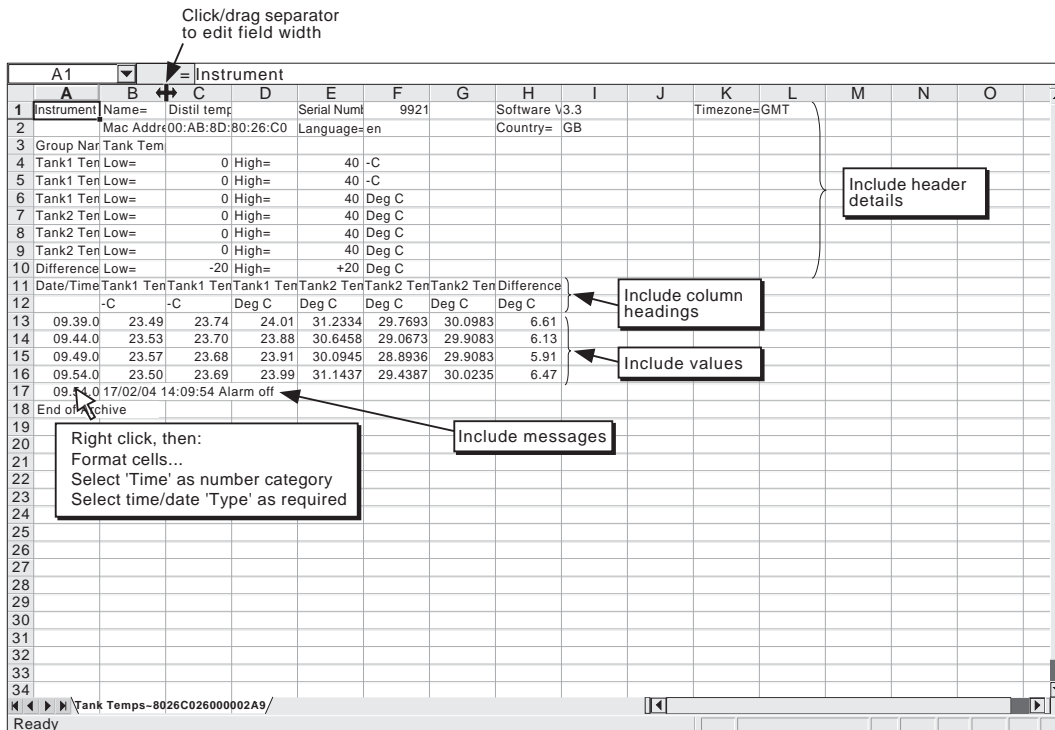

Figure 4.3.5d CSV data example

4.3.6 Event configuration

A number of internal alarm sources (events) are available for use in running a job list when triggered. Events can have up to two sources each, but can themselves be used as sources allowing a large number of inputs to be used. Input sources can be logically combined, and can be inverted if required.

The screenshot shows a typical event configuration menu with the following fields and options:

- Event Number: 1) Event 1 (dropdown) → Select 1 to 6
- Source 1: Alarm on Group (dropdown) → Select source 1
- On Group: 1) Group 1 (dropdown) → Make source 1 sub selection (if any)
- Source 2: Point Alarm (dropdown) → Select source 2
- On: Math 12 (dropdown) → Make source 2 sub selection (if any)
- Alarm: 2 (dropdown) → Make sub-sub selection (if any)
- Source 1 Sense: Source 1 (dropdown) → Select source inversion or not
- Operator: And (dropdown) → Select logic combination: Only, AND, OR, NAND, NOR, XOR.
- Source 2 Sense: Not Source 2 (dropdown) → Select source inversion or not
- Descriptor: Event 1 (text input)
- Job Number: 1 (dropdown) → Select: 1 or 2
- Category: No Action (dropdown) → Select Job Category

Buttons: Apply, Discard

Figure 4.3.6 Event configuration menu layout (typical)

EVENT NUMBER

Allows the required event (1 to 6) to be selected for configuration.

SOURCE TYPES

Off	The event is disabled
Global alarm	The event is active whilst any one or more alarms is active
Global Unack'd alarm	The event is active as long as there is an unacknowledged alarm present.
Comms channel timeout	The event is set if no communication has been made with 'Comms' channels within the Comms channel timeout period set in Instrument configuration (section 4.3.1). The source is reset when the next communication occurs.
Timer active	The event is triggered when a specified timer becomes active (section 6 of the Options manual). If the Timers option is not fitted, 'Timer Active' does not appear in the picklist.
Event	Allows another event to be specified as a source.
Point alarm	Triggered by the specified alarm on the specified point.
Unack'd point alarm	Triggered by the specified alarm on the specified point. Remains active until the alarm is acknowledged (section 3.1.3).
Alarm on Group	Triggered if any alarm in the specified group becomes active.
Unack'd Alarm on Group	Triggered if any alarm in the specified group becomes active. The event remains active until the alarm is acknowledged.
Instrument alarm	This source triggers an event if any of the following becomes active: Any, Input channel failure, Removable media failure, Removable media full, No removable media fitted, FTP primary server failure, FTP secondary server failure, Maths channel failure, Clock failure, Unrecognised PC card, Recording failure - overflow, Floppy disk worn, Floppy disk corrupt, Network Boot failure, SNTP server failure, Time Synchronisation Failure, Battery backed RAM cleared. The event remains active until the instrument alarm clears. See section 3.1.3 for more details of instrument alarms.

4.3.6 EVENT CONFIGURATION (Cont.)

EVENT SOURCES (Cont.)

Power up	A transient event is triggered at power up.
Maths channel partial failure	For recorders fitted with the Maths pack option, this event is set if, say, one of the inputs to a group averaging function becomes invalid. In such a case, the average will be calculated on the remaining input values, but the result may not be as accurate as expected. Loss of one input can also be important in functions such as Fvalue, where several sensors may be distributed within the load and their outputs used in a group minimum calculation for input into the Fvalue equation.
Battery Low	This event is set when the battery is reaching the end of its useful life. The event remains active until the battery is replaced.
Archive media % full	Triggered when the floppy disk or PC card has reached the % fullness defined in Archive configuration (section 4.3.5).
Invalid Password Entry	Transient event at the point of an invalid password entry attempt
User Logged In	This event becomes active whenever a user with the specified Event Permission logs in. The event remains active until all local and remote users, with the specified permission, have logged out. See also section 4.4.1 (Access levels).
Email Failure	This event source appears only if the e-mail option is fitted (options manual section 11), and is triggered if an attempt to send an e-mail is unsuccessful.

SOURCE 1 SENSE

Allows source 1 to be used in its normal sense (Select 'Source 1') or inverted (Select 'Not Source 1').

Example: Source 1 is alarm 1 on channel 3

With Source 1 Sense = Source 1, the event is active whenever channel 3 alarm 1 is active.

With Source 1 Sense = Not Source 1, the event is active whenever the alarm is not active.

OPERATOR

This allows a logical combination of input sources to be used to trigger an event. The selections and their definitions are shown in table 4.3.6, below.

Operator	Event active when:	Event not active when:
Only	S1 Active	S1 not active
AND	S1 and S2 both active	S1 and/or S2 not active
OR	S1 and/or S2 active	S1 and S2 both not active
NAND	S1 and/or S2 not active	S1 and S2 both active
NOR	S1 and S2 both not active	S1 and/or S2 both active
XOR	S1 or S2 active	S1 and S2 both active or both not active
S1 = Source 1; S2 = Source 2		

Table 4.3.6 Logical operators for event sources

SOURCE 2 SENSE

Allows source 2 to be used in its normal sense (Select 'Source 2') or inverted (Select 'Not Source 2').

Example: Source 2 is Group 1 Batch Running

With Source 2 Sense = Source 2, the event is active whilst the batch is running.

With Source 2 Sense = Not Source 2, the event is active whilst the batch is not running.

4.3.6 EVENT CONFIGURATION (Cont.)

DESCRIPTOR

Allows a text string to be entered as the event title. See [section 3.3.1](#) for text entry techniques.

JOB NUMBER

Only Job 1 is available.

CATEGORY

Select the required event job to be carried out (e.g. Drive relay). See [section 4.7](#) for Jobs description.

WHILE/ON

Allows the action of the alarm job to be chosen as

- a. whilst active, whilst inactive or whilst unacknowledged for continuous jobs (e.g. drive relay), or,
- b. on going active, on going inactive or on acknowledgement for 'one-shot' jobs (e.g. increment counter).

See also [figure 4.3.3g](#) and associated text.

EVENT EXAMPLE

An event is to be active whenever Channel 1 Alarm 1 is active whilst Channel 3 alarm 2 is not active.

Source 1 = Point alarm (On = Channel 1; Alarm = 1)

Source 2 = Point alarm (On = Channel 3; Alarm = 2)

Source 1 Sense = Source 1

Operator = And

Source 2 Sense = Not Source 2

It is possible to achieve the same result by inverting both Source senses and using the Nor operator.

4.3.7 Messages

This feature allows messages to be sent, by job action (section 4.7), to the display, to a specified group or to all groups. Messages can also be included in e-mails (Options manual, section 11) if the relevant option is fitted. The messages are of the form: Date, Time, Message. The message can be just text (up to 80 characters), or it can include up to nine embedded items which are typed into the message as {1} to {9}. The embedded values represented by {1} to {9} are selected from picklists.

If a Group-destination message contains more characters than can be displayed on the screen (depends on recorder model), the right-hand part of the message is invisible to the user. The message appears in full in the [message log](#) and when Review Software is used. Display-destination messages are always fully visible.

MESSAGE ENTRY

The message configuration page is shown below in figure 4.3.7 The page is accessed from the Root menu/Operator/Config menu.

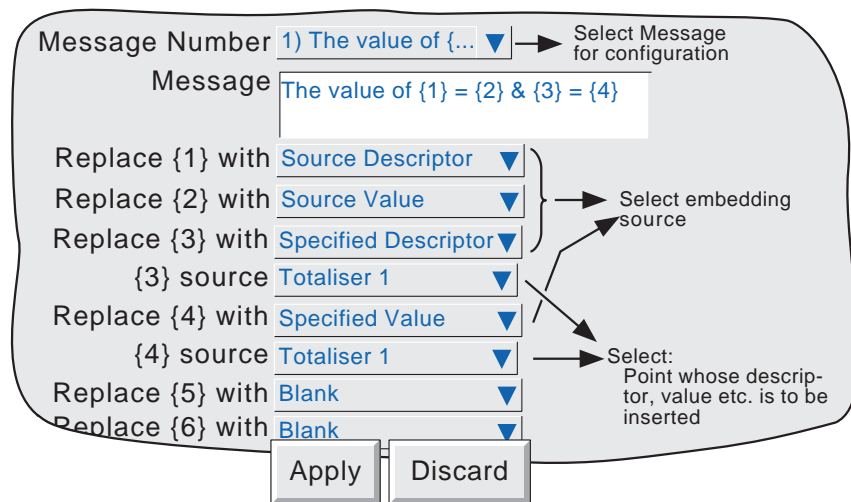

Figure 4.3.7 Message entry configuration page.

CONFIGURABLE PARAMETERS

- Message Number Select the required message from the picklist. Copies whole 'Message' text (when entered) if less than 17 characters; displays first 14 characters of longer messages.
- Message Enter the message by using the pop-up keyboards (section 3.3.1)
- Replace {n} with A picklist allowing the user to select data to be embedded in the message:
 - Source Descriptor:** The descriptor of the source which triggers the job message.
 - Source Value:** The instantaneous value of the source at trigger time.
 - Source Alarm Data:** Details (see table 4.3.7) of the source alarm at message trigger time.

Alarm Type	Embedded details
Absolute	Enable, Type (high or low), Threshold, Status
Deviation	Enable, Type (in or out), Reference, Deviation, Status
Rate of change	Enable, Type (rise or fall), Amount, Change time, Status

Table 4.3.7 Alarm details versus alarm type

Note: If any of 'Source Descriptor', 'Source Value' or 'Source Alarm Data' are embedded in a message which is triggered by a job which cannot be associated with a specific source (e.g. event, timer), then the embedded value will be: ?????.

(Continued)

4.3.7 MESSAGES (Cont.)

Replace {n} with (Cont.)

Specified Descriptor, Specified Value, Specified Alarm data: Produces a further field '{n} source', described below.

Instrument Name: Allows the Instrument Name (as entered in Configuration/Instrument - [section 4.3.1](#)) to be included in the message.

Instrument Number: Causes the instrument number (Network/Address - [Section 4.5.1](#)) to be embedded.

Config Revision: Embeds the Config File Version number (System/About - [section 4.6.5](#)) in the message

{n} source

This field appears only if the previous field (Replace {n} with) is selected as 'Specified Descriptor', 'Specified Value' or 'Specified alarm data'. The associated picklist(s) allow a specific point, and a specific alarm (if appropriate) to be selected. It is thus possible to configure, say alarm 1 on channel 2, to produce a message giving the descriptor and/or value of, say, totaliser 1.

Notes:

1. n = 1 to 9
 2. The example below is intended to clarify message entry techniques.
-

4.3.7 MESSAGES (Cont.)

EXAMPLE

To configure Message 2 to read “The value of Chan two = (*Value channel 2*) & Tot one = (*Value totaliser 1*)”

Before configuring the message:

In channel configuration:

Set channel 2 descriptor to: Chan two
Set Channel 2 alarm job to:
 Category: Message
Send message(s) to: All Groups
 First message: 2) Message 2
 Last Message: 2) Message 2
 On: Active

In Totaliser configuration:

Set Totaliser 1 descriptor to: Tot one

In Messages configuration:

1. Select Message 2.
2. Access the Symbols keyboard (section 3.3.1) and enter, without spaces, { } = { } & { } = { }
3. Access the Numeric keyboard and insert 1, 2, 3, 4 within the braces to give: { 1 } = { 2 } & { 3 } = { 4 }
4. Access the Alphabet keyboard, and insert text and spaces: The value of { 1 } = { 2 } & { 3 } = { 4 }
5. Set ‘Replace {1}’ to ‘Source Descriptor’
6. Set ‘Replace {2}’ to ‘Source Value’
7. Set ‘Replace {3}’ to ‘Specified Descriptor’
8. Set ‘{3} source’ to Tot one
9. Set ‘Replace {4}’ to ‘Specified Value’
10. Set ‘{4} source’ to ‘Tot one’

The result of this is that, should the channel 2 alarm go active, the following message would be sent to all groups, appear on the ‘chart’ and become part of all groups’ histories:

```
18/10/01 11:19:58 The value of Chan two = 6.0°C & Tot one = 3383.8073 Units
```

Note: On some models, the message may be wider than the screen. If necessary, the message can be shortened (e.g. use 'Ch2' instead of 'Chan two'), or it can be viewed in full, either in [Message log](#), (section 3.2.1) or by using Review Software, if available.

4.3.8 User Linearisation Tables

The Channel configuration item 'Lin Type' includes four linearisation tables called, initially, UserLin1 to UserLin4. This User Linearisation part of the instrument configuration allows the user to enter a linearisation look-up table of between two and 66 pairs of points.

The pairs of points are entered as X1Y1, X2Y2... ..XnYn,

where 'n' is the specified number of points.

X1 to Xn represent the inputs to the function.

Y1 to Yn represent the corresponding outputs from the function.

Notes:

1. Each Y value must be unique - i.e. there cannot be more than one X value with the same Y value assigned to it.
 2. Each X value (other than the first) must be greater than the previous one
 3. Each Y value (other than the first) must be greater than the previous one
 4. To specify units other than temperature units, the channel 'scale' facility must be used. The Scale low/high values should be set to match the range low/high values, and the required units string entered .
-

The import/export Linearisation tables feature described in 'Save/Restore' ([section 4.2](#)) offers an alternative way of entering linearisation tables.

Figure 4.3.8a shows the default configuration page. Figure 4.3.8b shows a simple table for relating water depth to water volume for a cylindrical tank with a conical bottom.

Figure 4.3.8a User linearisation configuration page

CONFIGURATION PARAMETERS

User Linearisation	Allows one of the four user linearisation tables to be selected for configuration.
Descriptor	Allows the user to enter a name of up to 20 characters (including spaces) for the table.
Format	This allows the point pair values to be entered as normal numeric values (Numeric) or in 'Scientific' format (Scientific). When 'Scientific' is selected, values are displayed and entered as a decimal number between 1 and 10 [†] (the mantissa), followed by a multiplier (the exponent). E.G. to enter a value of 1244.5678, the value entered would be 1.2445678E3, where 3 represents the number of places that the decimal point must be shifted <u>to the left</u> in order to convert the value to a number between 1 and 10 [†] . To enter a value of 0.0004196, the entry would be 4.196E-4. Figure 4.3.8b, below, gives further examples.

† Notes

1. Strictly this is a number less than 10, as 10 would be 1.0E1.
 2. There must be at least one number after the decimal point.
-

4.3.8 USER LINEARISATION TABLES (Cont.)

Number of points This is used to enter the total number of point pairs in the table. The following XY fields increase in number up to the entered value. (A scroll bar appears if there are more points than can be displayed in the available screen height.)

X1 to XN The input values to the table, where N is the 'Number of Points' entered above.

Y1 to YN The resulting, corresponding output values from the look-up table.

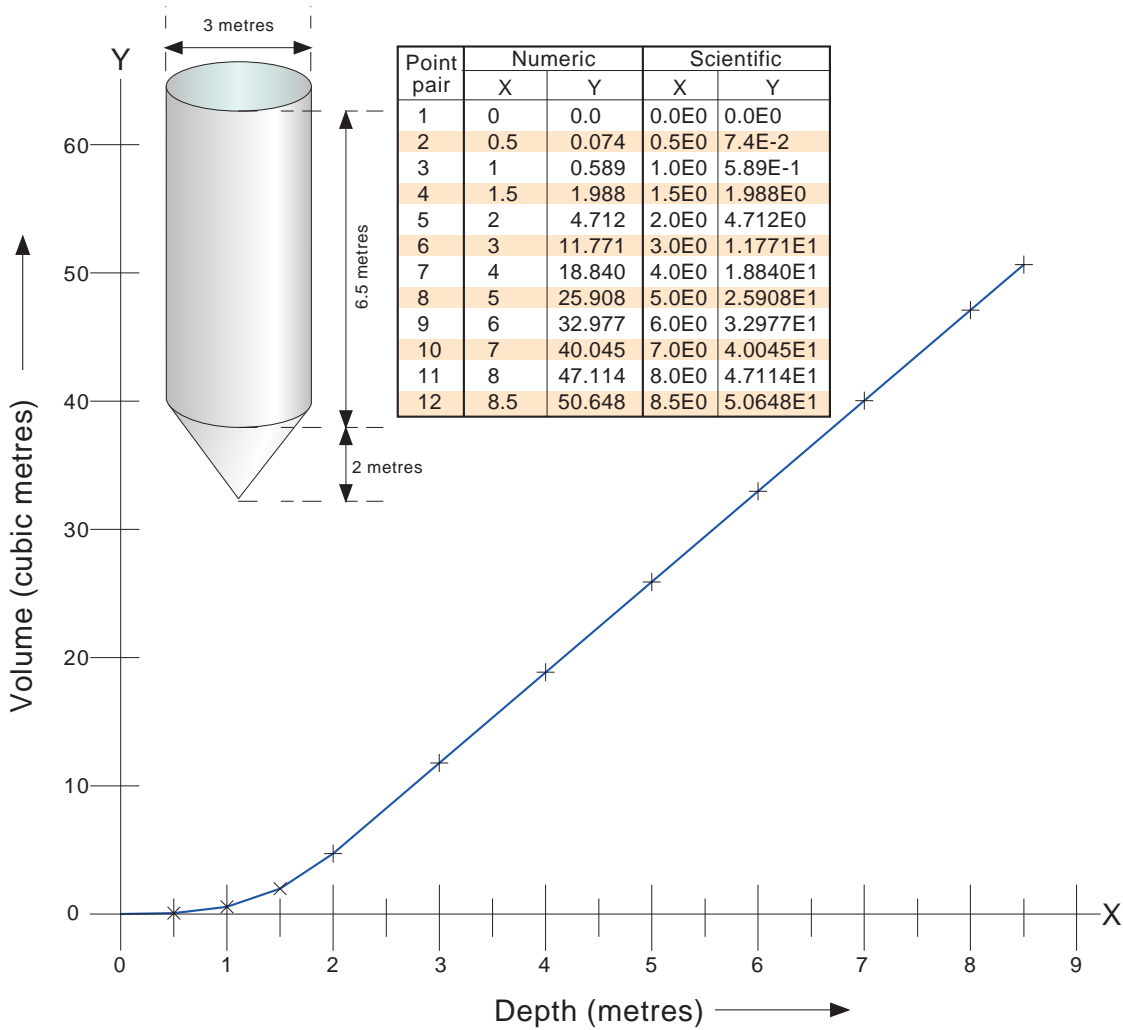

Figure 4.3.8b Sample User Linearisation table

4.3.9 Options

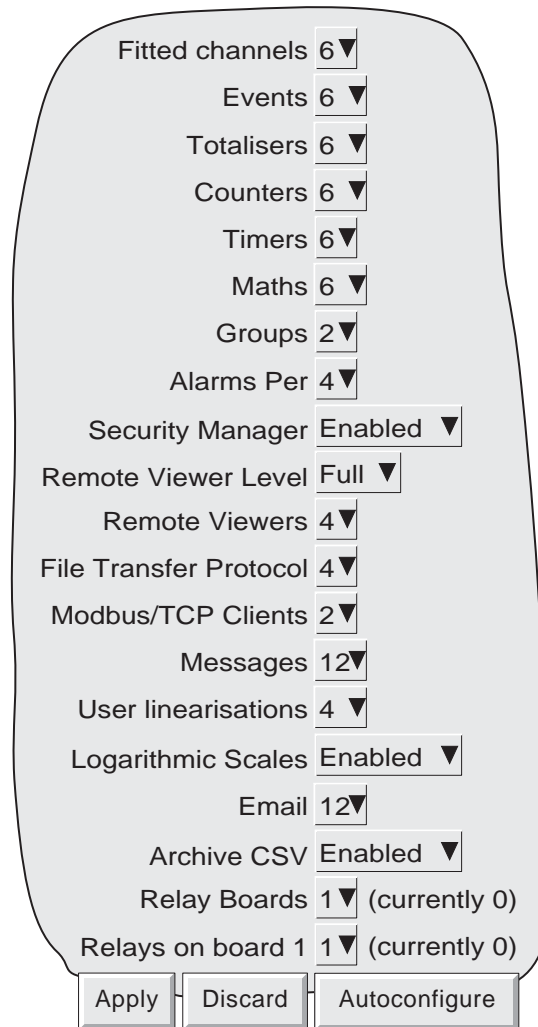

Figure 4.3.9 Options menu layout

Touching this key calls a display showing the current recorder hardware/software setup, for example the number of input channels fitted, whether or not an Ethernet/Relay output board is fitted. This page shows any differences between the hardware actually fitted and the hardware the recorder software is configured for (currently ...). Whenever there is a difference, the 'Autoconfigure' key can be pressed to alert the recorder to the fact that an option has been added (or removed).

If no changes have occurred since last switch-on, then the '(currently ...)' fields and the 'Autoconfigure' key do not appear.

4.4 SECURITY

Touching this key allows the operator to select 'Login' (described in [section 3.3.1](#)) 'Access' or 'Add/Remove User' for configuration. Selecting 'Access' displays the current user level. Touching this area allows the user to select 'Logged out', 'Operator', 'Engineer' or any added users. The user may also go directly to logged out mode by operating the 'Logout' key.

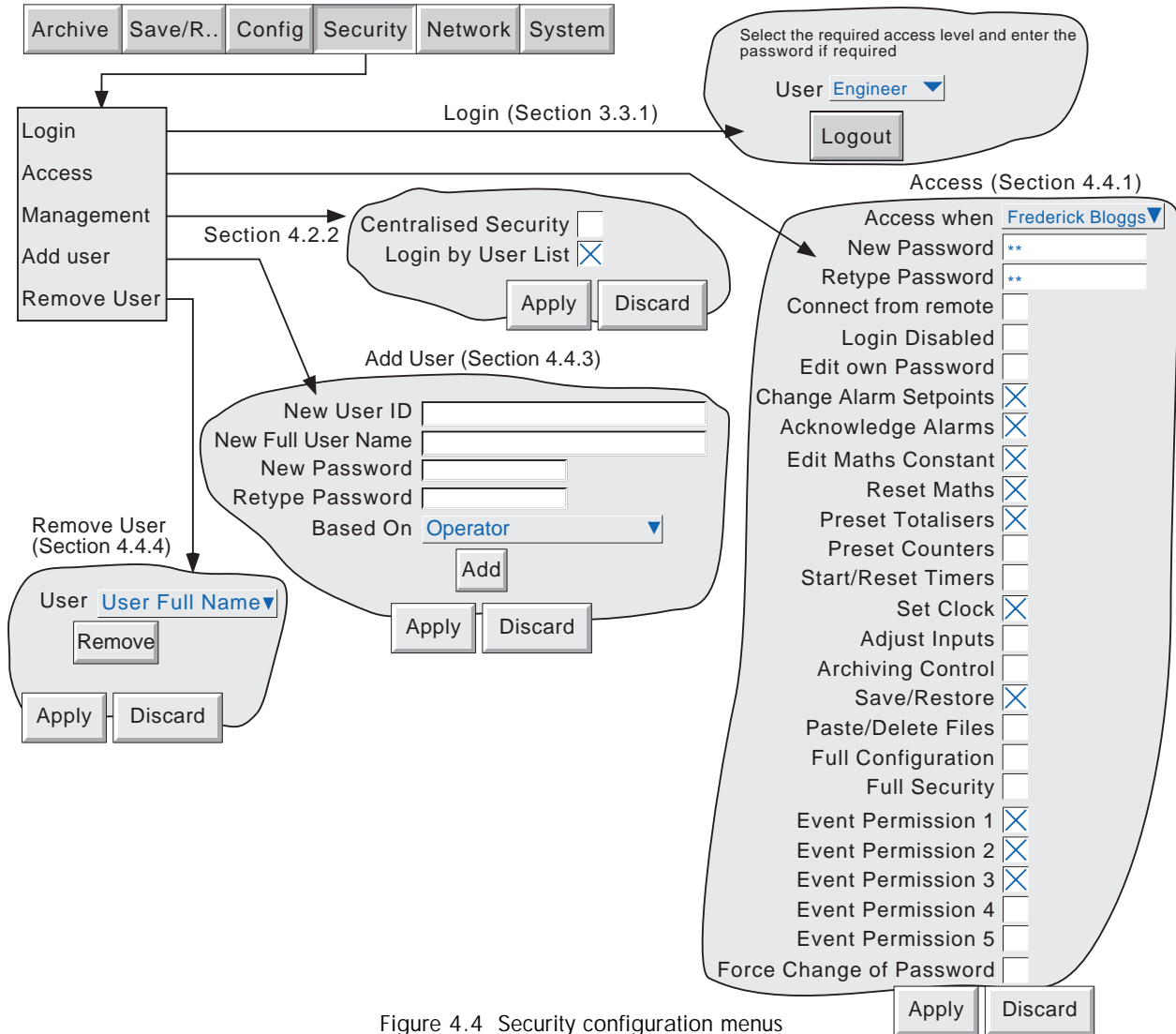

Figure 4.4 Security configuration menus

4.4.1 Access levels

There are essentially three levels of security associated with the recorder viz: Engineer, Operator and Logged out. (The fourth level - Service - is available only to service engineers). When logged-in at engineer level, the user can set access permissions for Operator and logged-out levels, and can edit Operator and Engineer level passwords. The password for both Engineer and Operator levels is set to 10 at the factory.

Note: Setting the password to 'blank' allows subsequent access without a password having to be entered.

Users with Full Security permission can Add (and Delete) users (sections [4.4.3](#), [4.4.4](#)) and assign them individual passwords and access permissions. User names (IDs) appear in the 'Login' and 'Access When' picklists.

4.4.1 ACCESS LEVELS (Cont.)

SETTING PERMISSIONS

Once logged in at Engineer level, operate the 'Security' key and select 'Access'. A page similar to that shown in figure 4.4.1 appears, allowing the permissions to be set for the various access level and for individual users. The list of parameters is the same for all access levels except for 'Logged out', for which the password parameters and 'login disabled' items do not appear.

The screenshot shows a list of permissions with checkboxes and input fields. The 'Access when' dropdown is set to 'Frederick Bloggs'. The 'New Password' and 'Retype Password' fields are disabled (indicated by double asterisks). The 'Connect from remote' checkbox is checked. The 'Remote user name' and 'Remote password' fields are visible. The 'Login Disabled' checkbox is checked. The 'Edit Own Password' checkbox is checked. The 'Change Alarm Setpoints', 'Acknowledge Alarms', 'Edit Maths Constant', 'Reset Maths', 'Preset Totalisers', 'Preset Counters', 'Start/Reset Timers', 'Set Clock', 'Adjust Inputs', 'Archiving Control', 'Save/Restore', 'Paste/Delete Files', 'Full Configuration', 'Full Security', 'Event Permission 1-5', and 'Force Change of Password' checkboxes are all checked. The 'Apply' and 'Discard' buttons are at the bottom.

Callouts in the image:

- Arrow pointing to 'New Password' and 'Retype Password': Password functions do not appear for 'Logged-out' level of access.
- Arrow pointing to 'Remote user name' and 'Remote password': Remote user fields appear only if 'Connect from remote' is enabled.
- Arrow pointing to 'Login Disabled' and 'Edit Own Password': Password functions do not appear for 'Logged-out' level of access.
- Arrow pointing to 'Change Alarm Setpoints', 'Acknowledge Alarms', 'Edit Maths Constant', 'Reset Maths', 'Preset Totalisers', 'Preset Counters', 'Start/Reset Timers': These fields appear only if the relevant options are fitted.

Note: If the Security management option is fitted, and 'Centralised Security' is enabled in the Security/Management system (section 4.4.2), permissions are 'Read Only' (i.e. not editable) at the recorder. In such a case permissions can be changed only by using the Security Management software.

Figure 4.4.1 Access permissions menu

ACCESS WHEN:

Allows an access level or an individual user ID to be selected from a pick list.

NEW PASSWORD/RETYPE PASSWORD

For all levels except Logged Out, these fields allow a new password to be entered for the selected access level or User. The password must be entered in the 'Re-type Password' field. If the two differ, a warning message (Passwords did not match) appears when the APPLY key is operated, and password entry must be repeated.

CONNECT FROM REMOTE

Enabling this field, calls the Remote user name and Remote user password entry boxes.

Note: For maximum security, it is recommended that the remote password and the 'local' password are non identical.

4.4.1 ACCESS LEVELS (Cont.)

REMOTE USER NAME/PASSWORD

These two entry boxes allow user name and password to be entered for use by the remote host operator. The remote user will be able to access the recorder configuration according to the other access permissions enabled in this page. The password must be entered twice to ensure integrity.

To allow unrestricted view-only to the host, 'Logged out' permission level should be selected and then a user name of 'anonymous' entered, and the password field left blank.

Note: Remote login will be refused if the user account is disabled for any reason.

LOGIN DISABLED

For all levels except Logged Out, this allows any one or more of the access levels do be removed from the 'Access when' picklist.

Note: This feature should be used with discretion, or the situation might arise in which the recorder cannot be logged onto, either at a particular access level or at all. It is recommended that at least one user with Engineer-level access is retained with login enabled, or it may become necessary to return the recorder to the manufacturer, or to arrange for a service visit.

EDIT OWN PASSWORD

Allows each user, with this permission enabled, to edit his/her password.

CHANGE ALARM SETPOINTS

Allows each user with this permission enabled, to edit alarm parameters under Configuration/Channel

ACKNOWLEDGE ALARMS

Allows each user with this permission enabled, to acknowledge alarms ([section 3.1.3](#))

EDIT MATHS CONSTANT

This field appears only for recorders with the Maths option.

If one or more maths channels are configured with function 'Constant', then with this permission set, the user may edit the constant value(s). See section 3 of the Options Manual for further details

PRESET TOTALISERS

This field appears only for recorders with the Totaliser option.

Enabling this function allows the user to preset the totaliser value. See section 4 of the Options Manual for further details.

PRESET COUNTERS

Allows the user to preset counter values (if the option is fitted) either directly, from the configuration page, or by setting a counter job. See Section 5 of the Options manual for further details of counters.

START/RESET TIMERS

Allows the user to start and reset the timer value (if the option is fitted) either directly from the configuration page or by setting a timer job. See Section 6 of the Options manual for further details of timers.

SET CLOCK

Allows each user, with this permission enabled, to set the recorder time and date functions under System/Clock

4.4.1 ACCESS LEVELS (Cont.)

ADJUST INPUTS

Allows the user to adjust recorder readings, as described in section 4.6.4, below.

ARCHIVING CONTROL

Allows each user, with this permission enabled, full access to disk archive control.

SAVE/RESTORE

Allows each user, with this permission enabled, full access to saving and restoring functions as described in [section 4.2](#), above. Without this permission, the SAVE/RESTORE key does not appear.

PASTE/DELETE FILES

Allows each user, with this permission enabled, to Paste and delete files as described in section 5 of this manual.

FULL CONFIGURATION

Allows each, user with this permission enabled, full access the recorder configuration.

FULL SECURITY

Allows each user, with this permission enabled, full access to all recorder security functions.

EVENT PERMISSION 1

If this is enabled, then this login will trigger an event source which remains active for as long as the login is active. See [section 4.3.6](#) (Event Sources: User Logged In) for further details.

EVENT PERMISSION 2 TO 5

As for Event permission 1, above.

FORCE CHANGE OF PASSWORD

When this checkbox is enabled for a user, it means that that user will have to change password at his/her next login. At next log in, a pop-up dialogue box requests that a new password be entered. If a new password is not entered, login is denied.

Entering the new password clears the checkbox, so this is a 'one-shot' operation, until the checkbox is enabled again by a user with 'Engineer' level access.

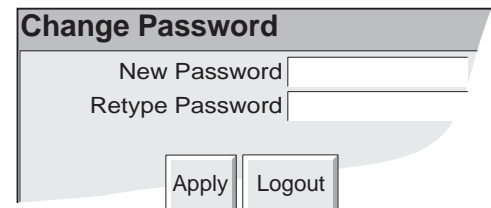

The image shows a 'Change Password' dialog box. It has a title bar with the text 'Change Password'. Below the title bar, there are two text input fields: 'New Password' and 'Retype Password'. At the bottom of the dialog box, there are two buttons: 'Apply' and 'Logout'.

4.4.2 Management (option)

This menu selection appears only if the Security Management option is fitted.

Centralised security If this checkbox is enabled, the following parameters can no longer be edited at the recorder. Changes to these parameters can be made only by means of Security Management software:

Security\Access: All parameters become 'Read only' ([Section 4.4.1](#))
 Security\Management: Login by User List (below) becomes 'Read only'.
 Security\Add User ([section 4.4.3](#)) no longer appears as a menu item.
 Security\Remove User ([section 4.4.4](#)) no longer appears as a menu item.
 Save/Restore\Restore: Security Data not selectable ([section 4.2.2](#))
 Save/Restore\New: Security Data not selectable ([section 4.2.3](#))

The Security Revision (previously Security Version) is initially set to -1 when Centralised Security is enabled. It will remain at this value until a successful download has been performed via Security Manager Software. The Security Revision will then take the downloaded value (e.g. 139). Any local security revision changes (e.g. max. number of logins exceeded) cause the value to have a 'local change count', starting at 001 appended to it (e.g. 139.001, 139.002 and so on). The local change count is reset to 000 (and no longer displayed) when the next download occurs (e.g. 140). Downloads can occur automatically when the Security Manager detects that a local change has occurred, or manually, as and when required.

Login by User List Enabled: At login time the normal login window appears, with a pull-down list of users and access levels. Once a user or access level has been selected from this picklist, the relevant password must be entered to allow access to recorder configuration.
 Disabled: the user must enter both a user ID and the password associated with this ID.

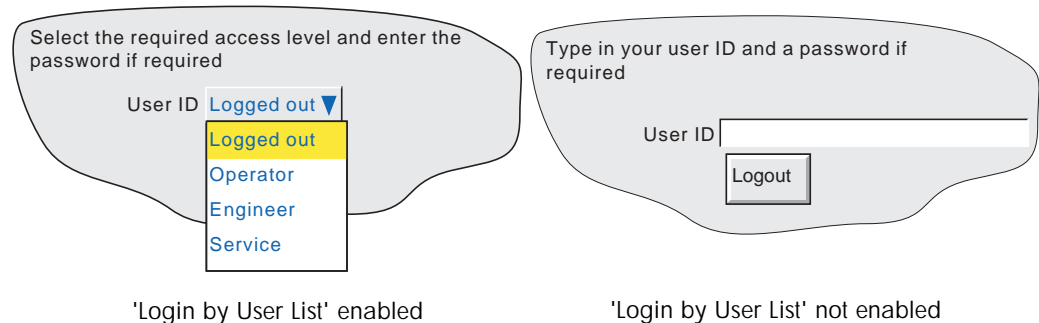

4.4.3 Add user

Figure 4.4.3 shows that the selecting of 'Add User' from the SECURITY picklist allows new users to be entered, together with passwords, and a chosen set of access permissions, which can subsequently be edited under Security/Access. The ADD key and the APPLY key must both be used to write the change to the recorder data base. The user must have Full Security access in order to add a new user.

NEW USER ID

This field allows a User ID of up to 20 characters to be entered for a new user. This ID is used when logging in using ID/password entry technique (that is, when 'Login by user list' is disabled, as described in section 4.4.2 above).

NEW FULL USER NAME

This field allows a User name of up to 25 characters to be entered. This name appears in the 'current access level' pushbutton at the top left corner of the display screen, in operator notes and so on.

NEW PASSWORD/RETYPE PASSWORD

These fields allow a password to be entered and confirmed. If the password does not comply with the minimum length requirements in Security Management (if fitted) (section 4.4.2), a warning message (Invalid Password) appears when the 'Apply' key is operated, and password entry must be repeated.

BASED ON

This picklist allows another user or access level to be used as a permissions template, to simplify the configuration if several operators are to have identical permissions.

Figure 4.4.3 Add User display page

4.4.4 Remove user

This item appears only if one or more users have previously been added.

Selecting 'Remove User' from the SECURITY picklist allows users to be removed from the user list. The 'Remove' key and the 'Apply' key must both be used to write the change to the recorder data base. Figure 4.4.4 depicts the display page.

Figure 4.4.4 Remove User display page

4.5 NETWORK CONFIGURATION

Notes

1. The Network key appears only if the Ethernet option is fitted
2. This manual does not describe network setup in detail, as each network is different. In many cases, the help of the network administrator or supervisor will be required, for example, in the allocation of valid addresses and passwords.

Operating the Network key calls a selection box to the display, allowing 'Address' or 'Name' to be selected for configuration.

4.5.1 Address

Figure 4.5.1 shows the address menu fields.

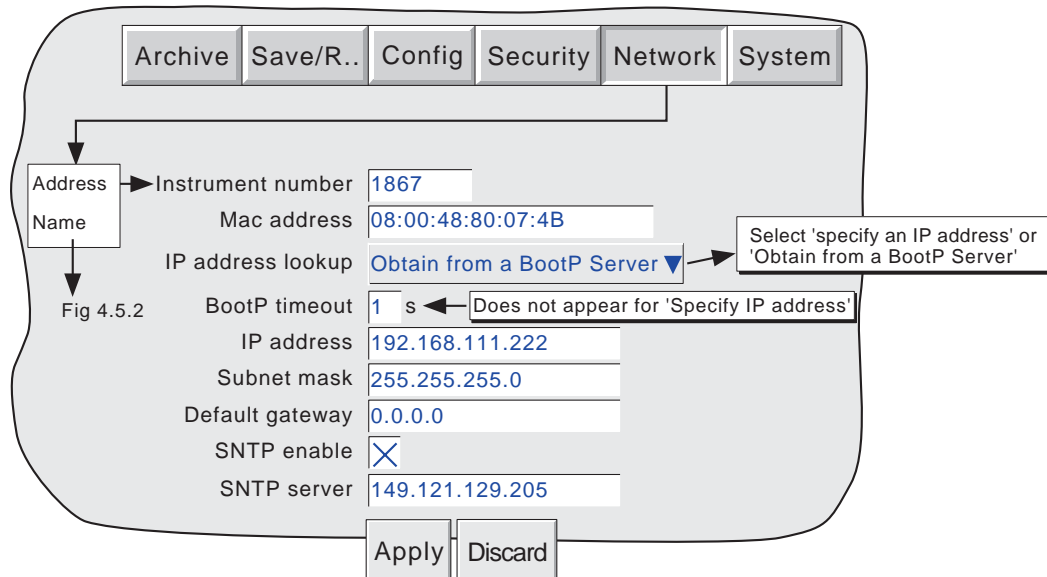

Figure 4.5.1 Network addressing

INSTRUMENT NUMBER/MAC ADDRESS

Unique numbers set up during manufacture to identify the recorder to a remote host, or to the recorder manufacturer/distributor, in case of query.

IP ADDRESS LOOKUP

This field allows an address to be entered for the recorder. This can be done either by manually entering an address (IP address field - below), or the network service BootP can be used to assign an IP address to the recorder.

BOOTP TIMEOUT

This is the maximum time the recorder will wait, at power-up, for a response from the BootP server. If no response is received within this time, the IP address, Subnet mask and Default gateway are all set to, or remain at 0.0.0.0

IP ADDRESS

Allows manual entry of the recorder's internet protocol (IP) address only if 'Specify an IP address' is selected in the 'IP address lookup' picklist above.

4.5.1 NETWORK ADDRESS (Cont.)

SUBNET MASK

This field is editable only if 'Specify an IP address' is selected in the 'IP address lookup' picklist above. The subnet mask is the network address plus the bits in the host address reserved for sub-network identification. By convention, all the network address bits are set to 1. The subnet mask is used to identify the subnet to which an IP address belongs by performing a bitwise AND on the mask and the IP address.

DEFAULT GATEWAY

To deliver traffic from one subnet to another, devices called 'routers' or 'gateways' are placed between segments. The default gateway address informs each network device where to send data if the target station does not reside on the same subnet as the source.

SNTP ENABLE

This tick box allows time synchronisation from a Simple Network Time Protocol (SNTP) server to be enabled and disabled. When enabled, the instrument time is checked every 15 minutes and updated if necessary (see also notes below).

SNTP SERVER

If 'Obtain from BootP server' is selected as the IP address look-up (see above), then this SNTP address appears automatically. Otherwise this area allows an IP address to be entered for the SNTP server.

SNTP Notes:

- 1 SNTP is a protocol that allows clients on a TCP/IP network to set their times to that of a server - port number 123. The recorder can act both as a client and as a server; when acting as a server, the resolution is 1 msec.
 2. SNTP time is based on elapsed seconds since 00:00 hrs on 1st January 1900. The time is not affected by time zones or daylight saving adjustments.
 3. If the instrument time differs from the SNTP time by less than 2 seconds, the instrument time is updated gradually (1 msec 8 times a second) to prevent time change events being recorded. If the difference is greater than 2 seconds, this is defined as a 'time change event', the results of which are that the recorder time is immediately updated, and a green line is drawn across the chart (vertical trend/history only) to indicate the time change.
 4. If more than 5 time change events occur within 24 hours, a 'Time Synchronisation failure' instrument alarm is set 24 hours after the first event. Once synchronisation is re-established, the alarm self clears within 24 hours.
 5. An 'SNTP server failure' instrument alarm is flagged if the configured server cannot be accessed, or if the year received from the server is less than 2001 or more than 2035.
 6. When the instrument is acting as a server and a 'Clock Failure' instrument alarm is active, the server time is set to 1/1/1900 which is ignored by clients.
 7. For more information on SNTP, the following site may be contacted:
<http://mirror.ox.ac.uk/Mirrors/www.ietf.org/rfc/rfc1769.txt>
-

It is also possible to synchronise a number of recorders with one another by using the Preset clock Job to set the time to that entered in Instrument Configuration. [Section 4.7.6](#) gives more details

4.5.2 Name

Figure 4.5.2 shows the 'Name' fields

The screenshot shows a network configuration window. At the top, there is a menu bar with buttons for 'Archive', 'Save/R..', 'Config', 'Security', 'Network', and 'System'. The 'Network' menu is open, and a sub-menu is visible with 'Address' and 'Name' options. The 'Name' option is selected, and an arrow points to the configuration fields. The fields are: 'Local Host' with the value 'Andy136-4', 'Domain' with the value 'FishesRus.co.uk', 'Domain Name Service' with a checked checkbox, 'Primary DNS Server' with the value '149.121.164.11', and 'Secondary DNS Server' with the value '149.121.165.14'. At the bottom of the window, there are 'Apply' and 'Discard' buttons.

Figure 4.5.2 network name fields

LOCAL HOST

English language name for the recorder - Assigned to the IP Address

DOMAIN

The name of the Group or area of networked units which contains the recorder

DOMAIN NAME SERVICE (DNS)

Enables the mapping of host names to IP addresses and *vice-versa*.

PRIMARY/SECONDARY DNS SERVER

IP addresses supplied by IT department or the Domain manager or Supervisor.

Note: Any one or more of the above items may be overwritten if 'IP address lookup' is set to 'Obtain from BootP Server' as described under 'Address' above.

4.6 SYSTEM

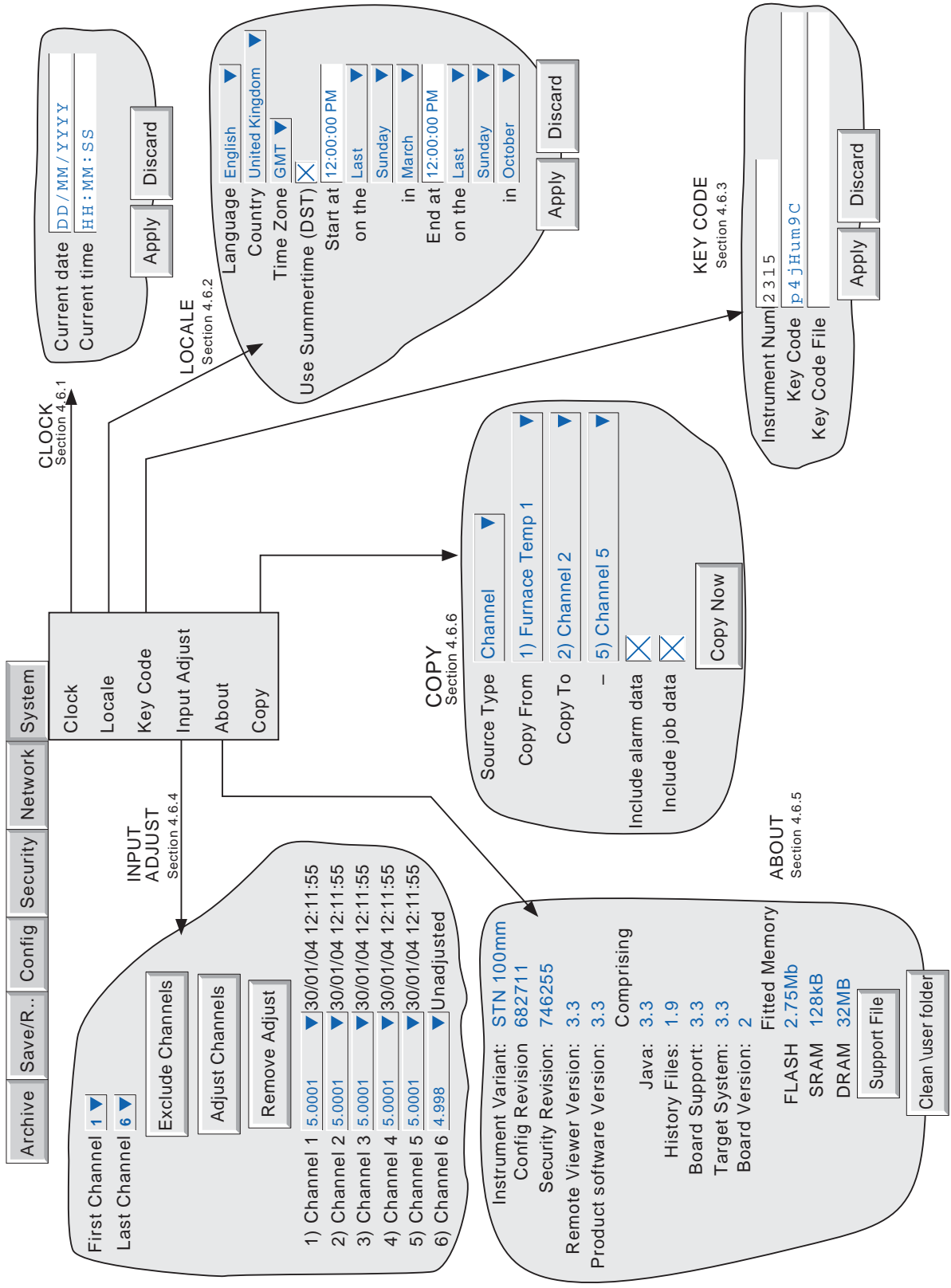

Figure 4.6 System configuration menu layout

4.6 SYSTEM (Cont.)

Touching the System key calls the pick list: Clock, Locale, Keycode, Input Adjust, About

Figure 4.6 above, shows an overview of the System Menus.

4.6.1 Clock

Selecting 'clock' causes the recorder's date and time to be displayed. To edit the date, touch the current date area, to call the keyboard and enter the new numbers. The date is edited in a similar way. The settings apply as soon as the 'Apply settings' button is touched. See also SNTP details in [section 4.5.1](#).

4.6.2 Locale

This allows the setting of the following items:

Language	Choose the required language from the picklist
Country	Displays a pick list of countries associated with the selected language
Time zone*	Select GMT, UTC, ECT, EET, ART, EAT, MET, NET, PLT, IST, BST, VST, CTT, JST, ACT, AET, SST, NST, MIT, HST, AST, PST, PNT, MST, CST, EST, IET, PRT, CNT, AGT, BET, CAT from picklist.
Use Summertime (DST)*	Select box if daylight saving is to be used, If 'Use Summertime (DST)' is selected, the times and dates for the start and end of summertime can be entered using picklists - see figure 4.6

Notes:

1. Date format DD/MM/YY or MM/DD/YY is defined by the language and country selected. Time format (e.g. 12/24 hr clock) is defined by the country selected.
 2. When using Remote Viewer, the host PC's locale information and the recorder locale information should match, or the displayed time will not be correct.
-

*Note: For more information, see section B7 (Annex B), and/or <http://www.timeanddate.com>

4.6.3 Keycode

This is a means of allowing new options to be enabled, by the entering of a code, using standard text entry techniques, or by reading a file from a floppy disk. If a File is specified, the first line of the file must be the Key Code. To select the file for reading, the Key Code File field is touched, to display the file list - if necessary, refer to section 5, below, for more details

The Instrument Number, which must be quoted if ordering upgrades, is unique to the instrument and is not user editable.

4.6.4 Input adjust

This facility allows the user to compensate for tolerance errors etc. The technique used is to select those channels to which adjust is to be applied, then for each channel:

- a. apply a known low level signal (at or close to the low input range value) to the relevant input. When the recorder reading is steady, press 'Apply'.
- b. apply a known high level signal (at, or close to, the high input range value) to the relevant input. When the recorder reading is steady, press 'Apply'.

Note: Input adjust cannot be applied to input channels with input type of 'Digital', 'Test' or 'comms'.

4.6.4 INPUT ADJUST (Cont.)

Figure 4.6.4a shows the initial display which appears when 'Input adjust' is first selected from the SYSTEM menu. Channels 1 to 6 are selected by default.

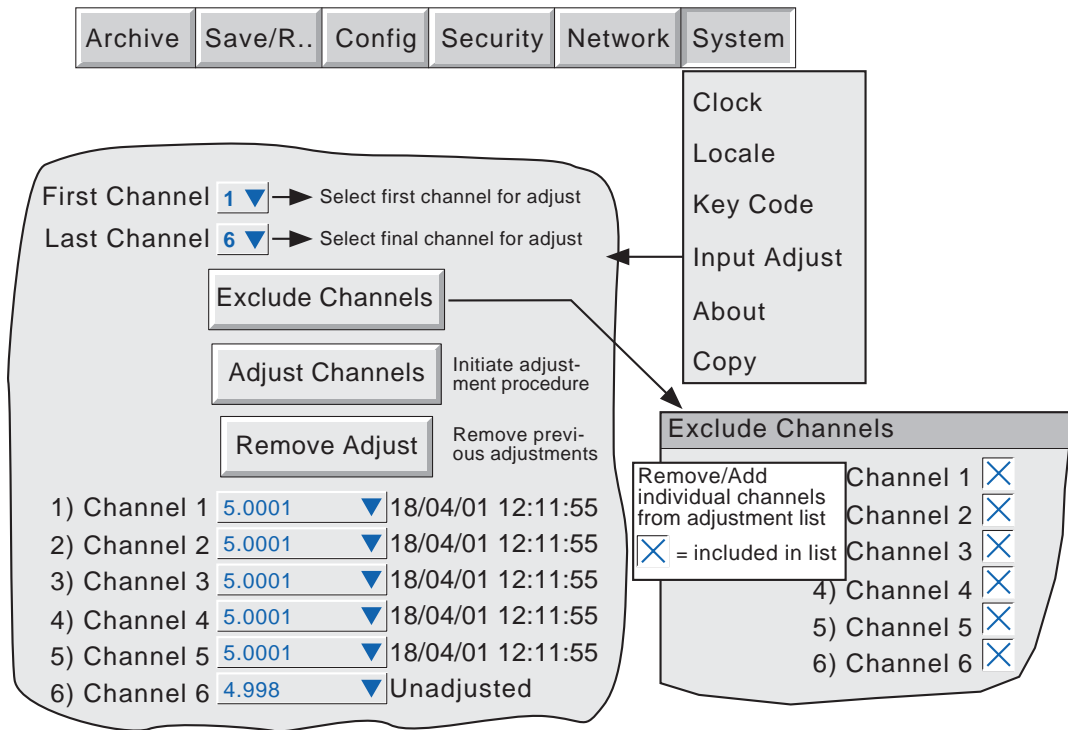

Figure 4.6.4a Input adjust status page

First channel	Allows the user to select the lowest channel number of all the channels to be adjusted.
Last channel	Allows the user to select the highest channel number of all the channels to be adjusted.
Exclude Channels	Presents a list of all the channels from the First channel to the Last channel inclusive, each of which can be removed from the list by 'unchecking' its check box. The channels displayed in the status page reflect this selection.
Adjust channels	Initiates the adjustment procedure to all the channels from the First channel to the Last channel inclusive, unless the effectivity is modified using the Select Channels key.
Remove Adjust	Returns the selected channels to factory calibration
1) Channel 1 etc.	A list of channels required to be susceptible to the adjustment procedure, together with their current values and their adjustment status (i.e. Unadjusted or, the time/date of the previous adjustment (if any)).

4.6.4 INPUT ADJUST (Cont.)

ADJUST PROCEDURE

Operation of the Adjust Channels key calls the low-end adjust page, as shown in figure 4.6.4b.

Archive Save/R.. Config Security Network System

Specify the sensor low point and connect the corresponding input.

Low Point

When the values below have settled select Apply.

1) Channel 1	<input type="text" value="-0.0026"/>	Unadjusted
2) Channel 2	<input type="text" value="-0.0001"/>	Unadjusted
3) Channel 3	<input type="text" value="-0.0002"/>	Unadjusted
4) Channel 4	<input type="text" value="-0.0002"/>	Unadjusted
5) Channel 5	<input type="text" value="0.0000"/>	Unadjusted
6) Channel 6	<input type="text" value="0.0000"/>	Unadjusted

Apply Discard

Figure 4.6.4b Typical low-end input adjust page

Low Point Usually 0, but a different value can be entered here, if required.

Apply the Low point value to the relevant input channels, and wait some minutes for the recorder readings to become stable. When the readings are stable, press the Apply key, to call the High-end page depicted in figure 4.6.4c, below.

Archive Save/R.. Config Security Network System

Specify the sensor low point and connect the corresponding input.

High Point

When the values below have settled select Apply.

1) Channel 1	<input type="text" value="4.9993"/>	Unadjusted
2) Channel 2	<input type="text" value="4.9972"/>	Unadjusted
3) Channel 3	<input type="text" value="5.0010"/>	Unadjusted
4) Channel 4	<input type="text" value="4.9994"/>	Unadjusted
5) Channel 5	<input type="text" value="5.008"/>	Unadjusted
6) Channel 6	<input type="text" value="5.011"/>	Unadjusted

Apply Discard

Figure 4.6.4c Typical high-end input adjust page

High Point Default value displayed, but a different value can be entered here, if required.

Apply the High point value to the relevant input channels, and wait some minutes for the recorder readings to become stable. When the readings are stable, press the Apply key, to return to the status page.

Note: Adjusting a channel invalidates the accuracy values given in the specification in Annex A for that channel.

4.6.5 About

Selecting 'About' gives details of the version numbers of different aspects of the recorder, and details of the amount of memory fitted.

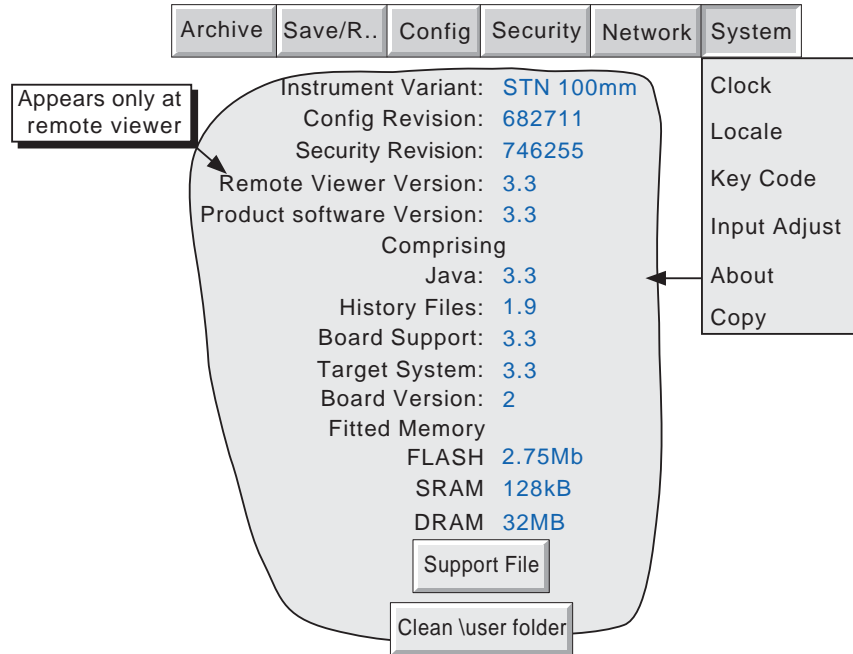

Figure 4.6.5 Access to the 'About' display

INSTRUMENT VARIANT

Displays an instrument type code.

CONFIG REVISION

Whenever a change to the Configuration of the recorder is applied the 'Config revision' is incremented. For these purposes, Configuration is defined as including all items within the menu structures of the Config and Network keys. It does not include those items associated with the Security key. Config revision is printed on the 'chart' at power up. See also notes 1 and 3 below.

SECURITY REVISION

Whenever a change is made to an item within the Security menus, the Security revision is incremented. Security revision is printed on the 'chart' at power up. See notes 1 and 2, below.

Notes:

1. Config revision and/or Security revision can be used as inputs to maths channels. If such a channel is included in one or more groups, the version number can be determined for any time/date when Trend History mode is invoked for the group(s) in question. See the Options Manual for maths option details.
2. If centralised security is enabled, the Security Revision appears in a different format (e.g. 15.001). See [section 4.4.2](#) for details.
3. Config revision can be embedded in one or more messages, as described in [section 4.3.7](#).

4.6.5 ABOUT (Cont.)

SUPPORT FILE

If the unit is not performing as it should (e.g. it resets itself unexpectedly), the Support File key allows the user to save 'critical system files' into a single file (SupportInfo.uhq*) to the instrument's floppy disk/pc card, or to the remote viewer's PC, for despatch to the manufacturer for analysis. For security reasons, this file cannot be viewed by anyone other than the manufacturer or his agents.

Once the save operation is complete, a 'Support' message appears on the screen giving details of where to send the file. More information is held in the file 'SupportInfo.txt' which is also saved to the disk. This file can be opened, and the information within it read, by inserting the disk into a PC, clicking on the floppy disk icon (A drive) in 'My Computer' and then double clicking on the file icon when it appears.

* 'SupportInfo' is the default name. This name may be edited by the user before saving to disk or pc. The .uhq suffix is automatically appended to the new name.

CLEAN \USER FOLDER

Notes:

1. This button appears only for users with 'Full Configuration' access permission.
2. Before carrying out this operation, it is recommended that all required files are saved to disk, or pc card.

Operating this button causes the instrument to delete 'unnecessary' files from the \user folder, and to compress (zip) others such as user screens. Permission is asked before configuration files, user screens etc. are deleted.

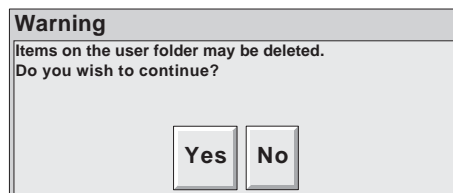

Note: 'Yes to All' applies only to 'remaining' files. It does not delete files for which delete permission has previously been denied by operation of the 'No' button.

Once all deletions are complete, a list of deleted items is displayed.

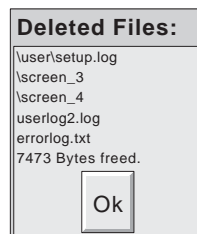

4.6.6 Copy

This facility allows the user to copy a point or group configuration from one point, group etc. to one or more others. The user may choose whether or not to include alarm and (if applicable) job data when copying point configurations. Descriptors and colour selections are not copied.

Figure 4.6.6 shows a typical configuration page for copying the configuration of channel 1 (Furnace Temp1) to channels 2 to 5 inclusive.

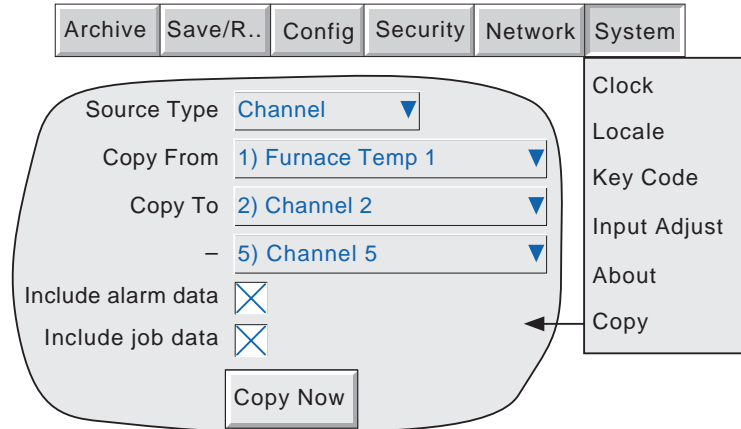
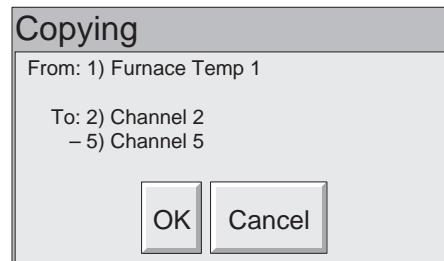

Figure 4.6.6 Copy configuration page (typical)

When 'Copy Now' is operated, a confirmatory dialogue box opens, to allow the user to check the source and destination entries.



CONFIGURABLE PARAMETERS

Source Type	Picklist allows selection of Group, Channel, Event, Message, Maths Channel, Totaliser, Counter or Timer as the type of source to be copied.
Copy From	Allows the user to select a specific point, group etc. to be copied
Copy To	Allows the first destination point to be selected, for the source to be copied to.
-	Allows the final destination point to be selected for the source to be copied to.
Include alarm data	This field appears only for source types which support alarms. If this box is 'selected', then alarm data is included in the copy process.
Include job data	This field appears only for source types which support jobs. If this box is 'selected', then jobs data is included in the copy. For source types that support both alarms and jobs, it is not possible to include job data, without including alarm data as well.

4.6.6 COPY (Cont.)

Once the copy is complete, the user should enter the configuration area of the items that have been copied, and edit/apply the changes etc.

COPY RULES

1. The first channel on any input card may not be a digital input type.
2. If a destination channel was a digital input, AND the source channel is an analogue input AND 'include alarm data' is not selected, the destination channel alarm settings will be set as:
Enable = Off; Type = Absolute high; Threshold = 0.0; Dwell = 0.0.
3. If a destination channel was an analogue input, AND the source channel is a digital input AND 'include alarm data' is not selected, the destination channel alarm settings will be set as:
Enable = Off; Type = Digital; Threshold = Closed; Dwell = 0.0.
4. Descriptors and Colours are never copied.

4.7 JOBS

A number of sources (e.g. channel, event, totaliser) can be set up to trigger one or more jobs. The following descriptions include all possible job categories, but the jobs which are available on any particular recorder depend on the options fitted to that recorder. Many job categories require the relevant access level permission to be set, as described in [section 4.4.1](#), above.

The type of action (continuous or 'single-shot'), available for selection, depends on the type of trigger source. Continuous actions are selected from: Whilst active, Whilst inactive or Whilst unacknowledged. The available single-shot actions are: On becoming active, On becoming inactive, On acknowledgement.

4.7.1 No Action

This means that no job action is configured for the trigger source.

4.7.2 Drive relay

If the Relay/Ethernet option is fitted, this means that the relay changes state when the trigger source becomes active. The relay is normally energised i.e. pin 2 (common) is shorted to pin 3 (normally open). When in alarm, the relay is de-energised i.e. pin 2 (common) is shorted to pin 1 (normally closed). Thus, if power is removed from the recorder, the relay automatically 'fails safe' to its alarm condition. See [figure 2.2.1c](#) for relay pinout.

4.7.3 Totaliser category

If the Totaliser option is fitted (section 4 of the Options Manual), the following jobs become available:

Preset	Loads the selected totaliser with the value set up in 'Preset' in the totaliser's configuration menu.
Preset Group	Loads all the totalisers in the specified group with their 'Preset' values.
Disable	Stops the specified totaliser accumulating.
Disable Group	Stops all totalisers in the specified group.

Note: If more than one job is set up to disable a particular totaliser, then any of these jobs going active will disable the totaliser, unless the software version is prior to version 1.7, in which case, all relevant jobs have to be active simultaneously in order to disable the totaliser.

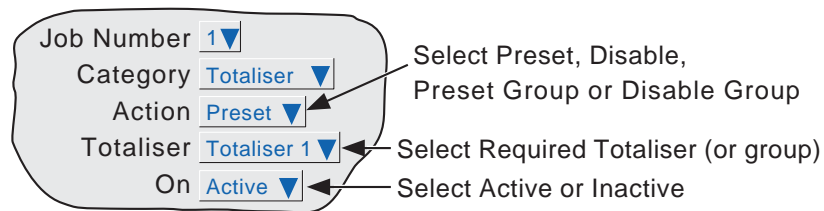

Figure 4.7.3 Totaliser job menu layout

4.7.4 Message category

One or more messages (section 4.3.7), can be directed to the display (where it appears in a pop-up window), to both groups or to a specified group. Messages must be contiguous - e.g. messages 2, 3 and 4 may be sent, but messages 1, 3 and 4 cannot be sent without message 2.

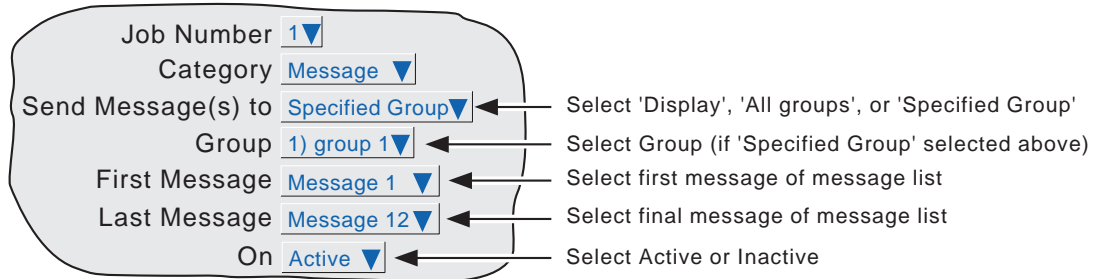

Figure 4.7.4 Message job menu layout

4.7.5 Maths Category

If the Maths option is fitted (section 3 of the Options Manual), the following jobs become available

Reset	Sets the selected maths channel value to zero.
Disable	Stops historical functions such as Fvalue, Stopwatch and Rolling Average from accumulating further values. When the function is subsequently re-enabled, the function re-starts from its pre-disabled value. 'Disable' has no effect on other functions.
Switch to B	Causes the relevant maths channel to copy source B instead of its normal source A - see section 3.1.4 of the Options manual for further details.
Trigger	Used to initiate a 'Sample and hold' function - see section 3.1.4 of the Options manual for further details.

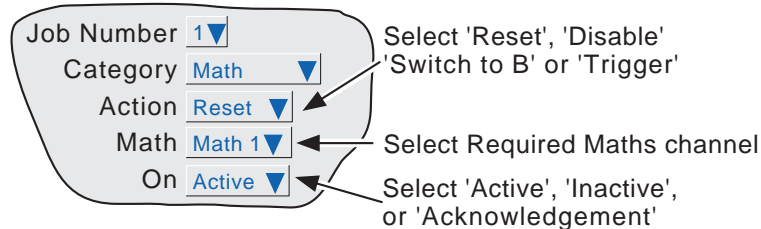

Figure 4.7.5 Maths job menu layout

4.7.6 Clock category

This job causes the System Clock to be Preset to the value entered in Instrument Configuration (Preset Hour, Preset Minute) (Section 4.3.1). This job can be used to synchronise a number of recorders as follows:

- a. For each recorder, set up one input channel as
 - Input Type Digital
 - Closed String Synch (for example)
 - Enable Trigger
 - Active when Synch
 - Job 1 category Clock
 - Job 1 action Preset.
 - Job 1 On Active
- b. For each recorder, set the same preset hour and minute in Instrument Configuration.
- c. For each recorder provide a simultaneous pulse or contact closure to the digital input previously set up.

The recorders will all be automatically set to the preset time on receipt of the input.

An alternative way of synchronising resorders is via an FTP time server (SNTP) as described in section 4.5.1.

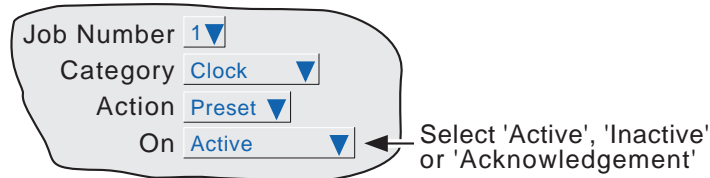

Figure 4.7.6 Clock job menu layout

Note: Whenever a time change occurs, a green line is drawn across the chart in vertical trend mode

4.7.7 Counter category

If the Counter option is fitted (section 5 of the Options Manual), the following jobs become available:

- Preset counter Loads the selected counter with the preset value set in the configuration for that counter.
- Disable counter Stops the selected counter.
- Increment Adds 1 to the selected counter's value.
- Decrement Subtracts 1 from the selected counter's value.
- Preset group Loads all the counters in the specified group with their 'Preset' values.
- Disable group Stops all counters in the specified group.

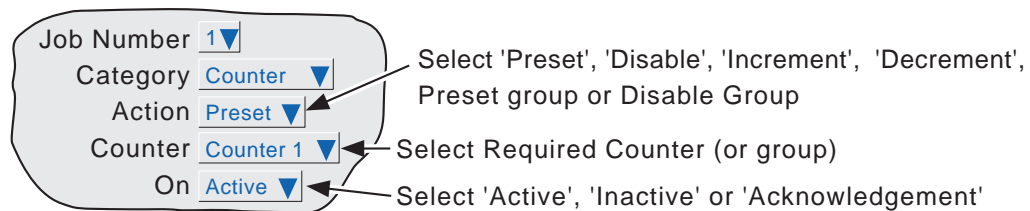

Figure 4.7.7 Counter job menu layout

4.7.8 Timer jobs

If the Timer option is fitted (section 6 of the Options manual), the following jobs become available:

1. Reset timer - sets the timer to zero
2. Start timer - causes the timer to start.
3. Disable timer - stops the timer.

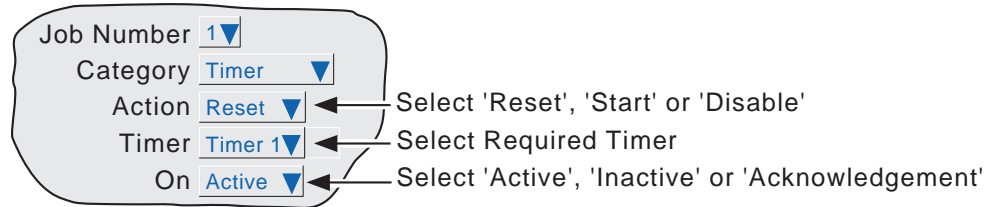

Figure 4.7.8 Timer job menu layout

4.7.9 Recording jobs

A Recording job:

- a) allows the user to record to a specified group's history file, only by job initiation.
- b) allows the recording speed/interval B to be selected for use, for the duration of the job. See 'Group configuration for [A/B switching](#) details.

Notes:

1. The group in question will be recorded only if Recording Enable selected in Group Configuration ([section 4.3.2](#)) and the job is active.
2. A blue line is drawn across the chart whenever a recording job is used to disable/enable recording.

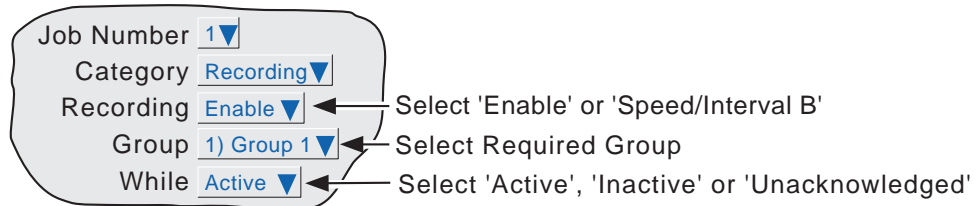

Figure 4.7.9 Recording job menu layout

4.7.10 Trend jobs

Trend jobs allow the following actions to occur:

Span B	Switches the point being configured to span B and zone B, for as long as the job is active.
Span B Group	Switches all the points in the selected group to their individual spans and zones B, for as long as the job is active.
Colour B	Switches the point being configured to colour B, for as long as the job is active.
Colour B Group	Switches all the points in the selected group to their individual colours B, for as long as the job is active.
Speed/Interval B	Switches Trend Speed/Interval for the selected group to Speed/Interval B, for as long as the job is active.

Note: Default B values are the same as the initial default 'A' Values. Thus, if a 'B' value has not been set, the default 'A' value will be used.

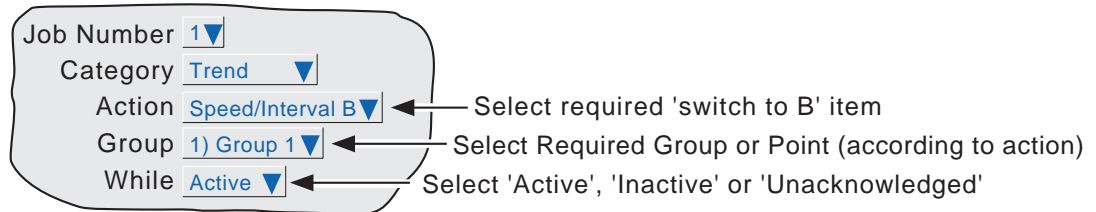

Figure 4.7.10 Trend job menu layout

4.7.11 Alarm jobs

This allows the user to set up a job to acknowledge or disable point alarms as follows:

Acknowledge All Alarms	Acknowledges all alarms
Acknowledge Alarms on Group	Acknowledges all alarms in the specified group
Acknowledge Alarms on Point	Acknowledges all alarms associated with the specified point
Acknowledge Alarm	Acknowledges specific alarm
Disable All Alarms	Disables all alarms
Disable Alarms on Group	Disables all alarms in the specified group
Disable Alarms on Point	Disables all alarms associated with the specified point
Disable Alarm	Disables a specific alarm

Further selection boxes allow a group or point, respectively, to be defined.

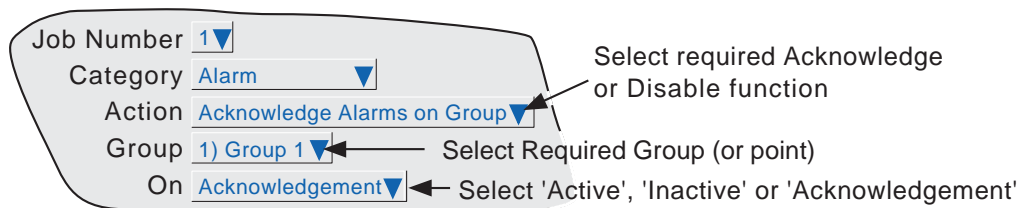

Figure 4.7.11 Alarm job menu layout

4.7.12 Archive jobs

Archive jobs allows a job to be used to trigger an archive to the floppy disk or to a host computer using FTP transfer.

The following jobs are available:

Archive Last Hour, Last Day, Last 7 Days or Last 31 days to FTP

Bring FTP archive up to date

Cancel Archive to FTP

Archive Last Hour, Last Day, Last 7 Days or Last 31 days to Media

Bring Media Archive up to date

Suspend Archive to Media

Cancel Archive to Media

These jobs copy the archiving functions available from the 'Archive' key described in section 4.1 of this document.

For 'FTP' items see [Remote](#); for 'Media' see [Disk](#).

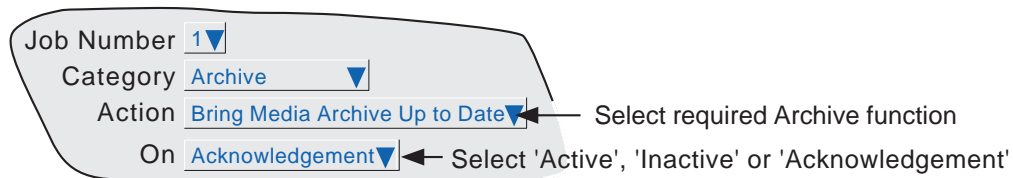

Figure 4.7.12 Archive jobs menu layout

4.7.13 Email category

Allows the user to send a specified e-mail to the recipients set up in e-mail configuration (see options manual). A message is generated, and displayed in all recording groups, whenever an e-mail is sent.

5. FILE

[Figure 5](#), below, gives an overview of the File Menus. The area is entered by touching the 'File' key of the [root](#) menu, and can be used to display the contents of directories stored both in the user area of flash memory and on any disk currently inserted.

The first display page shows the 'volume' or 'device' names associated with the various areas of memory available to the user. If one of these volume names is selected (touched), and the 'open-folder' key operated, the contents of the selected volume is displayed. This would typically consist of a list of folders. Similarly, if a folder name is selected and the 'open folder' key is touched, the contents of the folder is displayed and so on.

To return to higher levels, the 'close-folder' key is used.

The path name of the current window is shown at the top of the window.

5.1 FILER OPTION MENU KEYS

These keys appear in a pop-up menu when the root menu Options key is pressed. The pop-up menu appears only when an actual file has been selected (i.e. it does not appear if a directory (folder) or volume is selected.) Cut and paste functions are available only to users with the relevant access permissions ([section 4.4](#)).

Cut	Removes a file from the list, ready for 'pasting' to another destination.
Copy	Copies a file from the list, ready for 'pasting' to another destination.
Delete	Removes a file from the memory.
New	Allows a new directory (folder) to be created
Paste	Places a 'cut' or 'copy' file into the new destination.
Refresh	Refreshes the display.

A key's legend is hidden (displayed in white) if at any time its function is not applicable.

5.2 THE HIDE KEY

The Hide key at the top right corner of the display screen is used to hide (show) Type, Date and Bytes information, allowing the full file name text string to appear.

5 FILE (Cont.)

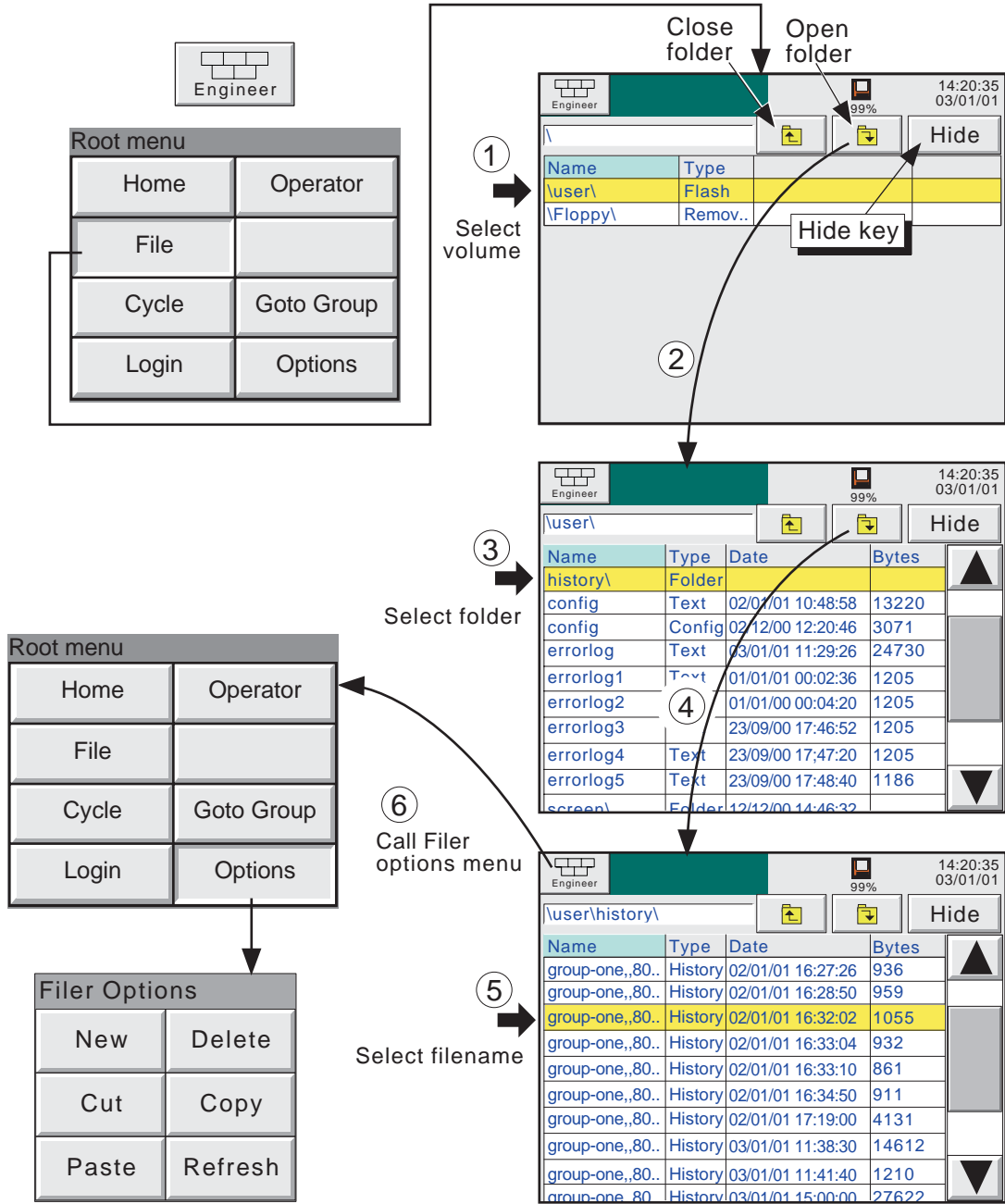

Figure 5 File system overview

5.3 FILE STRUCTURE

5.3.1 Software versions prior to 3.1

The file structure on the floppy disk or pc card, is as depicted below in figure 5.3.1. The History folder contains one folder for each group fitted. Each Group folder contains all the history files for that group. Figure 5.3.1 illustrates this for a 2-group unit.

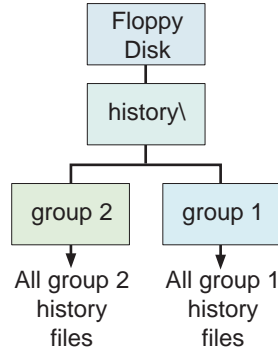

Figure 5.3.1 File structure for software versions prior to 3.1

5.3.2 Software versions 3.1 onwards

The file structure for versions 3.1 onwards is similar except in that an extra level of subdirectories has been added within the group folders. Each subdirectory contains a maximum of 32 files, there being sufficient subdirectories created, to contain all the group's history files. This is illustrated in figure 5.3.2 below.

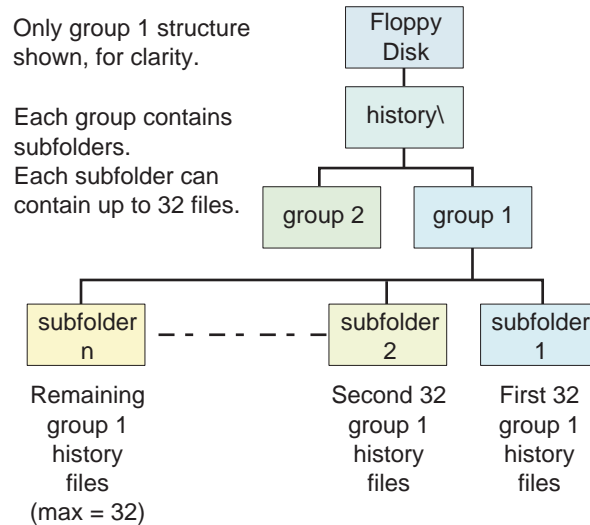

Figure 5.3.2 File structure for software versions 3.1 onwards

The subfolder names are the numerical part of the first history file that they contain. For example if the first file name is Furnace1 Temp~80155F2601000120.uhh, then the subdirectory name will be 80155F2601000120. If there are more than 32 files, the next subdirectory name is 80155F2601000140* (assuming the file names are contiguous).

* 20 in hex = 32 in decimal

This page is deliberately left blank

ANNEX A: SPECIFICATION

INSTALLATION CATEGORY AND POLLUTION DEGREE

This product has been designed to conform to BS EN61010 installation category II and pollution degree 2. These are defined as follows:

Installation category II

The rated impulse voltage for equipment on nominal 230V ac mains is 2500V.

Pollution degree 2

Normally, only non-conductive pollution occurs. Occasionally, however, a temporary conductivity caused by condensation shall be expected.

TECHNICAL SPECIFICATION (Recorder)**Inputs/Outputs**

3- or 6-channel universal input (as specified at time of order)
 1 Change-over relay output board (option)
 Transmitter power supply (non-isolated) (option)
 3.5 inch floppy disk

Other options

Software: CSV archive file format
 E-mail (If Ethernet / relay option fitted)
 File transfer protocol (FTP) (If Ethernet / relay option fitted)
 Log Scales
 Maths calculations
 Remote viewer (If Ethernet / relay option fitted) ('Lite' and 'Full' versions of Remote Viewer available)
 Security Manager
 Totalisers/Counters/Timers
 Two groups

Hardware: Transmitter power supply (non-isolated)
 Low supply-voltage option

Environmental Performance

Temperature limits	Operation:	5 to 40°C
	Storage:	-20 to + 50°C
Humidity limits	Operation:	20% to 80% RH (non - condensing)
	Storage:	20% to 80% RH (non - condensing)
Altitude (maximum)		<2000 metres
Protection	Standard bezel/display:	IP54 (when panel mounted)
	Standard sleeve:	IP20
Shock		BS EN61010
Vibration (10 Hz to 150Hz)		2g peak

Physical

Panel mounting	DIN43700
Bezel size	144mm x 144mm
Panel cutout	138mm x 138mm (-0.0 + 1.0) mm
Depth behind bezel	248 mm (213mm without terminal cover)
Weight	3 kg. max.
Mounting angle	±15 ° from vertical

Electromagnetic compatibility (EMC)

Emissions and immunity	BS EN61326
------------------------	------------

Electrical safety

BS EN61010. [Installation category II, Pollution degree 2](#)

Power requirements

Line voltage	Standard:	85 to 265V; 47 to 63 Hz or 110 to 370Vdc.
	Low voltage option:	20 to 42V RMS; 45 to 400 Hz, or 20 to 54V dc.
Power (max.)		60 VA (Inrush current 36A)
Fuse type	Recorder:	None
Interrupt protection	Standard:	200msec. at 240V ac, with full load.
	Low voltage option:	20msec. at 20V dc or RMS, with full load.

Back-up battery

Type	Poly-carbonmonofluoride/lithium (BR2330). Part Number PA261095
Support time	A fully-charged, new battery supports the Real-Time Clock for a minimum of 1 year with the recorder unpowered
Replacement period	3-years
Stored data	Time; date; values for totalisers, counters and timers; batch data; values for those maths functions with history, such as Fvalue, Rolling average, Stopwatch etc.

TECHNICAL SPECIFICATION (RECORDER) (Cont.)

Operator interface

Colour STN LCD with cold cathode backlighting, fitted with resistive, analogue touch panel.

Screen specification 1/4 VGA Resolution = 320 x 240 pixels

Update/archive rates

Input/relay output sample rate: 8 Hz.

Display update: 1 Hz,

Archive sample value: Latest value at archive time

Trended/displayed value: Latest value at display update time.

Transmitter power supply (non-isolated)

Output voltage 24 Volts \pm 10%.

Maximum current Continuous: 120 mA (total for all outputs).

Peak: 240 mA (total for all outputs).

Isolation (dc to 65Hz; BS EN61010) Installation category II; Pollution degree 2

Non isolated. 0 V returns are connected to chassis ground.

TECHNICAL SPECIFICATION (Universal inputs)

General*

Termination	Inputs:	22 - way Edge connector/terminal block
Max. number of inputs		six
Input ranges		-38 mV to +38mV; -150 mV to +150mV; -1 Volt to +1Volt; -10 Volts to + 10Volts
Input types		Dc volts, dc millivolts, dc milliamps, (with external shunt), thermocouple, 2/3 wire resistance temperature detector (RTD), Ohms, Contact closure (not channel 1) (Minimum contact closure = 60msec.)
Input type mix		Freely configurable
Sample rate		See 'Update information' above
Noise rejection (48 to 62Hz)	Common mode:	>140dB (Channel to channel and channel to ground)
	Series mode:	>60dB
Maximum common mode voltage		250Volts continuous
Maximum series mode voltage		45mV at lowest range; 12Volts peak at highest range
Isolation (dc to 65Hz; BS EN61010)		Installation category II: Pollution degree 2 300V RMS or dc channel to channel (double insulation), channel to common electronics (double insulation) and channel to ground (basic insulation)
Dielectric strength Channel to ground:		1350Vac for 1 minute.
	Channel to channel:	2300Vac for 1 minute
Insulation resistance		>10MΩ at 500V dc
Input impedance 10V range:		68.8kΩ
	Other ranges:	>10MΩ
Overvoltage protection		50V peak (150V with attenuator)
Open circuit detection		± 57nA max
	Recognition time:	500mSec
	Minimum break resistance:	10MΩ

DC input ranges

Shunt	Externally mounted resistor modules
Additional error due to shunt	0.1% of input
Performance	See table

Low Range	High Range	Resolution	Maximum error (Instrument at 20 deg C)	Worst case temperature performance
-38 mV	38 mV	1.4 μV	0.085% input + 0.051% range	80ppm of input per deg C
-150 mV	150 mV	5.5 μV	0.084% input + 0.038% range	80ppm of input per deg C
-1 V	1 V	37 μV	0.084% input + 0.029% range	80ppm of input per deg C
-10 V	10 V	370 μV	0.275% input + 0.030% range	272ppm of input per deg C

TECHNICAL SPECIFICATION (Universal inputs) (Cont.)

Resistance inputs

Temperature scale ITS90
 Types, ranges and accuracies See tables (values exclude influence of lead resistance)
 Influence of lead resistance Error: Negligible
 Mismatch: 1Ω/Ω

Low Range	High Range	Resolution	Maximum error (Instrument at 20°C)	Worst case temperature performance
0Ω	150Ω	5mΩ	0.045% input + 0.110% range	35ppm of input per deg C
0Ω	600Ω	22mΩ	0.045% input + 0.065% range	35ppm of input per deg C
0Ω	6kΩ	148mΩ	0.049% input + 0.035% range	35ppm of input per deg C

RTD type	Overall range (°C)	Standard	Max. linearisation error
Cu10	-20 to + 400	General Electric Co.	0.02°C
Cu53	-70 to + 200	RC21-4-1966	< 0.01°C
JPT100	-220 to + 630	JIS C1604:1989	0.01°C
Ni100	-60 to + 250	DIN43760:1987	0.01°C
Ni120	-50 to + 170	DIN43760:1987	0.01°C
Pt100	-200 to + 850	IEC751	0.01°C
Pt100A	-200 to + 600	Eurotherm Recorders SA	0.09°C
Pt1000	-200 to + 850	IEC751	0.01°C

Thermocouple data

Temperature scale ITS90
 Bias current 0.05nA
 Cold junction types Off, internal, external, remote.
 Remote CJ source: Any input or maths channel
 Internal CJ error 1°C max with instrument at 25°C
 Internal CJ rejection ratio 50:1 minimum
 Upscale/downscale drive Types: 'High', 'low' or 'none' selectable for each thermocouple channel.
 Additional error: Typically 0.01°C - depends on wiring. (Detect current = 57nA.)
 Types, ranges and accuracies See table

T/C type	Overall range (°C)	Standard	Max. linearisation error
B	0 to + 1820	IEC584.1	0 to 400°C = 1.7°C 400 to 1820°C = 0.03°C
C	0 to + 2300	Hoskins	0.12°C
D	0 to + 2495	Hoskins	0.08°C
E	-270 to + 1000	IEC584.1	0.03°C
G2	0 to + 2315	Hoskins	0.07°C
J	-210 to + 1200	IEC584.1	0.02°C
K	-270 to + 1372	IEC584.1	0.04°C
L	-200 to + 900	DIN43710:1985 (To IPTS68)	0.02°C
N	-270 to + 1300	IEC584.1	0.04°C
R	-50 to + 1768	IEC584.1	0.04°C
S	-50 to + 1768	IEC584.1	0.04°C
T	-270 to + 400	IEC584.1	0.02°C
U	-200 to + 600	DIN43710:1985	0.08°C
NiMo/NiCo	-50 to + 1410	ASTM E1751-95	0.06°C
Platinel	0 to + 1370	Engelhard	0.02°C
Ni/NiMo	0 to + 1406	Ipsen	0.14°C
Pt20%Rh/Pt40%Rh	0 to + 1888	ASTM E1751-95	0.07°C

TECHNICAL SPECIFICATION (Ethernet/Relay output board option)

Network Communications

Type	IEEE802.3 10BaseT
Cable	Type: CAT5
	Maximum length: 100 metres
	Termination: RJ45 telephone connector
Transport protocol	TCP I/P, FTP

Relay

GENERAL

Number of relays per board	One
Maximum number of relay boards	One
Type	Single pole changeover (form C)
Termination	Three-way connector
Estimated mechanical life of relay	30,000,000 operations
Update rate	See ' Update/archive rates ' in 'Universal inputs specification' above

AC load ratings

Derating

The figures given below are for resistive loads. For reactive or inductive loads, de-rate in accordance with graph 1, in which

- F1 = Actually measured results on representative samples
- F2 = Typical values (according to experience)
- Contact life = Resistive contact life x reduction factor.

Maximum switching power	500VA
Maximum contact voltage	250V providing this does not cause the maximum switching power to be exceeded
Maximum contact current	2 Amps providing this does not cause the maximum switching power to be exceeded

DC load ratings

Maximum switching power	See graph 2 for operating volt/Amp envelope
Maximum contact voltage/current	See graph 2 for examples.

Safety isolation

Isolation (dc to 65 Hz; BS EN61010)	Installation category II ; Pollution degree 2
Relay to relay:	300V RMS or dc (double insulation)
Relay to ground:	300V RMS or dc (basic insulation)

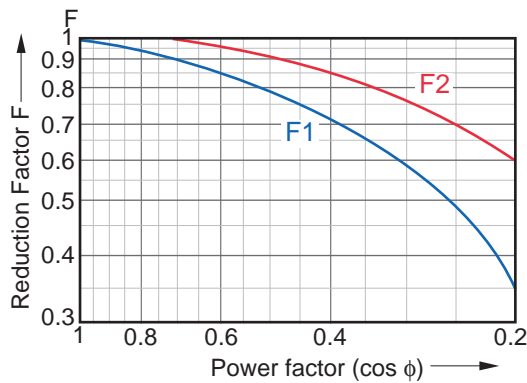

Graph 1 Derating curves for ac loads

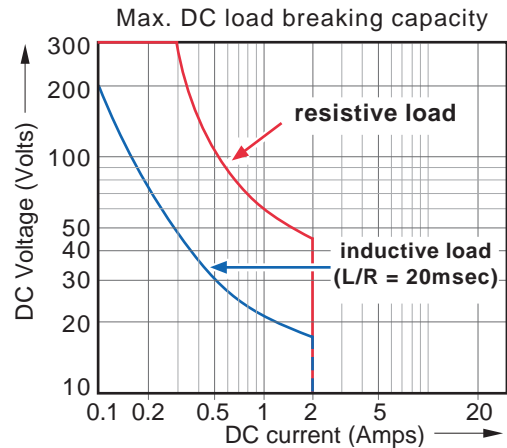

Graph 2 DC load switching curves

ANNEX B: REFERENCE

B1 DIAGNOSTICS DISPLAY

At power-up, continuously hold a finger in contact with the screen until (after approximately 30 seconds) the diagnostic display appears as shown in figure B1. If no further action takes place within approximately five minutes, the display times-out to the calibration display described in [section B2](#), below.

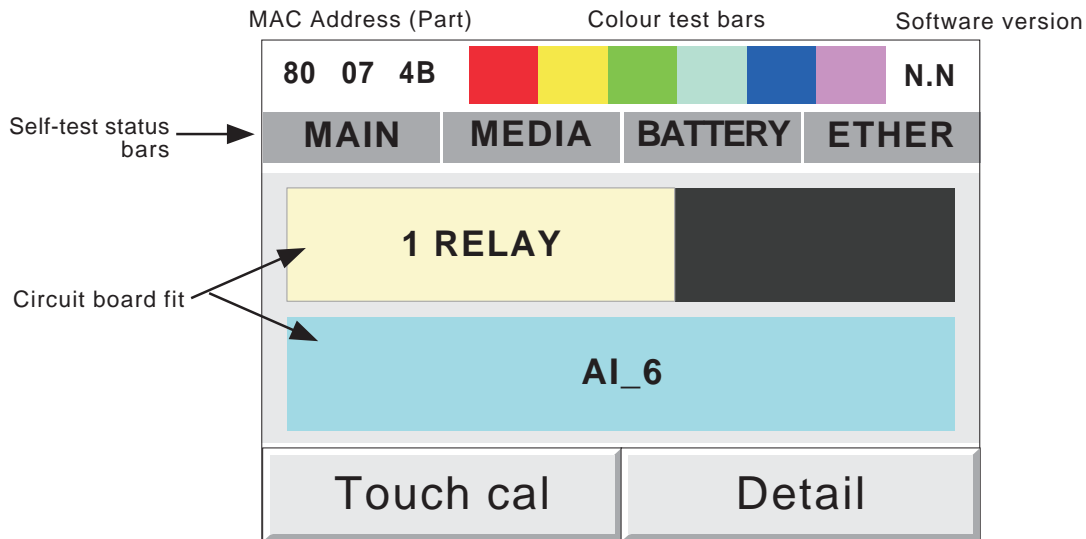

Figure B1 Top-level diagnostic display

B1.1 DISPLAY DETAILS

Note: The diagnostic display does not include details of either of the Transmitter Power Supply options (if fitted).

MAC ETHERNET ADDRESS

This unique hex address is for factory use only. See [section 4.5.1](#) for the instrument's full MAC address.

COLOUR TEST BARS

This colour 'swatch' allows a judgement to be made as to the correctness of the display colour rendering.

SOFTWARE VERSION NUMBER

This shows the version number of the software fitted to the recorder.

SELF-TEST STATUS BARS

These four areas show the status of the main circuit board (MAIN), the disk fitted (MEDIA), the battery and the Ethernet/relay option board (not yet implemented). In each case, if the bars are grey, then no faults have been detected; if any one or more of them is flashing red/white, then a fault has been found.

MAIN

This tests the Dynamic RAM (DRAM), the Static RAM (SRAM) and the flash memory. The results can be displayed by operating the 'Detail' key. See figure B1.1.

(Continued)

SELF-TEST STATUS BARS (Cont.)**MEDIA**

This sends a message to the disk, and then tries to read it back. Failure to succeed might be any one or more of the following:

1. No disk was fitted when the test was initiated.
2. The disk is unformatted or incorrectly formatted.
3. The disk is too full (less than 1kB remaining) for the message to be written to it.

BATTERY

This area flashes when the battery needs to be replaced (section B3). The test is performed once every 15 minutes.

ETHER

Not applicable to this release.

CIRCUIT BOARDS FITTED

The major part of the display screen is taken up with a representation of the rear of the recorder, showing what input and output cards are fitted in each circuit board slot. 1_Relay represents the Ethernet/Relay output board; AI_6 represents the six analogue inputs on the main board.

TOUCH CAL

This key initiates the display calibration (offset correction) procedure, described in section B2 below.

DETAIL

Touching this key causes the main board test results to be displayed, as shown in figure B1.1 below.

To quit diagnostics, switch the recorder off, then, after a few seconds, switch it back on again

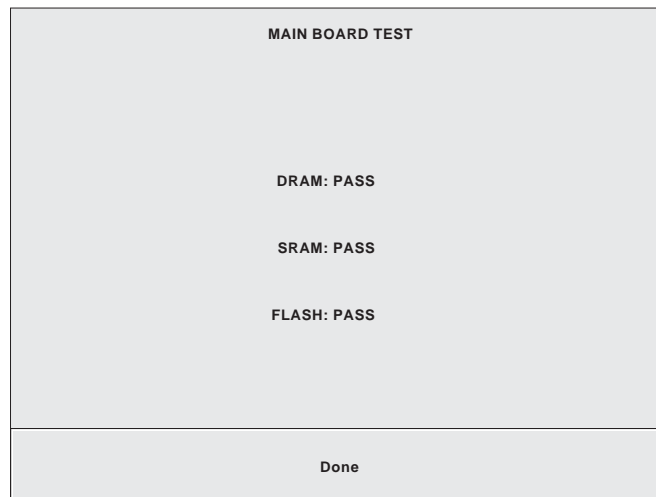

Figure B1.1 Main board self-test results display

B2 SCREEN CALIBRATION (OFFSET CORRECTION)

This procedure ensures that the display screen image is positioned correctly, compared with the touch screen (so that 'what you touch is what you get'). The procedure, is necessary only rarely, if at all, and is included here only for the sake of completeness.

1. At power-up, continuously hold a finger in contact with the screen until (after approximately 30 seconds) the diagnostic display appears as shown in figure B1. Operate the Touch cal key to call the first calibration screen, as depicted in figure B2*
2. Using a soft point (> 1mm radius) of a material which will not damage the touch screen, touch the intersection of the upper set of crosshairs, as requested by the display and keep touching it until the next target appears..
3. Continue the process, according to the directions appearing on the screen. Once all the 'targets' have been accepted, the recorder returns to the diagnostic display.

* Note: The diagnostic display times-out (to the screen calibration page) after about 5 minutes. The screen calibration pages time-out to the diagnostic page after a time which depends on how much of the calibration procedure has been completed

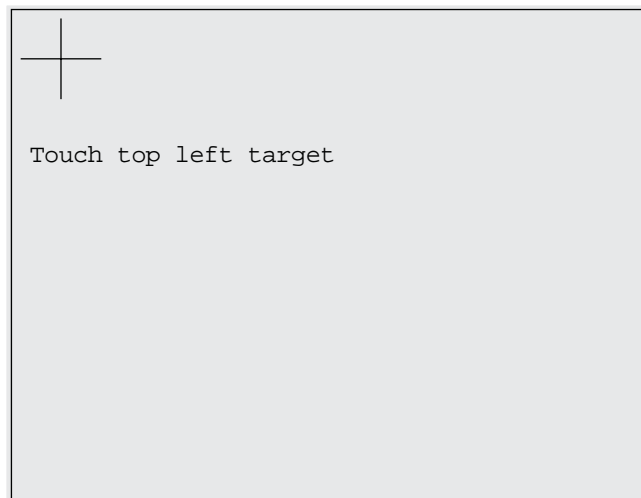

Figure B2 Initial calibration display

B3 PREVENTIVE MAINTENANCE

B3.1 Touch Screen Cleaning

CAUTION

The touch-sensitive screen used in this product is designed for use by hand only. The use of sharp or pointed implements such as pens, keys and fingernails to operate the instrument must be avoided, or irreparable damage will be done to the surface material. When cleaning the touch-screen, a moist cloth should be used, if necessary with a minimal amount of mild soap solution.

ALCOHOLS SUCH AS ISOPROPYL ALCOHOL MUST NEVER BE USED ON THE SCREEN.

B3.2 Maintenance schedule

Battery replacement - Every three years

B3.3 Battery replacement procedure

Notes:

1. The battery is of poly-carbonmonofluoride/lithium construction and should be disposed of according to local regulations covering this type of battery.
2. It is recommended that the recorder be isolated from mains (line) power before the battery is replaced. All battery backed RAM data is lost during battery change.

1. Remove the mains connector. For convenience, disconnect the relay and Ethernet connectors (if fitted).
2. Remove the rear terminal cover (A) by pressing down on the catch and lifting off. Remove the input connector (B), by pressing-in on the end clips and pulling on the connector (figure B3.2a).
3. Remove the three screws 'C' in figure B3.2b.
4. Carefully lift the front of the recorder case cover, and disconnect the two looms connecting it to the internal circuit board (figure B3.2c)
5. Push the battery out of its holder as shown in figure B3.2d.
6. Instal the new battery by pushing it into position (+ uppermost).
7. Re-connect the two looms previously disconnected, then re-assemble the recorder.

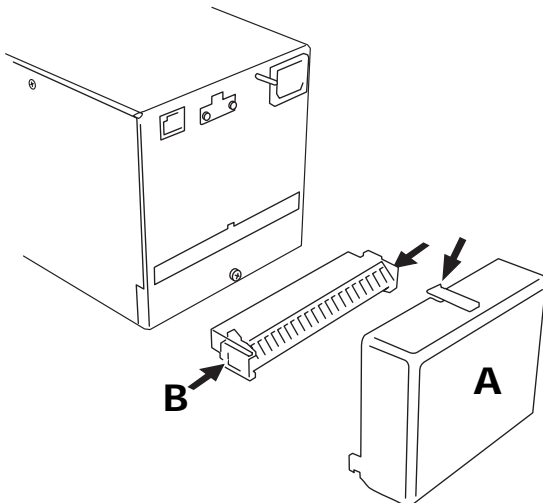

Figure B3.2a Remove terminal cover and connector

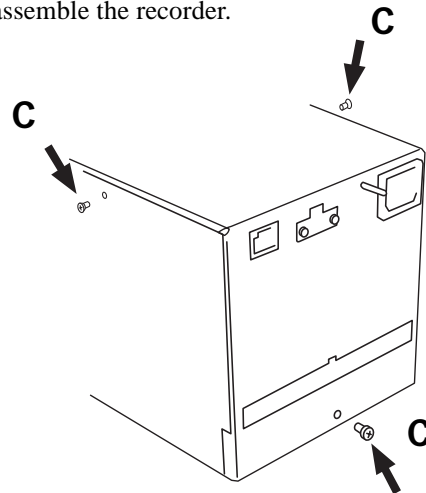

Figure B3.2b Release cover plate

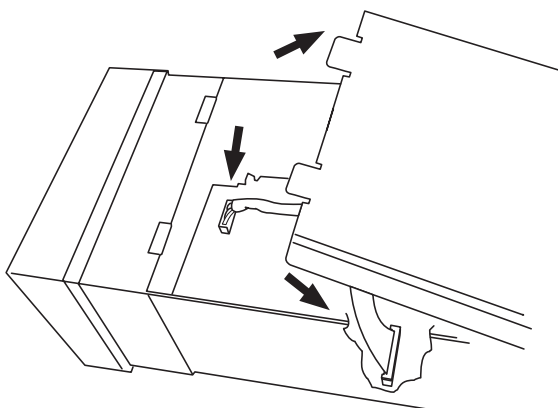

Figure B3.2c Disconnect looms; Remove cover plate

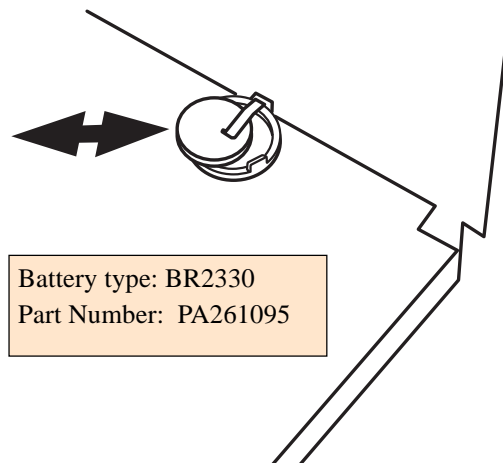

Figure B3.2d Replace battery

B4 OPTION ENABLING

In order to enable software functions, a key code or file name, obtained from the manufacturer, must be entered in the System/Key code page (Figure B4).

Note: The key code is related to the instrument number, as displayed on the key code page. Please ensure that this instrument number has been noted before applying for a code or file name.

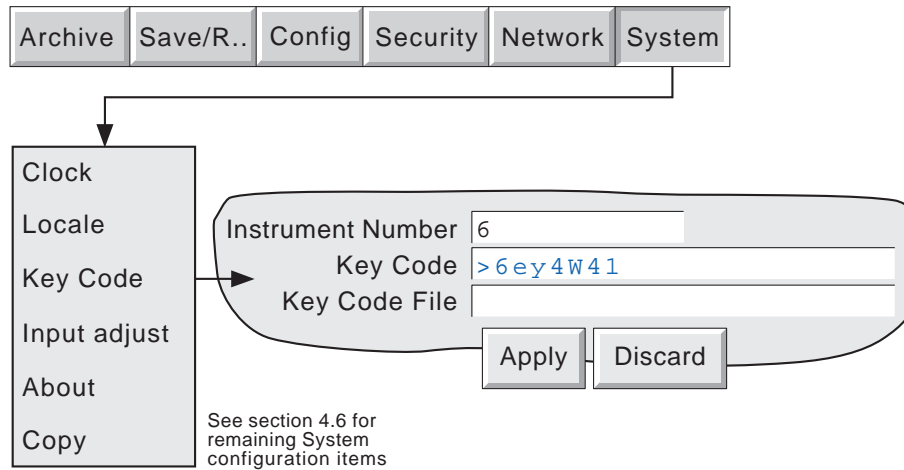

Figure B4 Option enable (key code) page

B4.1 Instrument Number

This number, unique to each recorder, is used to identify the unit should any need arise for the user to contact the manufacturer or distributor of the instrument (if, for example, the user needs to enable one or more software options.)

B4.2 Key Code

Touching this field causes a qwerty style keyboard to appear, allowing the user to enter the key code received from the manufacturer or distributor. This is an alternative to loading the Key Code File described below.

B4.3 KeyCode File

The key code may be sent to the user by, for example, e-mail. By saving the code to a floppy disk, the key code can be transferred to the recorder, and the file read from the floppy disk. Alternatively, the code can be entered manually as described above.

B5 COLOUR SELECTION

The following table, gives RGB values and decimal and hex numbers for the available channel colours. Normally, this table is necessary only when communicating over the MOBUS link.

Note: Colour representation varies from screen to screen. For this reason, it is unlikely that the colour on a PC will match those on these pages or those on the recorder display.

























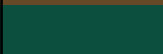

Colour	Red	Green	Blue	Decimal	Hex
	255	0	0	0	00
	0	0	255	1	01
	0	255	0	2	02
	255	191	0	3	03
	170	321	153	4	04
	170	95	0	5	05
	0	0	102	6	06
	0	95	0	7	07
	255	0	102	8	08
	255	95	51	9	09
	255	255	255	10	0A
	85	63	255	11	0B
	170	0	0	12	0C
	0	233	102	13	0D
	85	0	102	14	0E
	85	63	0	15	0F
	0	63	51	16	10
	0	255	255	17	11
	85	0	51	18	12
	255	63	0	19	13
	255	255	51	20	14
	170	0	51	21	15
	0	63	0	22	16
	255	31	204	23	17
	85	31	255	24	18
	255	95	0	25	19
	255	159	255	26	1A
	255	255	102	27	1B

Table B1, sheet 1: Colour definitions 0 to 27

B5 COLOUR SELECTION (Cont.)













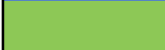

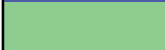









	Colour	Red	Green	Blue	Decimal	Hex
	Terracotta	170	63	0	28	1C
	Blue Babe	85	95	255	29	1D
	Lime	0	223	0	30	1E
	Blue Jive	85	31	204	31	1F
	Cucumber	0	255	153	32	20
	EuroGreen	67	107	103	33	21
	Wheatgerm	255	223	51	34	22
	Sea Blue	85	159	255	35	23
	Ginger	255	159	0	36	24
	Aqua Pool	0	63	255	37	25
	Pale Red	255	63	51	38	26
	Pale Blue	85	127	255	39	27
	Lilac	170	0	255	40	28
	Sky Blue	85	191	255	41	29
	Wild Moss	0	127	0	42	2A
	Turquoise	0	127	153	43	2B
	Pale Green	85	255	153	44	2C
	Coffee	170	127	0	45	2D
	Wicker	255	255	191	46	2E
	Black	0	0	0	47	2F
	Dark Dark Grey	48	48	48	48	30
	Dark Grey	64	64	64	49	31
	Grey	128	128	128	50	32
	Light Light Dark Grey	154	154	154	51	33
	Light Dark Grey	172	172	172	52	34
	Light Grey	192	192	192	53	35
	Light Light Grey	212	212	212	54	36
	White	255	255	255	55	37

Table B1, sheet 2: Colour definitions 28 to 55

B6 TCP PORT NUMBERS

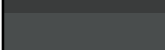
The following TCP ports are made use of by the recorder. (This information would be needed by anyone involved in setting up 'firewalls', which may be used selectively to block incoming or outgoing access to specific ports.)

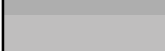
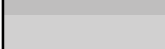
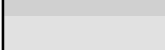
PORT	Usage
20	File Transfer Protocol - data
21	File Transfer Protocol - control
25	E-mail
123	SNTP server
502	Modbus/TCPIP communications
1264	Remote Viewer communications - general
50010	Remote Viewer communications - trend review

B7 TIME ZONES

This section gives an explanation of the time zone abbreviations listed in the System/Locale/Time Zone pick list. The list starts at GMT, travelling Eastwards round the world.

Abbreviation	Full title	Time at noon GMT	Hours of difference
GMT	Greenwich mean time	12:00	0
UTC	Co-ordinated Universal time	12:00	0
ECT	Central European time	13:00	+1
EET	Eastern European time	13:00	+1
ART	Arabic standard time	14:00	+2
EAT	Eastern African time	15:00	+3
MET	Middle East time	15:30	+3.5
NET	Near East time	16:00	+4
PLT	Pakistan Lahore time	17:00	+5
IST	India standard time	17:30	+5.5
BST	Bangladesh standard time	18:00	+6
VST	Vietnam standard time	19:00	+7
CTT	China Taiwan time	20:00	+8
JST	Japan standard time	21:00	+9
ACT	Australia Central time	21:30	+9.5
AET	Australia Eastern time	22:00	+10
SST	Solomon standard time	23:00	+11
NST	New Zealand standard time	24:00	+12
MIT	Midway Islands time	01:00	-11
HST	Hawaii standard time	02:00	-10
AST	Alaska standard time	03:00	-9
PST	Pacific standard time	04:00	-8
PNT	Phoenix standard time	05:00	-7
MST	Mountain standard time	05:00	-7
CST	Central standard time	06:00	-6
EST	Eastern standard time	07:00	-5
IET	Indiana Eastern standard time	07:00	-5
PRT	Puerto Rico and US Virgin Islands time	08:00	-4
CNT	Canada Newfoundland time	08:30	-3.5
AGT	Argentina standard time	09:00	-3
BET	Brazil Eastern time	09:00	-3
CAT	Central African time	11:00	-1

This page is deliberately left blank

B8 MENU STRUCTURE

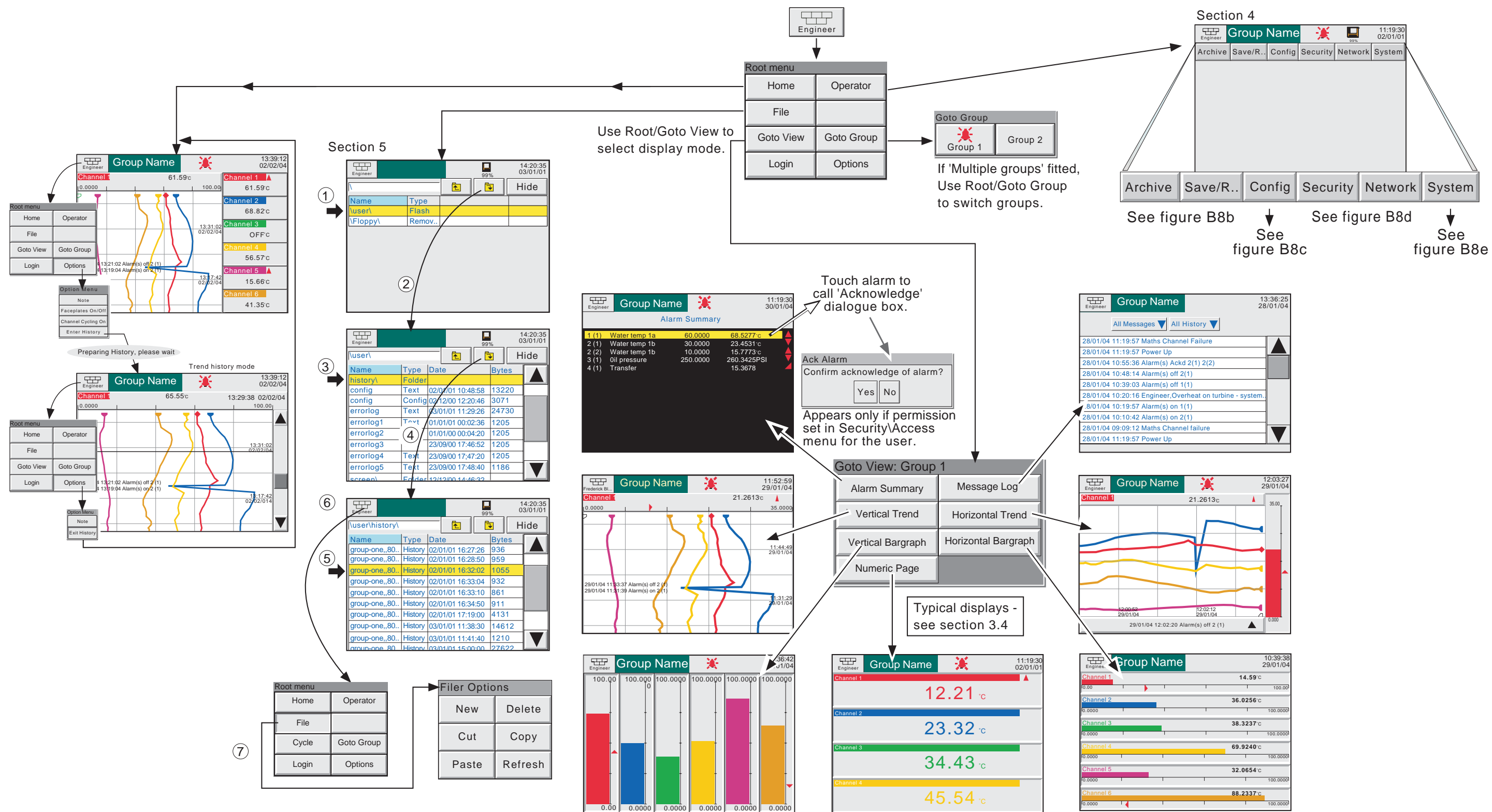

Figure B8a Menu structure sheet 1 (Root Menu)

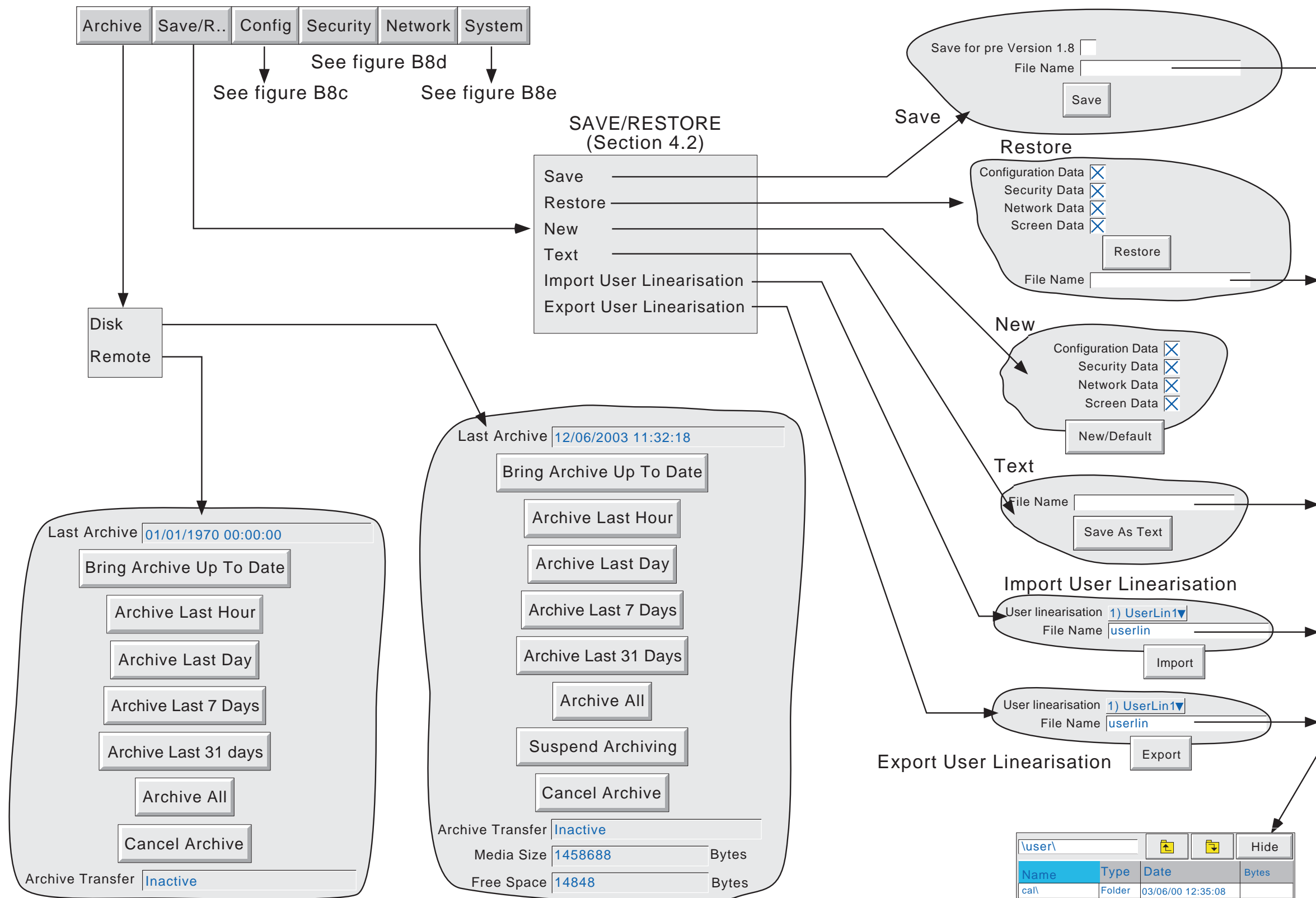

Figure B8b Menu structure sheet 2 (Archive and Save/Restore keys)

B8 MENU STRUCTURE (Cont.)

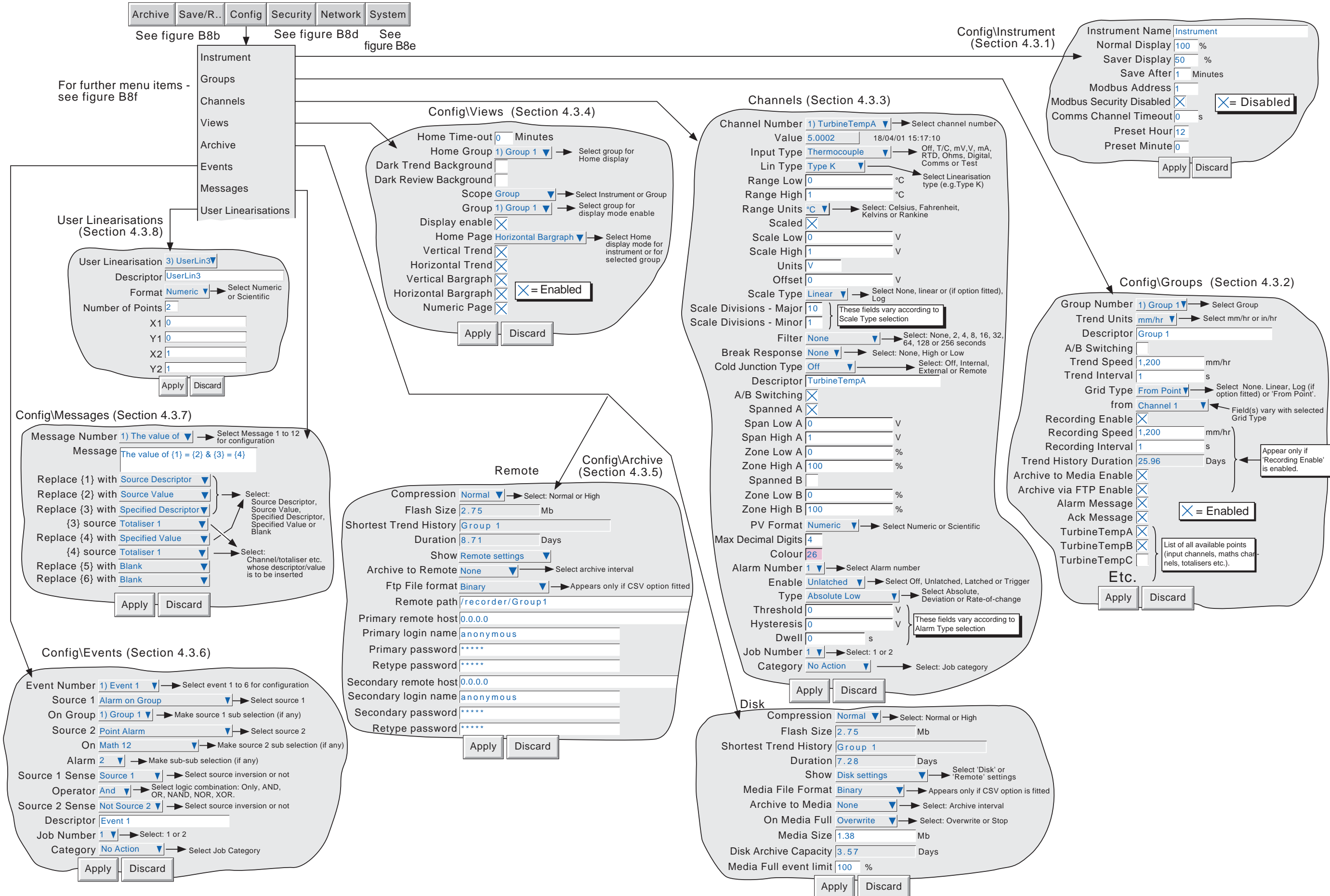

Figure B8c Menu structure sheet 3 (Config key)

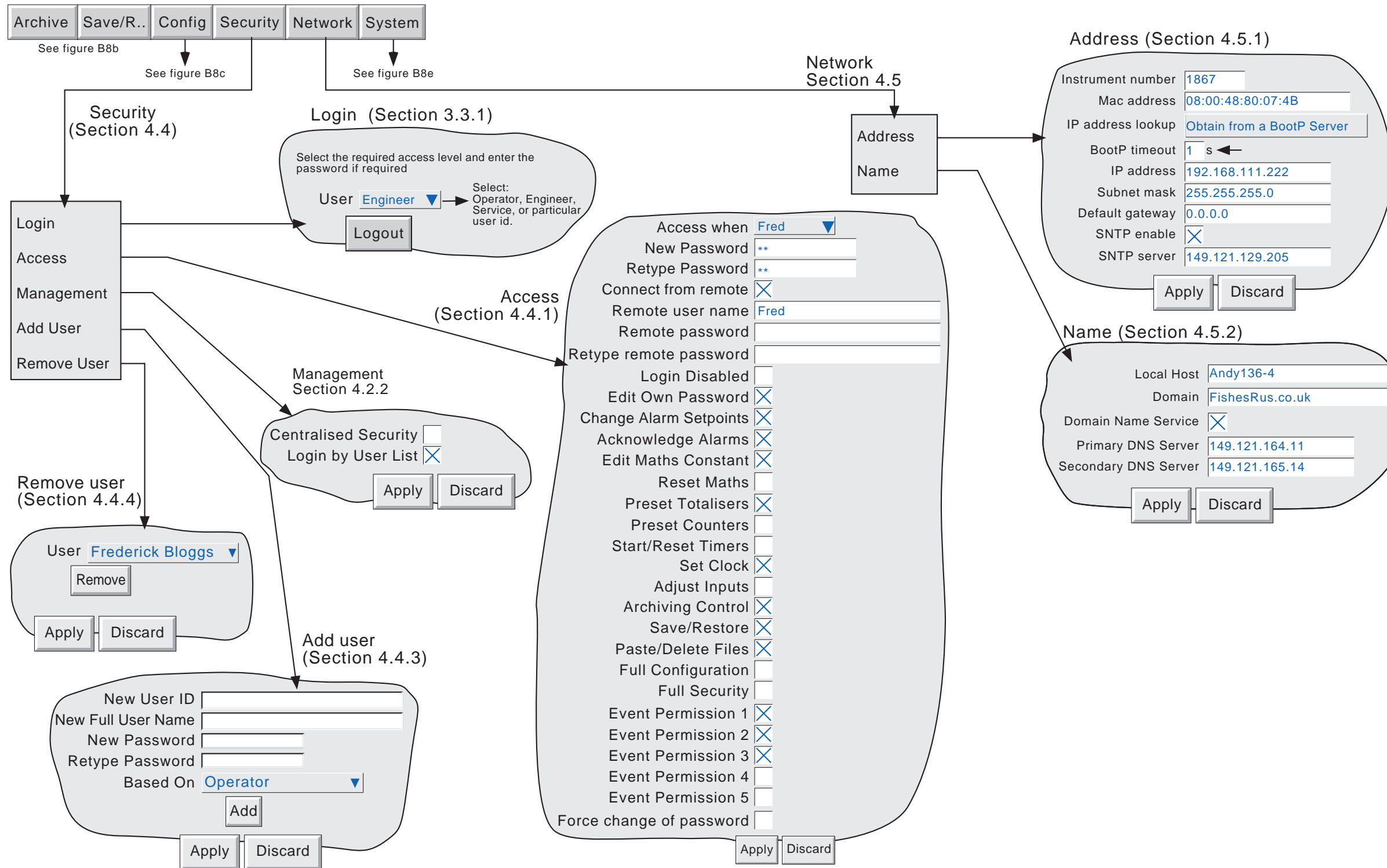

Figure B8d Menu structure sheet 4 (Security and Network Keys)

B8 MENU STRUCTURE (Cont.)

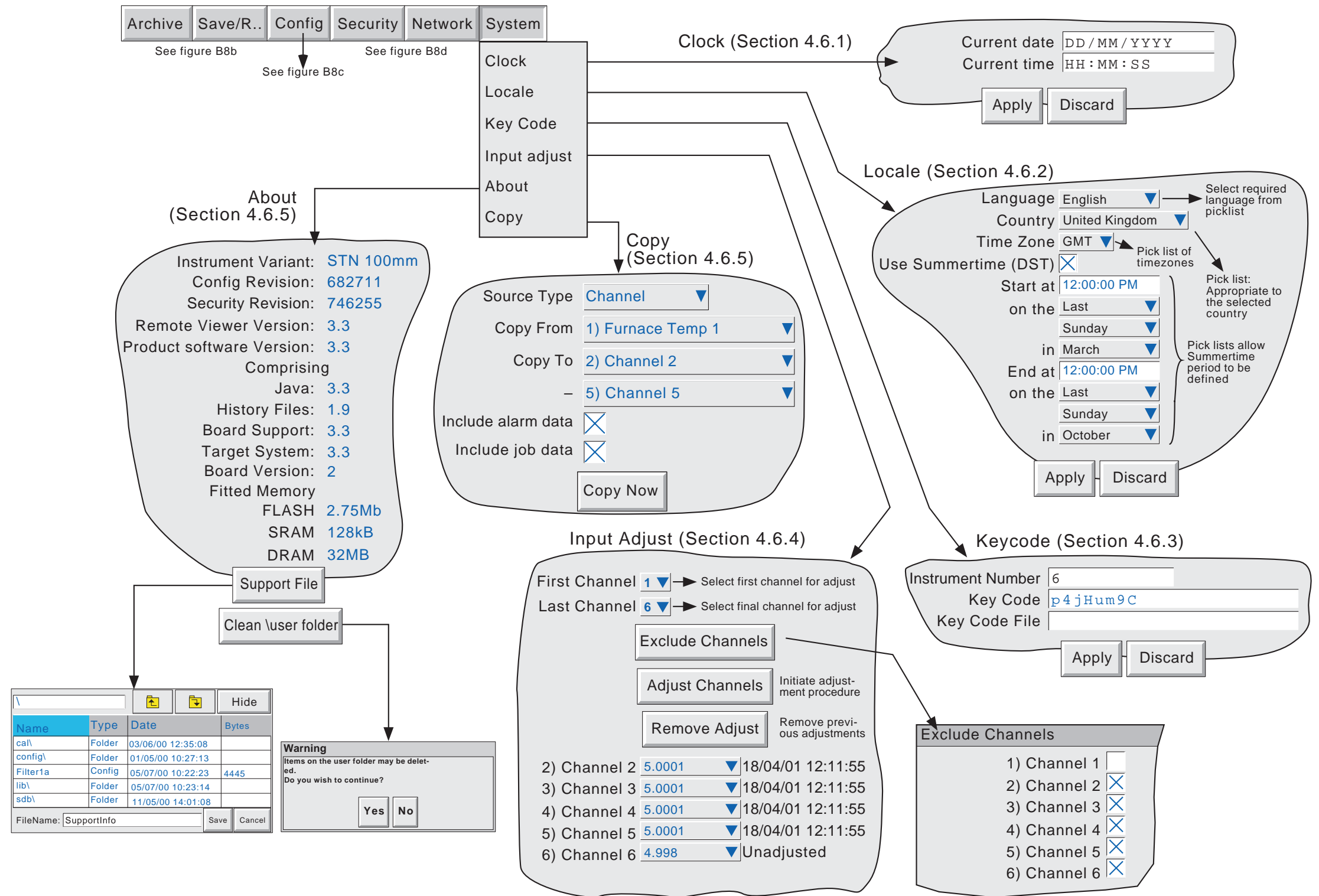

Figure B8e Menu structure sheet 5 (System key)

B8 MENU STRUCTURE (Cont.)

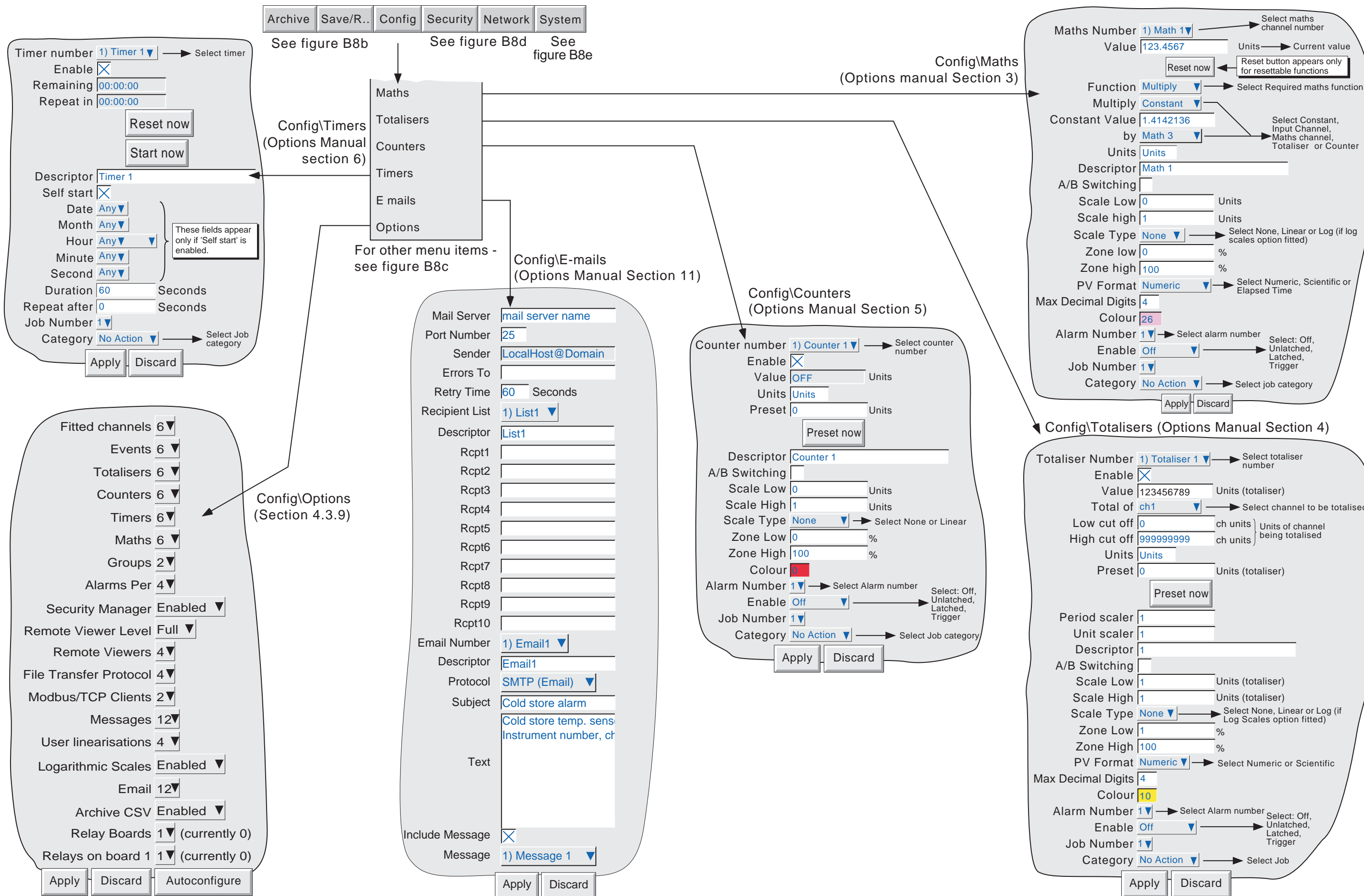

Figure B8f Menu structure sheet 4 (Config key - Options)

INDEX

Symbols

.uhq file 88
 {n} source 68

A

A/B Switching 44, 52
 About 87
 Absolute high/low 54
 AC supply voltage range 11
 Access
 Access when: 75
 Levels 74
 To configuration 22
 ACK Message 47
 Acknowledge alarms
 Permission 76
 Acknowledging alarms 15, 17, 47, 57
 Add user 79
 Address
 IP 80
 MAC 80, 107
 Adjust inputs 84
 Permission to 77
 Alarm
 Acknowledge 14, 15, 17, 47, 57
 Job 95
 Message enable/disable 47
 Permission 76
 Configuration 54
 Disable Job 95
 Icons (Channel) 13
 Message enable/disable 46
 Messages 57
 Summary page 14
 Type 54
 Illustrations 56, 57
 Alarm on Group Event Source 65
 Amount (R of C alarms) 55
 AND 66
 Archive
 Archive media % full 66
 Configuration 60
 Control permission 77
 Failed (instrument alarm) 16
 File formats 63
 Key 35
 Manual initiation to disk 35
 Manual initiation to host 36
 Period selection (disk) 61
 Suspend 35
 To Media 46
 To Remote 62
 via FTP 46
 Average time 55

B

Bargraph displays 30
 Battery
 Diagnostics 108
 Icon 17
 Low (Event Source) 66
 Replacement 110
 Battery back RAM cleared 16
 Blue line across the chart 26
 BootP timeout 80
 Break response 52
 Brightness control 43
 BSpC 23

C

Cable
 Signal, Max/min sizes 10
 Supply voltage (min. size) 11
 Caps 23
 Change
 Alarm setpoint permission 76
 Battery
 Indicator 17
 Procedure 110
 Constant value 76
 Change time (R of C alarms) 55
 Channel
 Colour 53
 Configuration 48 to 73
 Copy 89
 Damping 51
 Descriptor 52
 Channel error (instrument alarm) 16
 Channel failure (instrument alarm) 16
 Character set 23
 Chart grid type/divisions 45
 CJC 52
 Clean \user folder 88
 Cleaning 109
 Clock
 Preset 43
 Job 93
 Setting 84
 Clock failure (instrument alarm) 16
 Cold junction compensation 52
 Colour B select job 95
 Comms channel timeout 43, 65
 Config revision 87
 Configuration
 A/B Switching 44, 52

Configuration (Cont.)

Access	22
Alarm	54
Amount	55
Average time	55
Change time	55
Deviation value	55
Dwell period	55
Hysteresis	55
Reference value	55
Threshold	55
Type	54
Archive	60
Break response	52
Channel	48 to 73
Cold junction compensation	52
Country	84
Date format	84
Decimal point	53
Display brightness settings	43
Event	65
Filter	51
Group	44
Input low/high	49
Instrument	43
Language	84
Linearisation range	50
Linearisation type	49
Lock indication	17
Network	80
Offset	50
Options	73
Recorder	40 to 73
Scale	50
Security	74
Shunt value	49
Span	52
Summertime	84
Time and date	84
Time zone	84
Trace Colour	53
User Lin. tables	71
Views	58
Zone	53
Configuration lock indicator	17
Connect from Remote	75
Connector locations	10
Contents of group	47
Contrast control	14
Copy	
Facility	89
Copy key	97
Counter	
Copy	89
Jobs	93
Country, Selection of	84
CSV	
Date/Time format	64
Use Tab delimiter	64
Cursor keys	18
Cut key	97

D

Damping	51
Dark Background	58
Data	
Compression ratio	61
Date	
and time setting	84
Format	84
Daylight saving setup	84
DC supply voltage range	11
Decimal point position	53
Decrement counter job	93
Default Gateway	81
Delete key	97
Descriptor	
Channel	52
Event	67
Group	13, 44
Instrument	43
Detail	108
Deviation alarms	54
Diagnostics display	107
Disable	
Counter	93
Login	76
Timer	94
Totaliser job	91
Disk	
Access	11
Activity indicator	17
Free space	17
Full response	62
Icon	17
Size	62
Display	
Brightness	43
Calibration	109
Contrast	14
Modes	25 to 32
Enable/disable	58, 59
Home selection	58
Horizontal bars	31
Horizontal Trend	28
Numeric	32
Vertical bars	30
Vertical Trend	25
Update rate	103
Values (truncation of)	13
Domain Name Service (DNS)	82
Drive Relay Job	91
Dwell	55

E

E-mail	
Job	96
Earlier messages	20
Edit Password permission	76
Enabling	
Display modes	59
Options	111
Engineer, Access level	21, 74
Error indicator	14
Ethernet	
Address	107
Specification	106
Event	
Configuration	65
Copy	89
Permission	77
Source	65
Source 1 sense	66
Source sense	66
Exclamation mark symbol	16
Export user linearisation	39
External CJ	52

F

Faceplates (on/off)	30
File	97
Structure	99
File formats (archiving)	63
File transfer (FTP) facility	36
Filer Option menu	97
Filter	51
First switch-on	21
Flash size	61
Floppy disk alarms	16
Folder keys	18
Force change of password	77
FTP File format	61
FTP file format	63
FTP Icon	17
Full configuration access	77
Full security access	77
Full user name	79

G

Global Alarm Event Source	65
Global Unack'd Alarm Event Source	65
Goto	
Group	18
View	18
Green line across the chart	26
Grid type/divisions	45
Group	
Configuration	44
Copy	89
Display enable	59
Home	58
Name	13, 44

H

Hardware version	87
History	46
Amount of	26, 46
Home	
Group	58
Page (Display mode)	59
Timeout	58
Horizontal bargraph	
Display	31
Enable	59
Horizontal trend enable	59
Hysteresis	55

I

Import	
User linearisation	39
Increment counter job	93
Input	
Adjust	77, 84
Board specification	104
Configuration	49
Low/high	49
Type selection	49
Inserting and Removing Disk/PC cards	11
Installation	
Category	101
Electrical	10 to 11
Mechanical	8 to 9
Instrument	
Alarm	
Event source	65
Alarms	16
Configuration	43
Name	43
Number	80
Variant	87
Insufficient non-volatile memory	16
Internal flash (instrument alarm)	16
Invalid Password Entry	66
IP Address	80
Look-up	80
Manual entry	80

J

Jobs	57, 67, 91
Alarm Acknowledge	95
Alarm Disable	95
Clock	93
Counter	93
E-mail	96
Maths	92
Recording	94
Timer	94
Totaliser	91
Trend	95

K

Key Code (File)	111
Keycode	84

L

Labelling symbols	7
Language selection	84
Latched	54
Later messages..	20
Left cursor key	18
Line across the chart	26
Linear chart grid	45
Linear scales	50
Linearisation function	49
User entered	71
Custom units	50
Local Host	82
Log	
Chart grid	45
Scale	50
Logged out	21
Login	22
Disable	76
Key	18
Logout key	74

M

MAC Address	80, 107
MAIN (Diagnostics)	107
Maintenance	109
Manual archive	
To disk	35
To host computer	36
Maths	
Reset Job	92
Maths Channel Partial Failure	66
Maths Copy	89
Maximum number of history files	62
MEDIA (Diagnostics)	108
Media File format	61
Media full event limit	62
Media size	62
Memory size	61, 87
Menu structure	
Archive Key	118
Config Key	
Basic recorder	119
Options	122
Network Key	120
Root menu	117
Save/R(estore) Key	118
Security Key	120
System Key	121
Message	
Copy	89
Messages	68
Alarm	57
Enable/disable	46
Entry	68
Example	70
Job	92
Log	19
Operator entered	33
Modbus	
Address	43
Security disabled	43

N

NAND	66
Navigation keys	18
Network	
Configuration	80
Name	82
Specification	106
Network alarms	16
New	
Configuration	38
Key	97
Password	75
New Full User Name	79
New user ID	79
No action	91
No chart grid	45
NONE	66
NOR	66
Not recommended to archive..	46
Notes, Operator	33
Numeric	
Display	53
Enable	59

O

Offset	50
Offset correction (touch screen)	109
Ok	23
On becoming active/inactive/acknowledged	91
Open/Close folder keys	18
Operator	
Access level	21, 74
Event logic	66
Notes (Messages)	33
Option configuration	73
Options Key	18
OR	66
Ovr	23

P

Password	
Force change of	77
Passwords	74
Edit permission	76
Editing	74
Paste key	97
Paste/delete file permission	77
PC Card access	11
Point Alarm	65
Pollution degree	101
Port Usage (TCP)	114
Power-up event source	66
Preset	
Clock	43
Job	93
Counter	93
Permission	76
Hour/Minute	43
Totaliser	76
Job	91

P (Cont.)

Preventive maintenance	109
Primary	
DNS Server	82
Login Name	63
Remote Host	63
PV Format	53

R

Range low/high/units	50
Rate-of-change alarms	54
Recorder	
Configuration. <i>See Section 4.3</i>	
Dimensions	9
Electrical installation	10
Panel installation	8, 9
Serial Number	111
Specification	102
Synchronization	8, 43
Time and date setting	8
Unpacking	8
Wiring	10
Recording	
Enable	46
Enable/Disable	94
Jobs	94
Speed/interval	46
Red line across the chart	26
Reference value	55
Refresh key	97
Relay	
Rive relay job	91
Specification	106
Wiring	10
Remote	
Cold Junction Compensation	52
Path	62
User name/password	76
Remote viewer network menu	80
Removable media instrument alarms	16
Remove user	79
Replace {n} with	68
Reset	
Maths function	92
Timer	94
Permission	76
Restore	38
Right cursor key	18
Root key	18
RTD type selection	49

S

Safety notes	7
Sample rates	103
Save for Pre version 1.8	38
Save/Restore	37
Permission	77
Scale	
Divisions (Major/Minor)	50
Type	50
Scaled tick box	50
Scientific display	53
Scope (Display modes)	59
Screen	
Calibration	109
Saver	43
Secondary	
DNS Server	82
Login	63
Password	63
Remote Host	63
Security	
Configuration	74
Levels	74
Security revision	87
Service level access	21
Set clock permission	76
Setting the time and date	84
Shift	23
Shortest trend history	61
Show Disk settings	61
Shunt value entry	49
Signal Wiring	10
SNTP (instrument alarms)	16
SNTP server	8
Software version	87
Source 1 sense	66
Source 2 sense	66
Source descriptor/value	68
Source Types	65
Span B select job	95
Span Configuration	52
Specification	
Input board	104
Recorder, general	102
Relay board	106
Transmitter Power Supply	103
Specified descriptor/value	68
Speed/interval B job	95
Start timer permission	76
Status bar	13
Subnet Mask	81
Summary page (Alarm)	14
Summertime setup	84
Supply voltage	11
Support file	88
Suspend Archiving	35
Symbols used on labels	7
Synchronization of recorders	8, 43
System configuration	83

T

Tag, Channel	52
TCP port usage	114
Text	
Save and Restore	38
String entry	23
Thermocouple type selection	49
Threshold	55
Time	
Change annotation	26
Format	84
Permission to set	76
Setting	84
To fill disk/memory	62
Zone selection	84
Time synch. instrument alarm	16
Timeout	58
Comms chammel	43
Timer	
Copy	89
Jobs	94
Start/Reset Permission	76
Timer Active Event Source	65
Totaliser	
Copy	89
Jobs	91
Touch Cal	108
Touch screen	
Calibration	109
Precautions	109
Trace	
Colour	53
History, maximum	46
History display	46
Transmitter Power Supply specification	103
Trend	
History	
Duration	46
Shortest.....	61
History display	26
Interval/Speed/Units	44
Jobs	95
Speed/interval	45
Trend speed/interval B job	95
Trigger	54
Truncation of display values	13

U

Un'ackd Alarm on group	65
Unack'd point alarm	65
Unlatched	54
Unsupported File message	38
User	
Adding and removing	79
Password	79
User linearisation table	
Configuration	71
Custom units	50
Importing/Exporting	39
User logged in Event Source	66
User name (full)	79

V

Value entry	23
Version numbers	87
Vertical bargraph	
Display	30
Enable	59
Vertical trend enable	59
Views configuration	58

W

Whilst active/inactive/unacknowledged	91
Wiring	
Relay	10
Signal	10
Max/min wire sizes	10
Maximum torque	10
Supply voltage	11

X

X points	71
XOR	66

Y

Y points	71
----------------	----

Z

Zone B select job	95
Zone configuration	53

Inter-Company sales and service locations

Australia

Eurotherm Pty. Limited.
Unit 10.
40 Brookhollow Avenue,
Baulkham Hills,
NSW 2153

Telephone: 61 2 9634 8444
Fax: 61 2 9634 8555
e-mail: eurotherm@eurotherm.com.au
<http://www.eurotherm.com.au>

Austria

Eurotherm GmbH
Geiereckstraße 18/1,
A1110 Wien,

Telephone: 43 1 798 76 01
Fax: 43 1 798 76 05
e-mail: eurotherm@eurotherm.at
<http://www.eurotherm.at>

Belgium and Luxemburg

Eurotherm S.A./N.V.
Rue du Val-Notre-Dame 384,
4520 Moha (Huy)
Belgium

Telephone: 32 (0) 85 274080
Fax: 32 (0) 85 274081
e-mail: sales@eurotherm-belgium.be
<http://www.eurotherm.nl>

Denmark

Eurotherm Danmark A/S
Finsensvej 86,
DK 2000 Fredriksberg,

Telephone: +45 (38) 871622
Fax: +45 (38) 872124
e-mail: salesdk@eurotherm.se

Finland

Eurotherm Finland,
Aurakatu 12A,
FIN-20100 Turku

Telephone: 358 2 25 06 030
Fax: 358 2 25 03 201

France

Eurotherm Automation Division Chessell
Parc d'Affaires,
6, Chemin des Joncs,
BP55
F - 69574 Dardilly, CEDEX

Telephone: 33 0 4 78 66 55 20
Fax: 33 0 4 78 66 55 35
e-mail: chessell@automation.eurotherm.co.uk
<http://www.eurotherm.tm.fr>

Germany

Eurotherm Deutschland GmbH
Ottostraße 1,
65549 Limburg

Tel: +49 (0) 64 31/2 98 - 0
Fax: +49 (0) 64 31/2 98 - 1 19
e-mail: info@regler.eurotherm.co.uk
<http://www.eurotherm-deutschland.de>

Great Britain

Eurotherm Limited,
Faraday Close,
Worthing,
West Sussex BN13 3PL

Telephone: +44 (0)1903 695888
Fax: +44 (0)1903 695666
e-mail: Sales@recorders.eurotherm.co.uk
or: Support@recorders.eurotherm.co.uk
<http://www.eurotherm.co.uk>

Hong Kong

Eurotherm Limited,
Unit D, 18/F Gee Chang Hong Centre,
65, Wong Chuk Hang Road,
Aberdeen.

Telephone: 852 2873 3826
Fax: 852 2870 0148
e-mail: eurotherm@eurotherm.com.hk

India

Eurotherm DEL India Limited,
152, Developed Plots Estate,
Perungudi,
Chennai 600 096,

Telephone: 91 44 4961129
Fax: 91 44 4961831
e-mail: info@eurothermdel.com
<http://www.eurothermdel.com>

Italy

Eurotherm SpA,
Via XXIV Maggio,
I-22070 Guanzate,
Como.

Telephone: 39 031 975111
Fax: 39 031 977512
e-mail: info@eurotherm.it
<http://www.eurotherm.it>

Korea

Eurotherm Korea Limited,
J- Building
402-3
Poongnab-Dong,
Songpa-Ku
Seoul, 138-040

Telephone: 82 2 478 8507
Fax: 82 2 488 8508

Netherlands

Eurotherm BV,
Genielaan 4,
2404CH Alphen aan den Rijn,
The Netherlands

Telephone: 31 172 411 752
Fax: 31 172 417 260
e-mail: Sales@eurotherm.nl
<http://www.eurotherm.nl>

Norway

Eurotherm A/S,
Vollsveien 13D
1366 Lysaker,
Postboks 227
NO-1326 Lysaker
Norway,

Telephone: 47 67 592170
Fax: 47 67 118301
<http://www.eurotherm.no>

Spain

Eurotherm España SA,
Pol. Ind. De Alcobendas,
Calle de la Granja 74,
28108 Alcobendas,
Madrid.

Telephone: 34 91 661 60 01
Fax: 34 91 661 90 93
<http://www.eurotherm.es>

Sweden

Eurotherm AB,
Lundavägen 143,
S-21224 Malmö.

Telephone: 46 40 38 45 00
Fax: 46 40 38 45 45
e-mail: info@eurotherm.se
<http://www.eurotherm.se>

Switzerland

Eurotherm Produkte (Schweiz) AG,
Schwerzistraße, 20,
CH-8807 Freienbach.

Telephone: 41 55 415 44 00
Fax: 41 55 415 44 15
e-mail: epsag@eurotherm.ch
<http://www.eurotherm.ch>

United States of America

Eurotherm Recorders Inc.
741-F Miller Drive
Leesburg
VA 20175-8993

Telephone: 1 703 669 1342
Fax: 1 703 669 1307
e-mail (Sales): sales@chessell.com
e-mail (Technical): support@chessell.com
<http://www.chessell.com>



invensys
EUROTHERM

EUROTHERM LIMITED

Faraday Close, Durrington, Worthing, West Sussex, BN13 3PL
Telephone: 01903 695888 Facsimile: 01903 695666
e-mail: info@eurotherm.co.uk
Website: <http://www.eurotherm.co.uk>

