

Atmosphere Sensors



Atmosphere Sensors

Oxygen Probe



Series AP
In-Situ % Oxygen Probe
for
Carbon Control System

Introduction

The Series AP In-Situ Carbon Sensor is a direct and continuous carbon potential sensor. It provides measurement accuracy of .05% of carbon over the temperature range of the sensor. Its unique patented design features a cylinder of special zirconium oxide formulation, welded into the end of an alumina tube by means of an eutectic welding process. The resultant homogenous structure provides the most rugged element design. The superstructure is of high temperature special alloy with a flow through tip design which minimizes soot collection. Internal connections are protected by a high quality connecting head. External connections are made with a quick disconnect four pin plug.

The probe can measure very low oxygen partial pressures with extreme accuracy and repeatability. It will control furnace atmospheres and generator gas supplies over the full range of carburizing hardening applications.

Energy Cost Savings

The furnace can be raised to operating conditions more rapidly and better control maintained after loading, resulting in economical energy savings. The carburizing gas supply is used more efficiently, resulting in increased savings. Furnace burnout of carbon deposits is either reduced or eliminated. Leakage of furnace seals or firing tubes is easily detected to make repairs and improve furnace efficiency.

Maintenance

The Series AP Probe does not require frequent maintenance and cleaning. When cool, it can be cleaned with a soft brush. No calibration is required. The only part subject to wear is the outer electrode which can be renewed at the factory. A special purge fitting allows soot burn-off in the furnace.

Operation

Two electrodes make contact with the platinum coated zirconia element at the tip of the sensor: one outer electrode, and one inner electrode.

The special alloy protection tube is one conductor for the carbon probe signal. This eliminates the need for a small signal wire normally exposed to the furnace environment. The protection tube has excellent resistance to corrosion and oxidation at high temperature, good mechanical strength, and is not affected by hydrogen embrittlement.

The AP Probe is suitable for high temperature carburizing heat treating, carbonitriding and endothermic gas generators *-not* for nitriding applications.

Zirconia is a solid state electrolyte which conducts oxygen ions at temperatures above 1400°F. The ion conduction results in a voltage between the two electrodes. The magnitude of the voltage depends on the temperature of the zirconia, and on the ratio of the oxygen

Oxygen Probe

Introduction (continued)

partial pressure on the reference side of the electrolyte to the oxygen partial pressure on the process side of the electrolyte.

Probe Vdc = $0.0215 \times T_k \times \ln O_1/O_2$ where: probe Vdc = sensor output in mV;
 T = sensor temperature in degrees Kelvin;
 O₁ = concentration on inside surface of the sensor - namely, ambient air which is 20.9% oxygen;
 O₂ = concentration on outside surface of the sensor - namely furnace atmosphere.

Two connections to the zirconia cell conduct the voltage to the four pin connector.

Specifications

Output Readout	1.00 to 1.20 Vdc over operating range. % carbon sensor should be used with controlling, recording, and indicating instruments that have input impedance of 8 M or higher.
Immersion Depth	Three inches minimum.
Thermal Shock	The special alloy protection tube acts as a heat sink that allows the alumina tube inside to change temperature at a slow rate.
Mechanical Shock	The protection tube is not subject to mechanical shock. The alumina tube inside has fair resistance to mechanical shock.
Weight	Three pounds, five ounces (21" length).
Accuracy	±0.05 weight percent carbon in normal operating range.
Response Time	Less than 1.0 second.
Reference Air	Uncontaminated air at recommended rate of 236 cc per minute (.5 cubic feet per hour).
Protection Tube	Special alloy is resistant to corrosion and oxidation up to 2012°F (1100°C). Very good mechanical strength.
Operating Temperature	1400°F (760°C) to 2012°F (1100°C).
Thermocouple	Types K, R and S.
Air Purge Fitting	Allows connection of low flow (approximately 1 CFH) air supply to burn off accumulated carbon in probe.

Endothermic Atmospheres

Millivolt readings for endothermic atmospheres generated from methane (natural gas) and containing approximately 20% CO + C₂

%Carbon	1400°F (760°C)	1500°F (815°C)	1600°F (871°C)	1700°F (927°C)	1800°F (982°C)	1900°F (1038°C)	2000°F (1093°C)
0.10			1016	1021	1027	1035	1043
0.30		1059	1067	1077	1087	1099	1110
0.50		1084	1095	1106	1118	1131	1144
0.70	1092	1103	1115	1127	1141	1154	1168
0.90		1118	1131	1144	1158	1172	1187
1.10			1145	1159	1173	1188	1203
1.25				1168	1183	1198	1214
1.40					1193	1208	1224

Notes:

- Carbon absorption and diffusion rates limit the actual level attainable on the steel work surface. Carburizing time and temperature and steel composition affect the relationship between atmospheric carbon potential and resultant surface carbon level. Specific conditions such as shorter carburizing cycles, may necessitate controlling at a carbon potential as much as 0.25 wt. %C higher than required on the work.
- This chart pertains only to endothermic base atmospheres generated from predominantly methane - i.e., 20% (CO + CO₂).
- Controlling carbon potential at a level exceeding the carbon content of saturated austenite is discouraged.
- Complete table is supplied with each probe. Other % (CO + CO₂) tables available. The Series AC Controllers provide direct readout and control in % carbon when used with the AP probe.

Oxygen Probe

Specifications (continued)

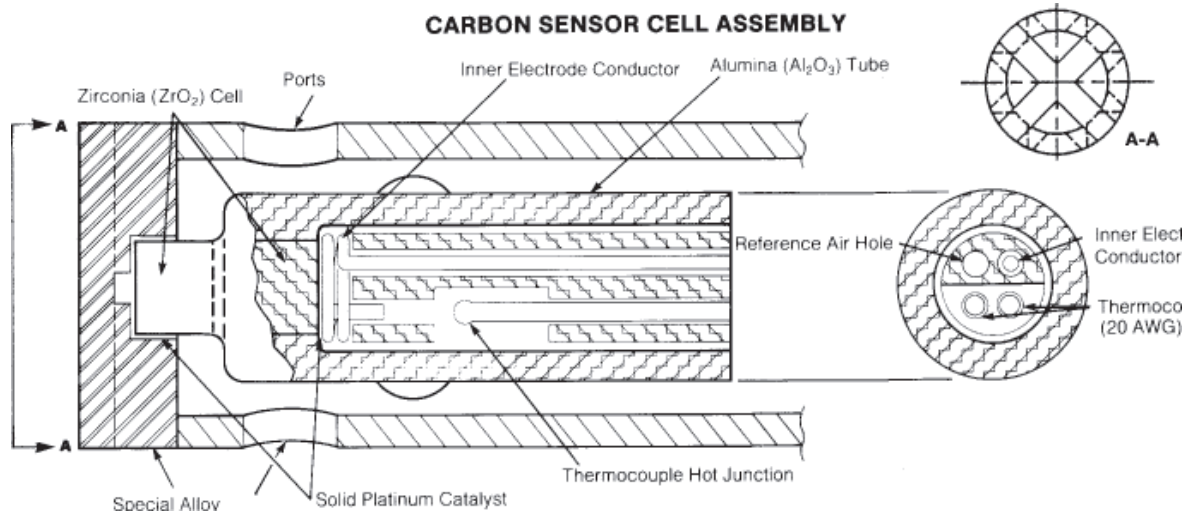

Atmosphere Sensors

Oxygen Probe

Ordering Information

Model No. AP1□-001□□-4□1-1-00
 Field No. 1 2 3 4 5 6 7 8 9 10 11 12 13 14 15

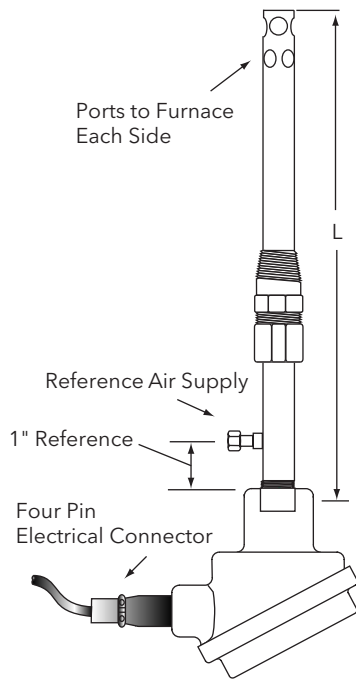

Fields 1, 2, 3. BASE MODEL
 AP1 - Oxygen probe

Field 4. THERMOCOUPLE TYPE
 1 - Type K
 2 - Type R
 3 - Type S

Fields 5, 6, 7. RESERVED

Fields 8, 9. LENGTH (DIMENSION "L")
 21 - 21" probe, Type K
 21" probe, Type R or Type S
 LL - Length in whole inches (22" minimum; 41" maximum)

Field 10. RESERVED

Field 11. CABLE
 0 - Six feet, no armor
 1 - Six feet, with armor
 2 - No cable, see models A-10727 and A-12237 on accessories page for cables longer than six feet

Fields 12, 13, 14, 15. RESERVED

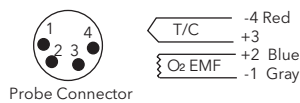

Atmosphere Sensors

Oxygen Probe

General Purpose In-Situ Oxygen Probe
for
Medium Reduction, Neutral or Oxidizing Atmospheres to 3000°F (1649°C)



Introduction

The Series AP In-Situ Oxygen Sensor is a direct and continuous carbon potential sensor. It provides measurement accuracy of 0.5% of oxygen over the temperature range of the sensor. Its unique patented design features a cylinder of a special zirconium oxide formulation, welded into the end of an alumina tube by means of an eutectic welding process. The resultant homogenous structure provides the most rugged element design, and is resistant to thermal shock. The superstructure is of high temperature alumina. Internal connections are protected by a high quality connecting head. External connections are made with a quick disconnect four pin plug.

Above 1300°F, a voltage is generated from the ionic migration through the solid zirconium electrolyte when there is a difference in oxygen concentration on each side of the sensor. The sensor reacts instantaneously to changes in oxygen level and becomes increasingly more sensitive as the oxygen in the process decreases. The probe can measure very low oxygen partial pressures with extreme accuracy and repeatability. This enables the probe to sense atmospheres and allow the controller to control the atmosphere at maximum efficiency.

The Series AP Probe does not require frequent maintenance and cleaning. When cool, it can be cleaned with a soft brush. No calibration is required. The only part subject to wear is the outer electrode which can be renewed at the factory.

Specifications

Output:	See tables on next page
Readout Impedance:	Percent oxygen sensors should be used with controlling, recording and indicating instruments having input impedances of 10 M Ω or higher
Accuracy:	± 0.2 PPM oxygen at 1 PPM oxygen. $\pm 1\%$ of full scale mV output
Response Time:	Less than one second
Thermocouples:	Types K, B, R and S
Operating Temperature:	1300°F (704°C) to 3000°F (1649°C)
Protection Tube:	Alumina. Resistant to corrosion and oxidation up to 3000°F (1649°C)
Thermal Properties:	Withstands temperature up to 3100°F. Will withstand thermal gradients, but is more sensitive to thermal shock
Mechanical Shock :	Resists mild mechanical shock. Handle carefully
Immersion Depth:	Three inches minimum
Reference Air:	Uncontaminated air at a maximum rate of 236 cc per minute = five cubic feet per hour = .5 SCFH

Oxygen Probe

Specifications (continued)

Millivolt output as a function of temperature vs. percent oxygen:

$$E(\text{mV}) = 0.0215 \times T^{\circ}\text{K} \times \ln \frac{20.95\% \text{ O}_2}{\text{Sample O}_2}$$

% Oxygen	Temperature									
	1300°F (704°C)	1400°F (760°C)	1500°F (816°C)	1600°F (871°C)	1700°F (927°C)	1800°F (982°C)	1900°F (1038°C)	2000°F (1093°C)	2100°F (1149°C)	
.0001	257.5	272.1	286.8	301.4	316.0	330.7	345.3	359.9	374.6	
.0005	223.7	236.4	249.1	261.8	274.5	287.2	299.9	312.7	325.4	
.0010	209.1	221.0	232.9	244.8	256.6	268.5	280.4	292.3	304.2	
.0050	175.3	185.2	195.2	205.2	215.1	225.1	235.0	245.0	255.0	
.0100	160.7	169.8	179.0	188.1	197.2	206.4	215.5	224.6	233.8	
.0500	126.9	134.1	141.3	148.5	155.7	162.9	170.2	177.4	184.6	
.1000	112.3	118.7	125.1	131.5	137.9	144.2	150.6	157.0	163.4	
.5000	78.5	83.0	87.4	91.9	96.3	100.8	105.3	109.7	114.2	
1.0000	63.9	67.6	71.2	74.8	78.5	82.1	85.7	89.4	93.0	
5.0000	30.1	31.8	33.5	35.2	37.0	38.7	40.4	42.1	43.8	
10.0000	15.5	16.4	17.3	18.2	19.1	20.0	20.8	21.7	22.6	
20.0000	1.0	1.0	1.1	1.1	1.2	1.3	1.3	1.4	1.4	
	Temperature									
	2200°F (1204°C)	2300°F (1260°F)	2400°F (1316°C)	2500°F (1371°C)	2600°F (1427°C)	2700°F (1482°C)	2800°F (1538°C)	2900°F (1593°C)	3000°F (1649°C)	
.0001	389.2	403.8	418.5	433.1	447.7	462.4	477.0	491.6	506.3	
.0005	338.1	350.8	363.5	376.2	388.9	401.6	414.4	427.1	439.8	
.0010	316.1	327.9	339.8	351.7	363.6	375.5	387.4	399.3	411.1	
.0050	264.9	274.9	284.9	294.8	304.8	314.7	324.7	334.7	344.6	
.0100	242.9	252.1	261.2	270.3	279.5	288.6	297.7	306.9	316.0	
.0500	191.8	199.0	206.2	213.4	220.6	227.9	235.1	242.3	249.5	
.1000	169.8	176.2	182.5	188.9	195.3	201.7	208.1	214.5	220.8	
.5000	118.7	123.1	127.6	132.0	136.5	141.0	145.4	149.9	154.3	
1.0000	96.6	100.3	103.9	107.5	111.2	114.8	118.4	122.1	125.7	
5.0000	45.5	47.2	48.9	50.6	52.4	54.1	55.8	57.5	59.2	
10.0000	23.5	24.4	25.3	26.1	27.0	27.9	28.8	29.7	30.6	
20.0000	1.5	1.5	1.6	1.6	1.7	1.8	1.8	1.9	1.9	

Oxygen Probe

Specifications (continued)

Oxygen Sensor Cell Assembly

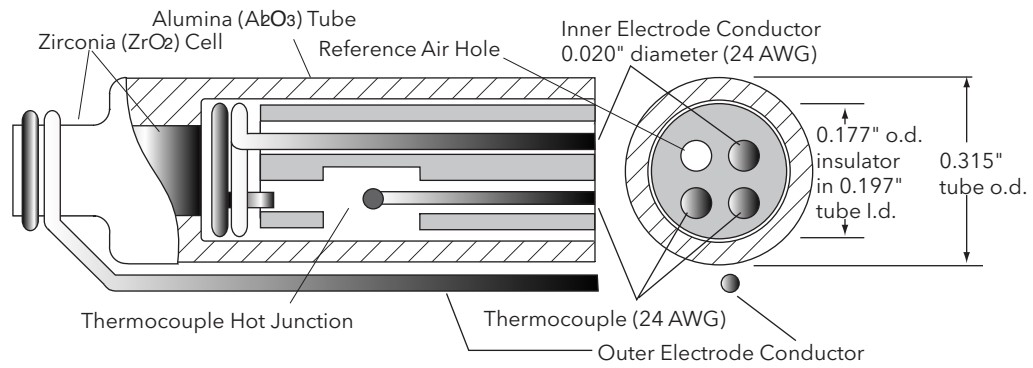

Brick Kiln Control

As the brick cars travel through the tunnel kiln, they pass through oxidizing (excess air) and reducing (excess fuel) stages. A panel of Model OC Series controllers and their associated AP3 oxygen probes can control the entire range of air values.



Atmosphere Sensors

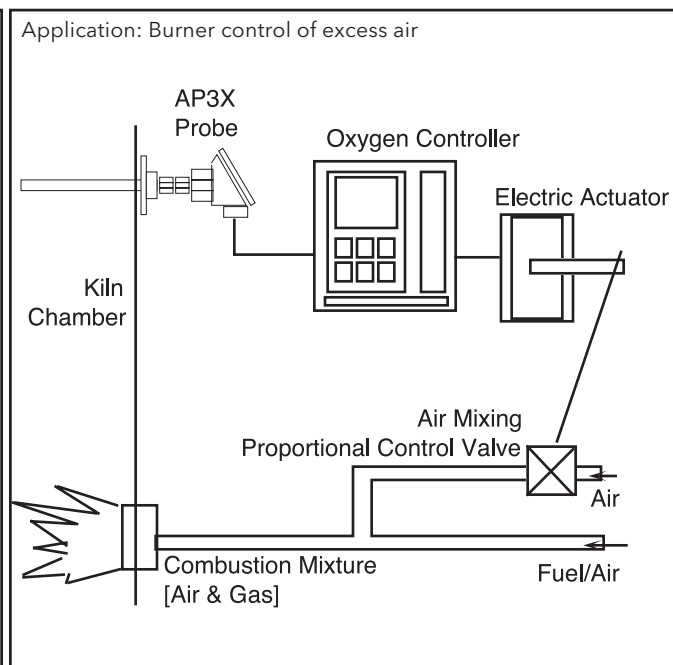
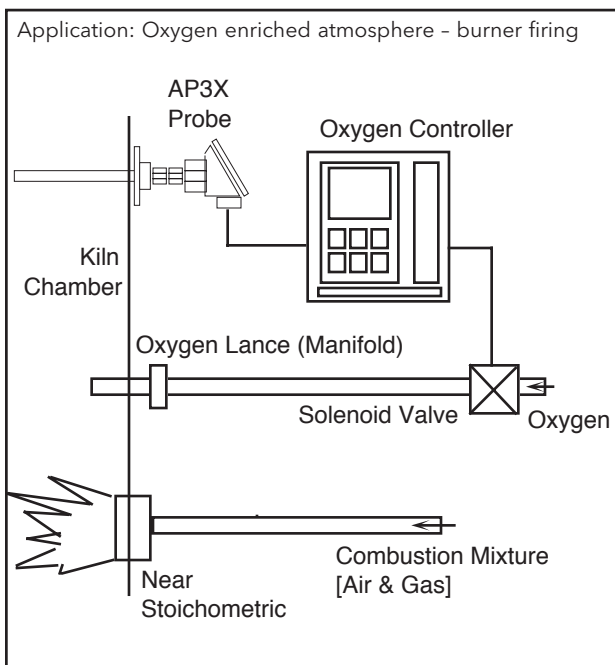

Oxygen Probe

Ordering Information

Model No. AP3 - 001 - 2 0 - 1 - 00
 Field No. 1 2 3 4 5 6 7 8 9 10 11 12 13 14 15

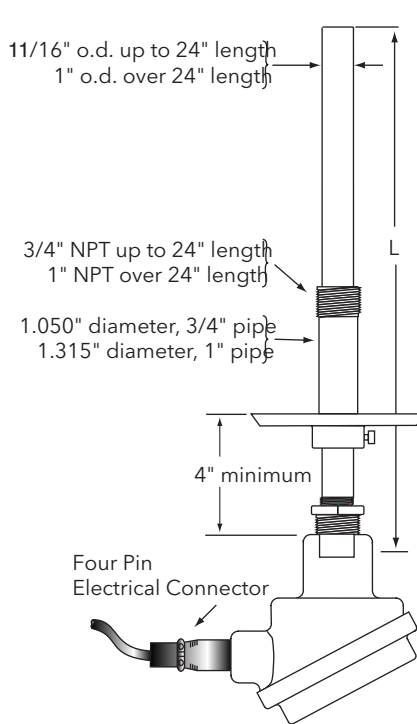

Fields 1, 2, 3. BASE MODEL

AP3 - Oxygen probe

Field 4. THERMOCOUPLE TYPE

- 1 - Type K (2000°F maximum)
- 2 - Type R (2700°F maximum)
- 3 - Type S (2700°F maximum)*
- 4 - Type B (3000°F maximum)

*not offered as standard range option on the Model OC oxygen controller.
 Available on the controller only as special order.

Fields 5, 6, 7. RESERVED

Fields 8, 9. LENGTH (DIMENSION "L")

- 21 - 21" probe, Type K
- 21 - 21" probe, Type R, S, or B
- LL - Length in whole inches (22" minimum; 41" maximum)

Field 10. RESERVED

Field 11. CABLE

- 0 - Six feet, no armor
- 1 - Six feet, with armor
- 2 - No cable, see models A-10727 and A-12237 on accessories page for cables longer than six feet.

Fields 12, 13, 14, 15. RESERVED

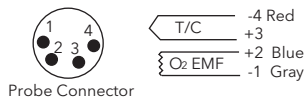

Atmosphere Sensors

Accessories

Accessories

PF70- C0800-067-0-00 1" NPT adjustable process mounting fitting
 X-03201-000-0-00 Air supply hose

Cable Assemblies

A-10727-200-0-XX Type K cable assembly with flexible armor
 A-10727-300-0-XX Type R or S cable assembly with flexible armor
 A-10727-400-0-XX Type B cable assembly with flexible armor
 A-12237-200-0-XX Type K cable assembly without flexible armor
 A-12237-300-0-XX Type R or S cable assembly without flexible armor
 A-12237-400-0-XX Type B cable assembly without flexible armor
 XX = cable length in feet

Reference Air Supplies, Single Output

A-13893-000-0-00 120 Vac, 50/60 Hz., panelmount
 A-13893-000-1-00 120 Vac, 50/60 Hz., with housing
 A-13893-000-0-01 240 Vac, 50/60 Hz., panelmount
 A-13893-000-1-01 240 Vac, 50/60 Hz., with housing

Reference Air Supplies, Dual Output

A-13893-100-0-00 120 Vac, 50/60 Hz., panelmount
 A-13893-100-1-00 120 Vac, 50/60 Hz., with housing
 A-13893-100-0-01 240 Vac, 50/60 Hz., panelmount
 A-13893-100-1-01 240 Vac, 50/60 Hz., with housing

Reference Air Supplies, Reference & Purge Output

A-13893-200-0-00 120 Vac, 50/60 Hz., panelmount
 A-13893-200-1-00 120 Vac, 50/60 Hz., with housing
 A-13893-200-0-01 240 Vac, 50/60 Hz., panelmount
 A-13893-200-1-01 240 Vac, 50/60 Hz., with housing

Reference Air Supplies, Reference & Purge Output, with Metric Flow Gauges, CE

A-13893-400-0-00 120 Vac, 50/60 Hz., panelmount
 A-13893-400-1-00 120 Vac, 50/60 Hz., with housing
 A-13893-400-0-01 240 Vac, 50/60 Hz., panelmount
 A-13893-400-1-01 240 Vac, 50/60 Hz., with housing

Reference Air Supplies, Single Output, with Metric Flow Gauge, CE

A-13893-500-0-00 120 Vac, 50/60 Hz., panelmount
 A-13893-500-1-00 120 Vac, 50/60 Hz., with housing
 A-13893-500-0-01 240 Vac, 50/60 Hz., panelmount
 A-13893-500-1-01 240 Vac, 50/60 Hz., with housing

Air Supply

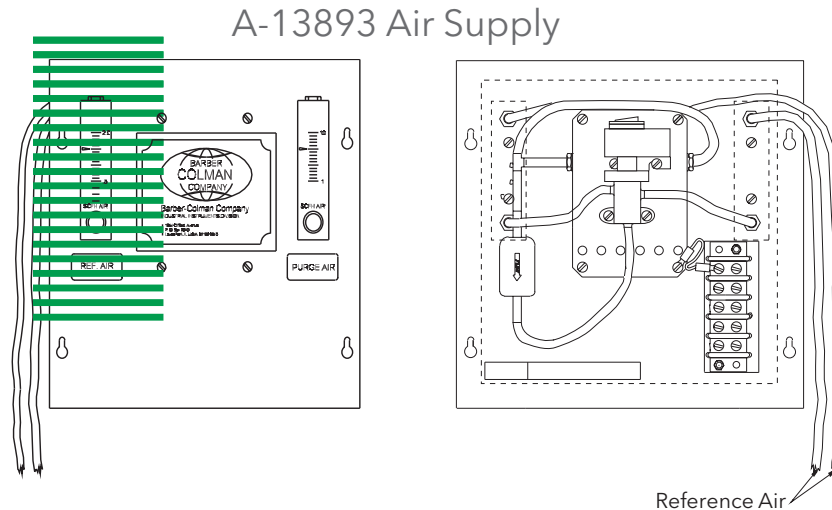

Introduction

The A-13893 Series of air supplies is designed to provide reference and purge air for the AP Series of Carbon and O₂ probes. All models use a rugged double-diaphragm pump designed for an industrial environment. The flow gauges have two-inch scales for readability and easy adjustment. A replaceable filter prevents particulate infiltration of the supply lines. Models are available with a complete housing for surface mounting or with a front panel only for sub-panel installation into a control panel. All versions are 50/60 Hz at 28 Watts.

Ordering Information

Model No. A - 1 3 8 9 3 - - -

Field No. 1 2 3 4 5 6 7 8 9 10 11 12

A-13893-000-x-xx has a single output with a 0-2 SCFH flow meter for use as a reference air supply for a single probe.

A-13893-100-x-xx has dual outputs with 0-2 SCFH flow meters for use as a reference air supply for two probes.

A-13893-200-x-xx has one output for reference air and a second solenoid activated output with a 0-10 SCFH flow meter for purge air.

A-13893-400-x-xx has one output with a 0.06-0.50 LPM flow meter for reference air and a solenoid activated output with a 0.15-1.00 LPM flow meter for purge air.

A-13893-500-x-xx has single output with a 0.06-0.50 LPM flow meter for use as a reference air supply for a single probe.

Fields 1-6. BASE MODEL

A-13893 - Air Supply

Field 7. OPTIONS

- 0 - Single Sensor without Burnoff Option
- 1 - Dual Sensors without Burnoff Option
- 2 - Single Sensor with Optional Remote Burnoff Solenoid
- 4 - Single Sensor with Optional Remote Burnoff Solenoid (International Model)
- 5 - Single Sensor without Burnoff Option (International Model)

Field 10. HOUSING

- 0 - Front Panel Assembly Only
- 1 - Complete Housing Assembly

Field 11. LABEL

- 0 - Barber-Colman Label
- 1 - Eurotherm Label

Field 10. VOLTAGE

- 0 - 120 Vac, 50/60 Hz
- 1 - 240 Vac, 50/60 Hz

The Impressor

The Impressor Hand-Held Portable Hardness Tester

- Aluminum
- Aluminum Alloys
- Soft Metals
- Plastics
- Fiberglass



Introduction

Portable

The Impressor is a convenient tool for testing the hardness of aluminum, aluminum alloys, copper, brass and other materials including plastics and fiberglass. The instrument is designed for use on fabricated parts and assemblies as well as on raw stock.

Easy to Use

No experience required; can be used in any position and in any space that will allow for the operator's hand. The hardness reading is instantly indicated on the dial, which is divided into one hundred graduations. No waiting, pre-loading or separate measurements.

Lightweight

The impressor weighs only 1 lb. 2 oz. and comes complete with carrying case, adjusting wrench and two spare indenter points, 2 lb. 8oz.

Applications

Three Models Available

GYZJ 934-1 for soft metals such as aluminum and its alloys, brass, copper, and some of the harder plastics and fiberglass. Approximate range 25 to 150 Brinell (10 mm ball 500 kg load). This unit meets American Society for Testing and Materials (ASTM) Standard D-2583.

GYZJ 935 for softer plastics and very soft metals.

GYZJ 936 for extremely soft materials such as lead, linoleum and leather.

Our factory engineers will be glad to recommend the most suitable model upon receipt of sample materials.

Operating Information

The Impressor is best suited for testing homogeneous materials. Materials of granular, fibrous or coarse structure will produce a wide variation in hardness readings because of the small diameter of the indenter point.

For accurate readings, material should be at least 1/32" thick and large enough for a minimum distance of 1/8" in any direction from the indenter point to the edge of the specimen. The testing area should be smooth and free from mechanical damage.

Simply exert a light pressure against the instrument to drive the spring-loaded indenter point into the material. The indenter point must be perpendicular to the surface being tested.

On very soft metals, the highest reading should be used since cold flow permits the spring-loaded indenter point to continue penetration.

The Impressor

Operating Information (continued)

Note: Physical characteristics of very soft materials are such that uniform correlation between different hardness measuring systems cannot be established. For this reason, no conversion curves are offered for the 935 and 936 models. We recommend that impressor hardness limits for each material be established by test.

Recommended Sample Sizes To equalize the variance of the average (GYZJ 934-1)

	Hardness Scale	Reading Variance	Number of Readings	Variance of Average
Homogeneous Material:	20	2.47	9	0.27
	30	2.20	8	0.28
	40	1.93	7	0.27
	50	1.66	6	0.28
	60	1.39	5	0.28
	70	1.12	4	0.28
	80	0.85	3	0.28
Reinforced Plastics:	30	22.4	29	0.77
	40	17.2	22	0.78
	50	12.0	16	0.75
	60	7.8	10	0.78
	70	3.6	5	0.75

Typical Readings of Aluminum Alloys

Alloy and Temper:	1100-0	3003-0	3003H14	2024-0	5052-0	5052H14	6061T6	2024T3
GYZJ 934-1 reading:	35	42	56	60	62	75	80	85

Approximate Conversion Curves for GYZJ 934-1

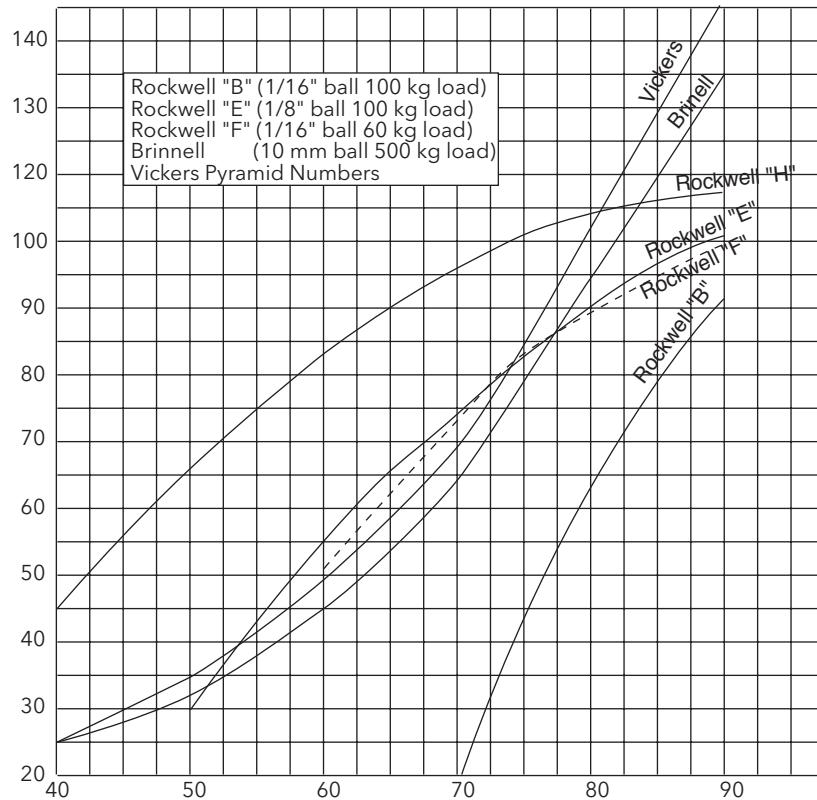

Hardness Tester

The Impressor

Operating Information (continued)

Approximate Conversion Chart for GYZJ 934-1

934-1	Brinnell	Vickers	Rockwell			
			B	E	F	H
35		23				32
36		23				33
37		24				37
38		24				40
39		25				43
40	25	25				45
41	26	26				47
42	26	27				49
43	27	27				52
44	27	28				54
45	27	20				56
46	28	30				58
47	29	32		24		61
48	30	33		25		63
49	31	34		28		64
50	32	35		30		66
51	33	36		33		68
52	34	38		36		70
53	35	39		39	29	72
54	37	41		42	33	73
55	38	42		44	38	75
56	39	44		46	40	76
57	40	45		48	43	78
58	42	47		51	47	80
59	44	48		53	49	81
60	45	49		55	51	83
61	47	51		57	54	84
62	48	53		59	56	86
63	50	55		62	58	88
64	52	57		64	61	89
64	54	58		65	63	90
66	55	60		67	65	91
67	58	62		69	67	92

934-1	Brinnell	Vickers	Rockwell			
			B	E	F	H
68	60	64		71	69	94
69	62	67		73	71	95
70	64	69	18	74	73	96
71	67	72	19	76	75	98
72	69	74	28	77	77	99
73	71	76	33	79	79	100
74	73	81	39	81	81	101
75	76	85	45	83	83	102
76	80	88	48	84	84	103
77	84	92	52	86	86	104
78	87	95	56	88	87	105
89	90	99	60	89	88	106
80	94	103	63	90	89	107
81	97	108	65	91	90	108
82	100	111	69	92	91	108
83	105	116	72	94	92	109
84	109	122	75	95	93	109
85	113	127	77	96	94	110
86	117	133	80	97	95	111
87	122	137	83	98	96	111
88	126	142	86	99	97	112
89	131	144	89	100	97	112
90	135		91	101	98	113
91	139			102	99	113
92	145			103	100	
93				103	101	
94				104	101	
95				104	102	
96				105	102	
97				106	103	
98				107		
99				108		
100				108		

Hardness Tester

Approximate Conversion Chart for GYZJ-935 and GYZJ-936

GYZJ-935 & 936	Type D Durameter	
	GYZJ-935	GYZJ-936
4	64	52
6	65	
8		66
10	67	
12		68
14	69	
16		70
18	71	
20		72
22	73	
24		74
26	75	
28		76

GYZJ-935 & 936	Type D Durameter	
	GYZJ-935	GYZJ-936
30	70	60
32		
34	71	61
36		
38	72	63
40		
42	73	64
44		
46	74	65
48		
50	75	67
52		
54	76	68
56		
	77	69
	78	70
	79	71

GYZJ-935 & 936	Type D Durameter	
	GYZJ-935	GYZJ-936
58	78	72
60	79	73
62		74
64	80	75
66	81	76
68	82	77
70		78
72	83	79
74	84	80
76	85	81
78		83
80	86	84
82	87	85
84	88	86
86	89	87
88	n/a	89

The Impressor

Ordering Information

Hardness Testers	Model	Range
	GYZJ-934-1	25 to 50 Brinell (10 mm ball 500 kg load)
	GYZJ-935	For softer plastic and very soft metals
	GYZJ-936	For extremely soft material

Certified Test Disks	Part No.	Use with Model	Scale	
	GYZJ-069-100	Set of 5	GYZJ-935	87 - 89
	GYZJ-070-100	Set of 5	GYZJ-936	48 - 50
	GYZJ-078-100	Set of 5	GYZJ-934-1	43 - 48
	GYZJ-250-100	Set of 5	GYZJ-934-1	87/89

Non-certified Test Disks	Part No.	Use with Model	Scale	
	GYZJ-069	Each	GYZJ-935	87 - 89
	GYZJ-070	Each	GYZJ-936	48 - 50
	GYZJ-078	Each	GYZJ-934-1	43 - 48
	GYZJ-250	Each	GYZJ-934-1	87/89

The Impressor Repair Parts

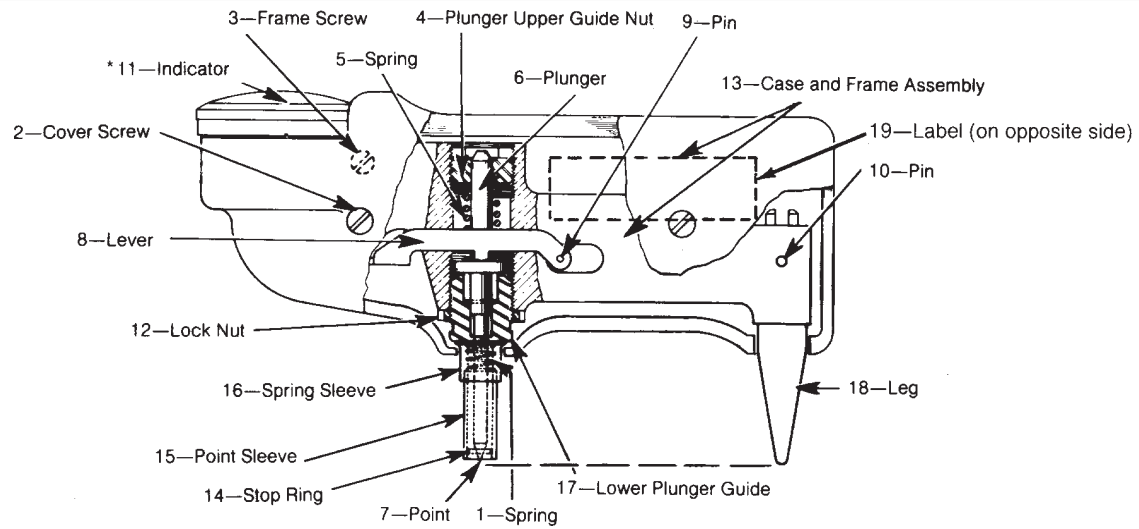

Hardness Tester

Item	GYZJ-934-1	GYZJ-935	GYZJ-936	Description	Qty
1	AYRS-62	AYRS-62	AYRS-62	Spring	1
2	BYRF-3114	BYRF-3114	BYRF-3114	Cover Screw	2
3	BYRF-250	BYRF-250	BYRF-250	Frame Screw	1
4	GYZJ-2	GYZJ-2	GYZJ-2	Plunger Upper Guide Nut	1
5	GYZJ-3	AYRS-146-1	AYRS-146-1	Spring†	1
6	GYZJ-4-1	GYZJ-4-1	GYZJ-4-1	Plunger	1
7	GYZJ-6-5	GYZJ-6-5	GYZJ-67	Indenter Point†	1
8	GYZJ-7	GYZJ-7	GYZJ-7	Lever	1
9	GYZJ-8	GYZJ-8	GYZJ-8	Pin	1
10	DYRA-218	DYRA-218	DYRA-218	Pin	1
11	GYZJ-15-2	GYZJ-15-2	GYZJ-15-2	Indicator (not field servicable)	1
12	GYZJ-16	GYZJ-16	GYZJ-16	Lock Nut	1
-	GYZJ-17-1	GYZJ-17-1	GYZJ-17-1	Wrench	1
-	GYZJ-19-2	GYZJ-19-2	GYZJ-19-2	Carrying Case	1
13	GYZJ-23-1	GYZJ-23-1	GYZJ-23-1	Case & Frame Assembly	1
-	GYZJ-250*	GYZJ-69***	GYZJ-70****	Test Disc†	1
-	GYZJ-78**	None	None	Test Disc†	1
14	GYZJ-61	GYZJ-61	GYZJ-61	Stop Ring	1
15	GYZJ-62	GYZJ-62	GYZJ-62	Point Sleeve	1
16	GYZJ-63	GYZJ-63	GYZJ-63	Spring Sleeve	1
17	GYZJ-64	GYZJ-64	GYZJ-71	Lower Plunger Guide†	1
18	GYZJ-65	GYZJ-65	GYZJ-65	Leg	1
19	GYZJ-79-1	GYZJ-79-2	GYZJ-79-3	Label†	1

†Parts required to convert between models*Marked "87/89" **Marked "43-48" ***Marked "87-89" ****Marked "48-50"



NOTES

Hardness Tester

