

EUROTHERM® FLEXIBLE SOLUTIONS

# Gas Carburising

TREATING STEEL TO IMPROVE SURFACE  
HARDNESS AND DURABILITY

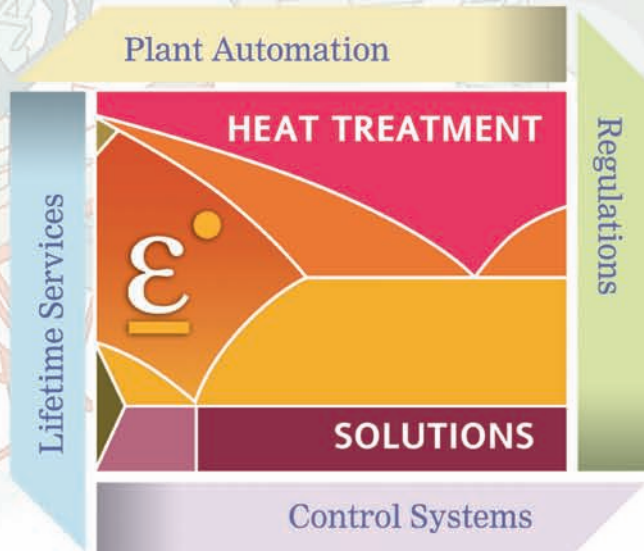
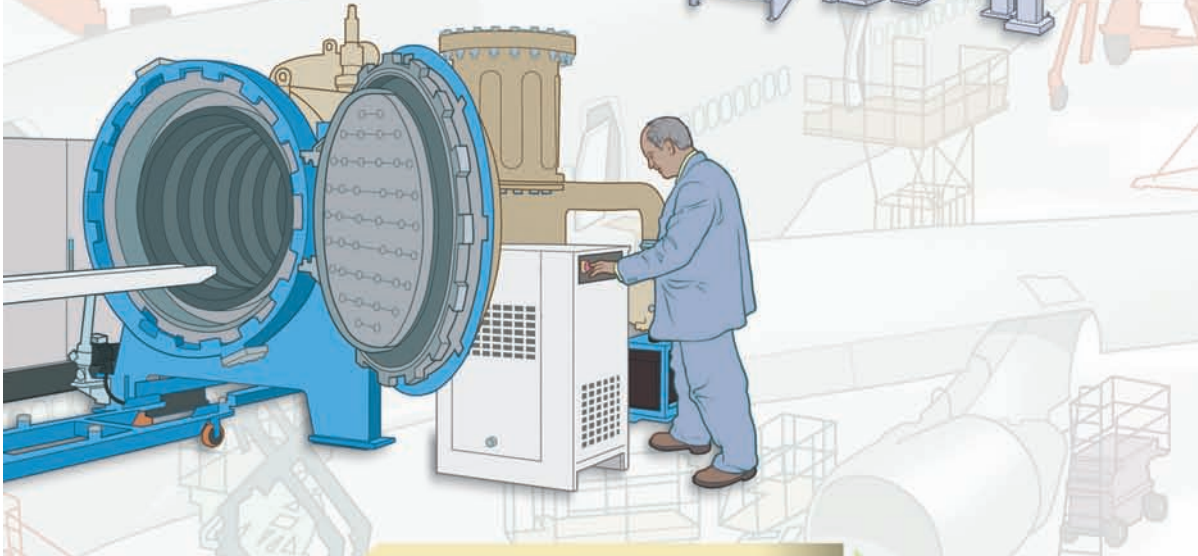
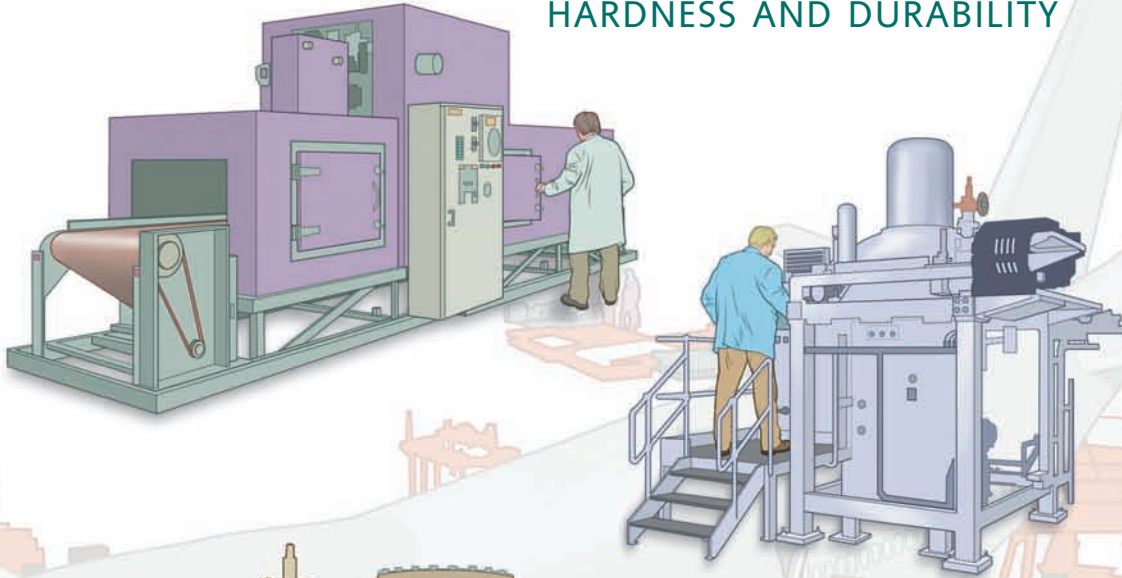

Control Systems

# Building an Atmosphere Furnace Solution

Sealed quench furnaces, continuous carburising furnaces and pit furnaces provide three of the most popular methods for treating low carbon and alloy steels to improve the surface hardness and surface durability of steel-alloy components.

A group of processes are carried out, each of which brings specific benefits to the finished part.

## WHY EUROTHERM?

Eurotherm provides control the building blocks to create and build a high performance furnace control solution including:

- T2550 Programmable Automation Controller (PAC) with distributed I/O
- Eycon™ Visual Supervisor providing a touch screen HMI with strategy engine
- Eurotherm world renowned control algorithms for atmosphere, temperature and quench control
- Advanced carburising atmosphere control strategies using 3 Gas IR spectroscopy and on-line carbon diffusion control
- Off-line simulation package (Carbon Calculator) to enable optimal programming
- Advanced nitriding atmosphere control strategies to control  $K_n$  and  $\%NH_3$

Eurotherm delivers control solutions for continuous and batch gas carburising furnaces to meet stringent regulatory demands including AMS2750 Revision D and TS16949. A Eurotherm solution delivers the user:

- Accurate temperature and carbon setpoint control
- Asynchronous control of heating and quenching cycles
- Carbon diffusion control
- Tamperproof data archiving
- Furnace diagnostics and maintenance
- Gas sequence and mass flow control
- Power control and energy management
- Alarm visualisation and strategy
- Touch screen HMI panel with furnace mimics

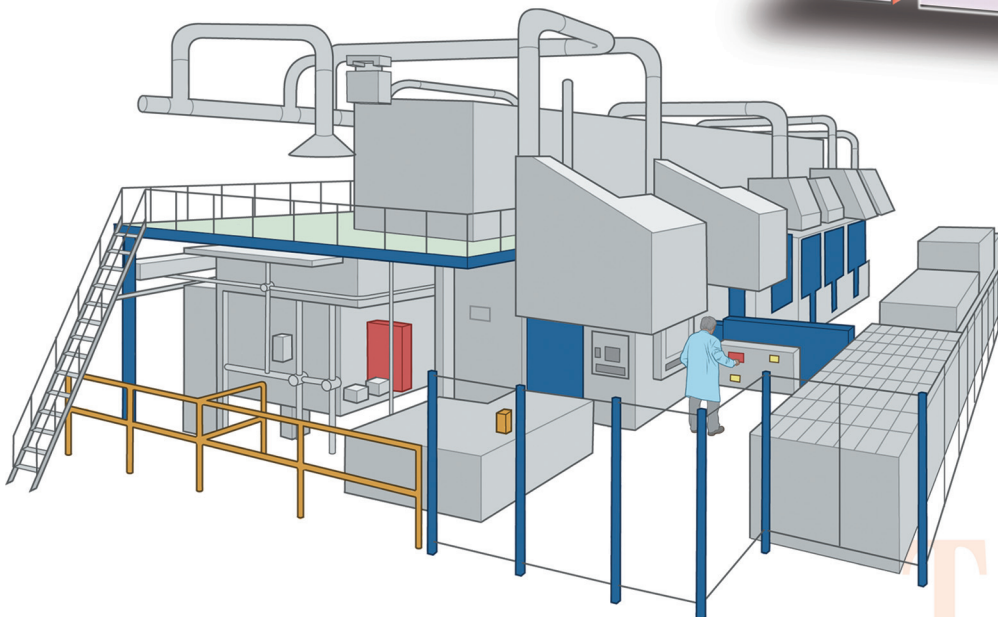

# HEAT TREATMENT

## THE PROCESS

### Gas Carburising

A surface chemistry process, which improves the case depth hardness of a component by diffusing carbon into the surface layer to improve wear and fatigue resistance. The work pieces are pre-heated and then held for a period of time at an elevated temperature in the austenitic region of the specific alloy, typically between 820 and 940°C.

During the thermal cycle the components are subject to an enriched carbon atmosphere such that nascent species of carbon can diffuse into the surface layers of the component. The rate of diffusion is dependent on the alloy and carbon potential of the atmosphere. Care must be taken to ensure that only sufficient carbon is available in the atmosphere at any one time to satisfy the take up rate of the alloy to accept the carbon atoms. In practice this is defined in a carbon potential setpoint profile which runs concurrently with the temperature cycle. The setpoint may give a boost phase where the carbon potential would be typically set above 1.0% carbon but, as the cycle progresses and the effective case depth increases, the carbon setpoint will be reduced to complete the diffusion stage. Depending on the final requirement for effective case depth, the whole cycle may take many hours.

Once the heating and carbon diffusion part of the process are complete it is necessary to rapidly quench the components to a defined alloy recipe. The recipe will specify the quench method, the quench temperature and time. The purpose of the quench process is to provide the required hardness of the component by completing a Martensitic phase change in the alloy.

Gas carburising and other surface chemistry treatments can be carried out in batch or continuous furnaces dependant on the parts under treatment and the user requirements. Eurotherm provides solutions for both types of furnace, as well as other metal treating processes such as:

- Nitriding
- Carbonitriding
- Nitrocarburising
- Tempering
- Stress relieving

### Nitriding

Nitriding is a low distortion thermochemical process conducted at temperatures between 480-560°C. In the case of Nitriding the active gas is often produced by cracking Ammonia in the furnace to release the nascent species of Nitrogen having first purged the furnace with nitrogen.

Nitriding control can be run on the 3504 controller, with output from an external hydrogen sensor. The 3504 displays both Kn (nitriding potential) and dissociated ammonia values, and is able to use either variable to control the nitriding process

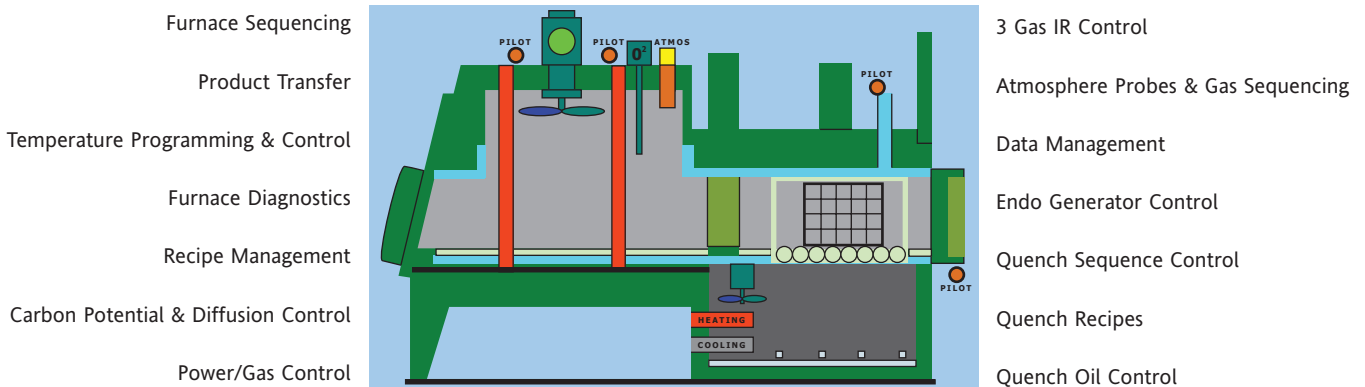

*Typical features of a batch sealed quench furnace*

HEAT TREATMENT  
SIMPLE  
SCALABLE  
ACCURATE



# Building an Atmosphere Furnace Solution

- SIMPLE to build using pre-defined building blocks
- SCALABLE solution fits the requirements of any plant
- The most ACCURATE atmosphere control solution available

## CONTROL SYSTEMS

Thermochemical heat treatments are widely used in the aircraft and automotive industry manufacturing process. Many components such as gears, shafts and bearings, as well as a host of sub-parts, are subject to some case hardening technique and there is a world wide installed base of furnace equipment.

Eurotherm supply a wide variety of control solutions in to batch and continuous carburising furnace applications. The scope of supply may vary but there are some key common requirements:

- Temperature programming and control
- Atmosphere (Carbon Potential) programming and control of case depth diffusion control
- Atmosphere probes and atmosphere probe diagnostic features
- Gas control (sequence and mass flow control) for some specific applications
- Quench programming and control
- Furnace sequence control
- Furnace safety alarms
- Recipe control and programme management
- Data management
- Power control and energy management
- Furnace diagnostics and maintenance
- Furnace mimics and screen navigation

## Furnace Temperature Control and Programming

Optimum temperature control is achieved using an independent furnace sensor. The heat control output can either be connected to gas burners or thyristors. In some applications a cooling output may also be connected to a circulation fan or an exhaust damper.

It is normal for many instances of the furnace programme to be available for operator selection against a component or batch reference.

Password protected multi-segment programmers enable an optimum profile to be achieved with full traceability.

## Furnace Atmosphere Control

A zirconia probe is used to measure very low concentrations of % oxygen in the furnace, typically less than  $1 \times 10^{-20}$ . To supply the required species carbon it is usual for the furnace to be supplied with a base endothermic carrier gas which conditions the furnace, at say 20% CO for a methane based carrier gas. In the atmosphere loop, the controller uses the carbon potential calculation based on the known oxygen reading to increase the carbon potential by allowing additional carburising gas (ie methane) to enter the furnace. Conversely, to decrease the carbon potential, controlled air is introduced into the furnace. Automatic probe cleaning functions ensure that the reading is accurate, while probe health and sooting alarms warn of a deterioration in the probe performance.

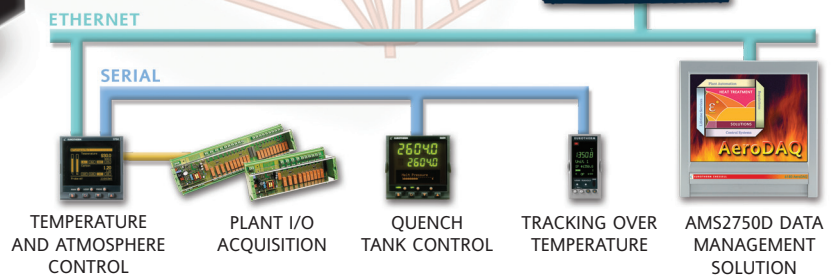

*Typical discrete control solution*

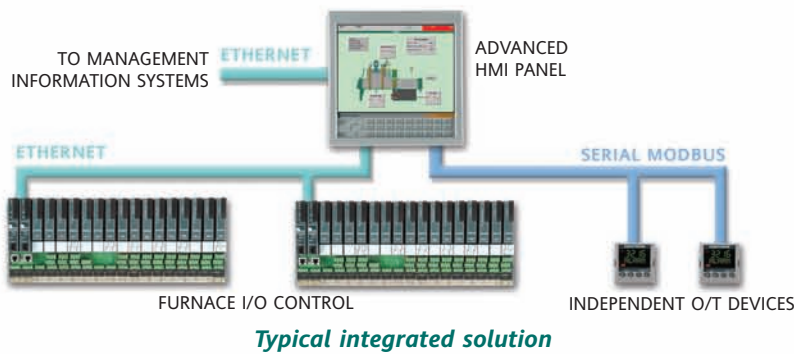

### 3 Gas IR Control

The Carbon potential calculation using an oxygen probe is based on furnace gas equilibrium conditions. Equilibrium conditions rarely exist during short or medium carburising cycles. As a consequence atmosphere carbon potential, based on an oxygen probe, is often overstated. Furthermore and more importantly, the carbon potential is only calculated from a single gas constituent, the oxygen content of the furnace atmosphere, and a **fixed value** for the carrier gas CO.

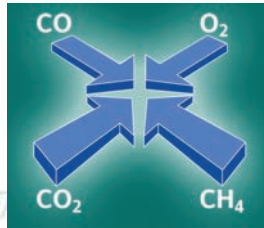

### Diffusion Control

Traditionally carburising is carried out against a timed setpoint profile where the time periods for the different temperature/carbon stages are selected against empirical post-process material results.

This method provides a steel/alloy dependent recipe, which gives good repeatable performance but heat treaters tend to process at the high end of the case depth tolerance to ensure good repeatable results.

Since the purpose of the process is to provide components with a defined effective case depth usually with a minimum tolerance other methods, which allow effective case depth to be selected as the controlling setpoint, have become more widely available.

### The solution for optimum accuracy

#### Three gas infrared with automatic probe compensation

A three gas infrared system calculates, with higher accuracy, the carbon potential using furnace realtime CO, CO<sub>2</sub> and CH<sub>4</sub> values. The Infrared system then calculates the Process Factor or CO Factor based on the IR Carbon % and sends this new Process Factor, via a special communications link, to update the Eurotherm atmosphere carbon controller's Process Factor. As a result, the atmosphere controller now reads the same as the calculated IR carbon. The oxygen probe may be sooted or even failing and the infrared system will compensate.

**The system combines the convenience and response of a oxygen probe with the superior accuracy of multi-gas infrared measurement to provide the very best control available.**

#### Benefits

- Accurate calculations of atmosphere carbon potential – Three times more accurate than a probe
- Automatic oxygen probe compensation
- Verification of oxygen probe accuracy and performance
- Easy identification of furnace atmosphere problems and furnace condition
- Reduction of scrap and rework from high accuracy process control and repeatability

The case depth diffusion solution is available as a function block within the Eycon™ Visual Supervisor and uses an algorithm based on carbon potential, temperature, material specification and process factors to determine the carbon setpoint profile.

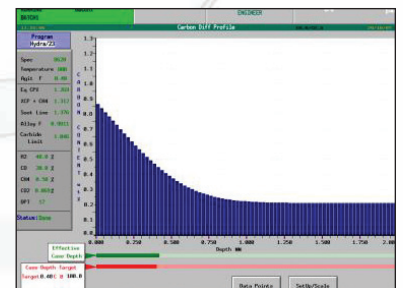

**A typical diffusion cycle**

In this case the traditional recipe hands control to the dynamic on-line diffusion calculation, which completes the carburising cycle to the required effective case depth.

#### Benefits

- Reduced cycle time
- Real time calculation of case depth profile





# Continuous Gas and Batch Carburising Furnace Application

## Atmosphere Probe Diagnostics

### Sooting Alarm

By careful analysis of the furnace temperature and carbon potential it is possible to determine when the atmospheric conditions are such that carbon will be deposited as soot on all surfaces inside the furnace, including the workpiece. It is obviously desirable to avoiding this situation and in Eurotherm solutions an alarm is preconfigured and can be used to trigger a furnace event. Eliminating sooting protects the furnace lining, maintains the accuracy of the zirconia probe and stops formation of a soot barrier on the workpiece, which can prevent carbon diffusion.

### Automatic Probe Cleaning

A probe clean and recovery strategy can be programmed to occur between batches or manually requested by an operator. A short blast of high flow burn off is used to remove any soot and other particles that may have accumulated on the probe. During the cleaning and recovery cycle the %CP reading is frozen, thereby ensuring continuous furnace operation.

### Probe Impedance Monitoring

When the output impedance of a zirconia probe increases above a certain level, it indicates that the performance of the probe has deteriorated and that it should be replaced. Using a specialist zirconia input module the T2550 PAC controllers have the ability to measure the impedance of the sensor connected to its input and, in conjunction with User Alarms, an alarm strategy can be created to alert an operator of an impending probe failure. This feature can be retrofitted into existing installations where the customer is happy with the carbon control system but wishes to provide additional probe diagnostics.

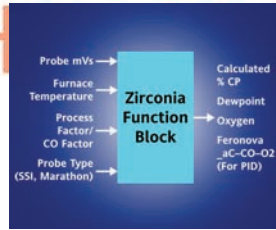

SEQUENT	TEMP (°C)	TEMP. TIME	SMELL. TIME	COMPLETED TIME	CARBON OF TEE	SIZE DEPTH	CONTROL	TRACK
SMELL	9275	03	050	1.03	1.20	035	NO	PROBE CLEAN
SMELL	9275	03	050	1.03	0.00	995	NO	PROBE CLEAN
END	91818	03	1.03	1.03	0.50	1.018	NO	PROBE CLEAN
03	03	03	03	0.00	03	NO	PROBE CLEAN	PROBE COIL
03	03	03	03	0.00	03	NO	PROBE CLEAN	PROBE COIL
03	03	03	03	0.00	03	NO	PROBE CLEAN	PROBE COIL
03	03	03	03	0.00	03	NO	PROBE CLEAN	PROBE COIL
03	03	03	03	0.00	03	NO	PROBE CLEAN	PROBE COIL
03	03	03	03	0.00	03	NO	PROBE CLEAN	PROBE COIL
03	03	03	03	0.00	03	NO	PROBE CLEAN	PROBE COIL

PROGRAMMATIC DATA

Program: Fuel#11	CD Mode:	Aut. Low	0	Temperature PV:	800	Smell Target: 0	
Batch: Ed 07	Skull Spac:	SK 0030	0	Temp. Target SP:	0	Smell Time: 0.0	
Load No.: 0113 Sm	Carbon Target:	0.40	0	Smelt Working SP:	0	Target CP:	1.00
Operator: 0111 Sm	Case Depth:	0.400	0	Smeltch: 1 Smel: 0.0	0.00	Carbon SP:	0.00

HEATING SEQUENCE

Temperature PV:	800	Smell Target: 0	
Temp. Target SP:	0	Smell Time: 0.0	
Smelt Working SP:	0	Target CP:	1.00
Smeltch: 1 Smel: 0.0	Carbon SP:	0.00	

### Quench Control

Quenching of components is an integral and critical part of the process.

The quench recipe, which is normally held as part of the overall process profile, will contain options for Oil or Air quench, the quench oil temperature, time and oil flow circulation speed and direction. The recipe may also include the drip timer setting. Safety measures need to be considered for quench elevator failure position and pressure interlocks between the oil pressure and the oil cooler heat exchanger water pressure.

The control system must be designed to ensure that the thermal/carbon profile and the quench profile can operate asynchronously. This allows one product to be completing its process cycle in the quench tank while a new product is being treated in the furnace.

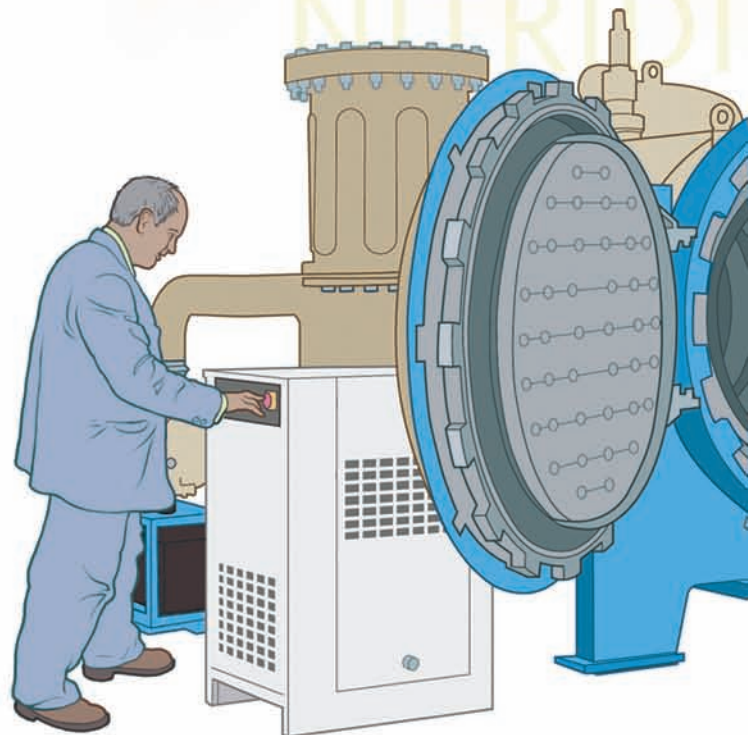

## Carbon Potential Measurement

Accurate measurement of the furnace atmosphere is critical to the application. Normally a zirconia probe is used to measure carbon potential. The zirconia probe generates a millivolt signal based on the ratio of oxygen concentration between the reference airside of the probe (outside the furnace) and the amount of oxygen actually inside the furnace. Temperature is measured using a built in thermocouple at the tip of the probe. An application specific zirconia function block uses the millivolt and temperature signals together to calculate the actual percentage of carbon in the furnace atmosphere. The condition of the probe is again vital to furnace performance and Eurotherm use many techniques to maintain and diagnose the performance of the insitu probe.

## Carbon Calculator

An off-line carbon calculator allows the simulation of furnace profiles on a PC to determine the best fit profile for any batch.

### Benefits

- No disruption to furnace utilisation
- Calculates a choice of:
  - Furnace time
  - Case depth
  - Profile
- Multiple user input variables:
  - Steel specification
  - Furnace temperature
  - Furnace atmosphere
  - Carbon potential
  - Agitation factor

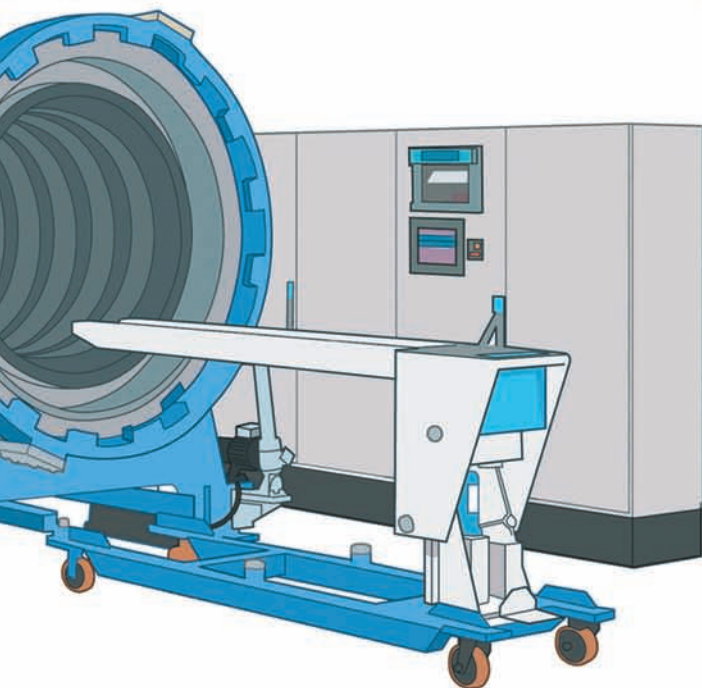

## Carburising Gas Correction

A gas analyser can be used to determine the CO concentration of the carburising gas and fed into the controller to automatically adjust the calculated % carbon reading.

## Gas Sequencing

For Nitro Carburising it is necessary to introduce other gasses, such as species nitrogen, into the furnace during the carburising process. This can be controlled via sequencing or mass flow control.

## Furnace Sequencing Control

The control system needs to cater for or interface with furnace sequencing. The sequencing is required for work-piece transfer through the furnace, cycle control, quench sequencing and burner or energy control. Discrete control solutions tend to interface with an external PLC but, in integrated solutions, it is possible to carry out the entire furnace sequencing in one control environment.

## Furnace Alarms

Alarms are provided for the following:

- Furnace over temperature
- Quench oil over temperature
- Burner system alarm
- Process enabling temperature alarms at 600°C and 750°C
- Probe diagnostic alarms
- Atmosphere out of tolerance alarm
- Furnace fan unbalance alarm (option)
- Quench flow and pressure alarms
- Quench oil heat exchanger flow and pressure alarms



The following thermal chemical processes are also part of the family of surface hardening treatments.





# Tamper Resistant Data Recording and Data Management

Data logging is a key requirement for many carburising applications particularly where processes are associated with either aerospace and automotive quality systems.

Eurotherm control systems include data management products, which meet the most exacting demands of NADCAP and AMS2750D including the following:

- Accurate time and date stamps
- All process data including actual values and demand setpoint profiles
- Selected Recipes
- Product batch information
- Alarms and events
- User login and logout
- User notes and user actions
- Electronic signatures
- All data is saved in write once read only format

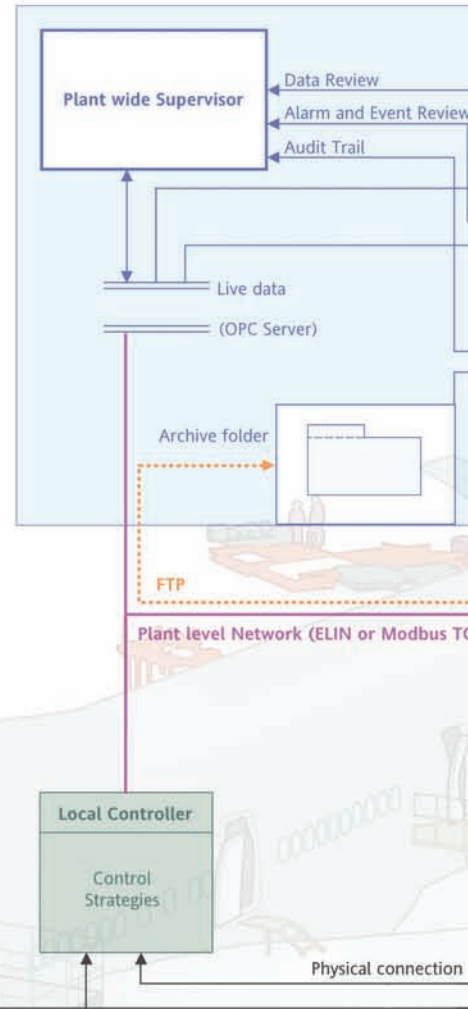
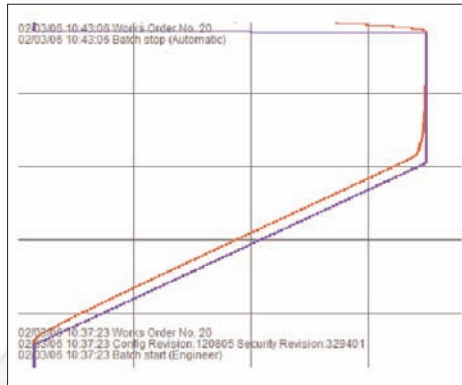

Eurotherm Gas Carburising systems log plant data to tamperproof files and SQL relational databases. Data logging can be offered as:

- Local logging (tamperproof files)
- Central logging (SQL Database)
- Local and Central logging (tamperproof file and SQL Database)

## Data archiving strategies that keep your data safe

Data management solutions from Eurotherm assist with the important task of information housekeeping by providing multiple destination archiving routines.

- Local data backup or remote over Ethernet communications
- Multiple archiving strategies
- Automatic, secure data file backup and transfer routines
- Archive on demand, archive automatically or archive using Eurotherm 'Review' Package
- Multiple archiving destinations, archive to CF/SD, archive to USB memory stick or archive to FTP Server
- Primary and Secondary Server Function

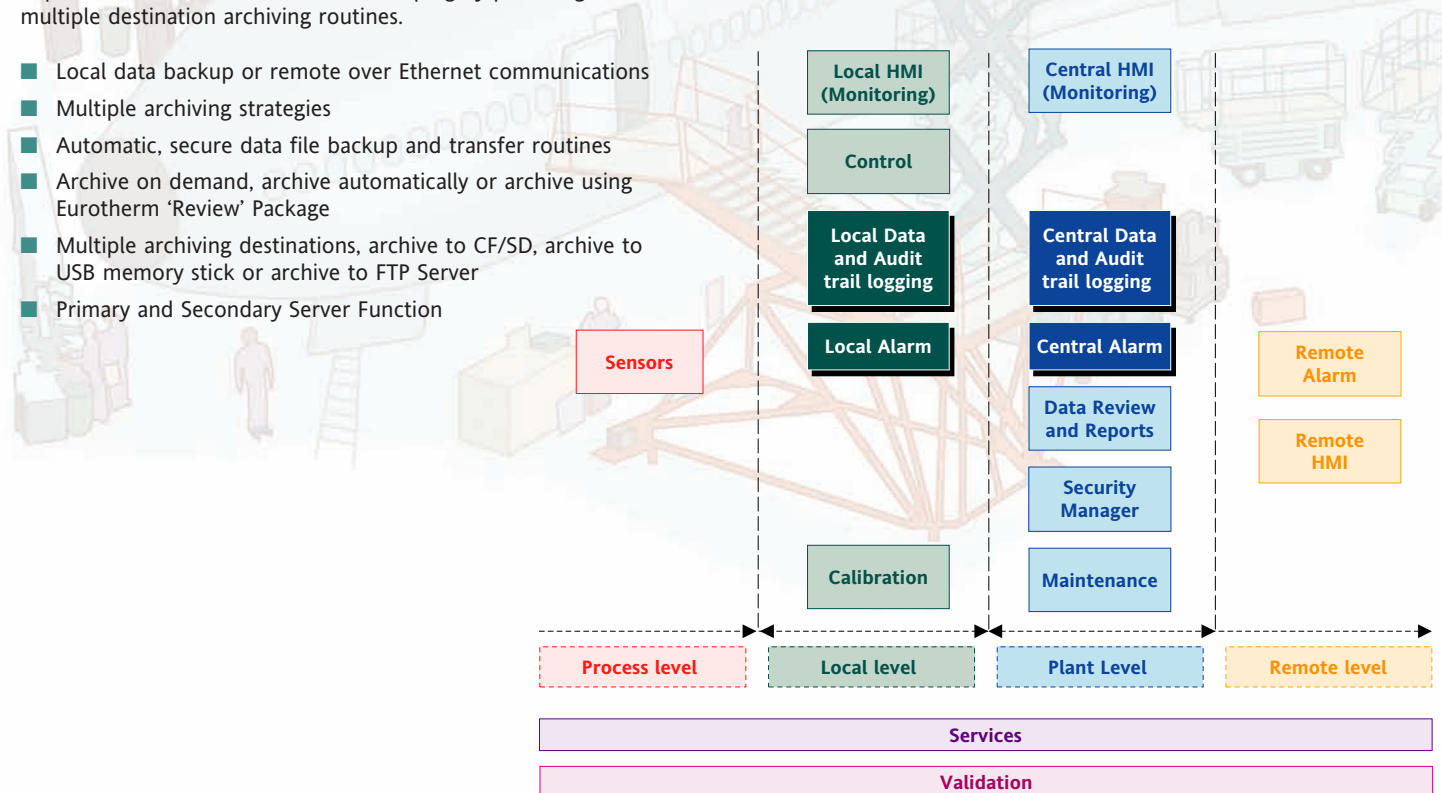



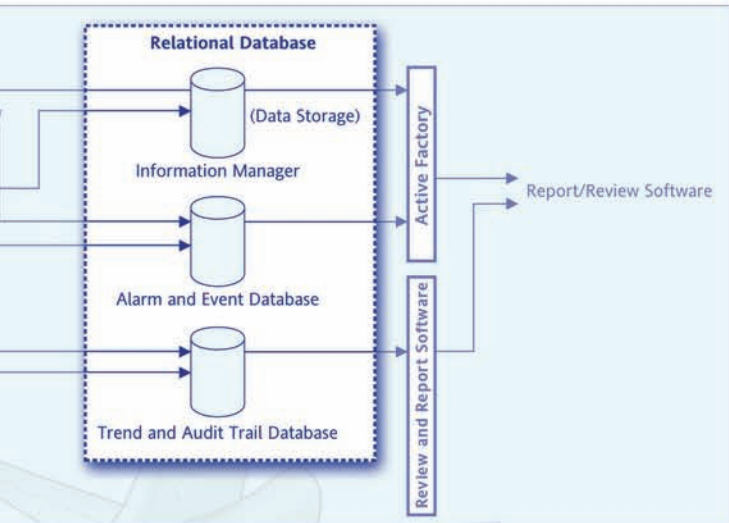

## Support for historical reporting and review of data

- Review software facility to replay secure data files
- Ability to generate accurate and complete copies of records in human readable format and in industry standard electronic packages.
- Report flexible software facility to provide custom records and reports
- Sort records on parameter data or batch data

## Support for Temperature Uniformity Surveys (TUS) and System Accuracy Tests (SATs)

Eurotherm Digital Data Management products are ideal for TUS and SATs with application specific configuration and reporting designed for the accredited heat treatment workshop including:

- Products meet the demands of Field Test Instruments as defined in AMS2750D
- Automatic routines are available for the automation of Temperature Uniformity Surveys
- Tamperproof records can be appended with user notes and operator information
- TUS and SATs data can be exported to Eurotherm Report for the automated production of accredited reports.

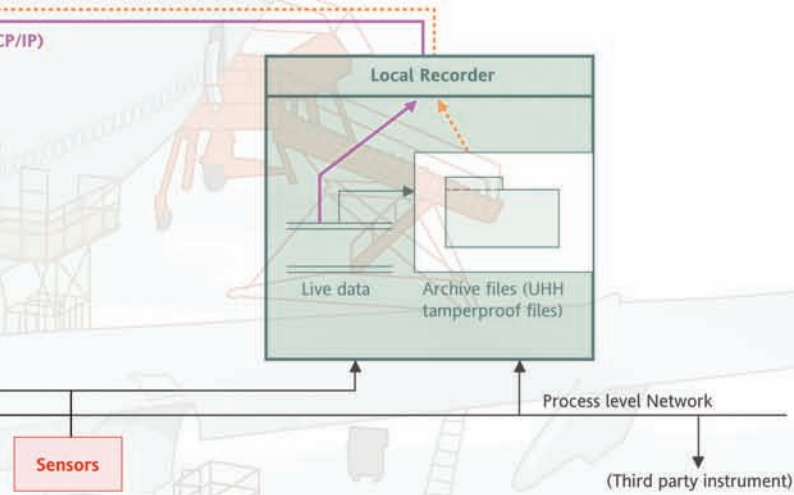

## Support for Maintenance and Efficient Energy Usage

Gas Carburing Data logging systems from Eurotherm can be configured to aid the efficient use of plant and equipment and advise of maintenance events and audit requirements.

- Energy Usage and furnace energy profiling
- Plant uptime and equipment running time
- Maintenance events frequency
- Calibration and audit frequency alarms

**Furnace Thermal Survey Report**

Certificate Number: TSR123  
Customer: AA Treatments  
Furnace Identifier or Tag: ABC123

Thermocouple Accuracy as Indicated	T9.7C	U99.7C
T9C.1	0.02 °C	0.1 °C
T9C.2	0.02 °C	0.1 °C
T9C.3	0.02 °C	0.1 °C
T9C.4	0.02 °C	0.1 °C
T9C.5	0.02 °C	0.1 °C
T9C.6	0.02 °C	0.1 °C
T9C.7	0.02 °C	0.1 °C
T9C.8	0.02 °C	0.1 °C
T9C.9	0.02 °C	0.1 °C
T9C.10	0.02 °C	0.1 °C
T9C.11	0.02 °C	0.1 °C
T9C.12	0.02 °C	0.1 °C
T9C.13	0.02 °C	0.1 °C
T9C.14	0.02 °C	0.1 °C
T9C.15	0.02 °C	0.1 °C
T9C.16	0.02 °C	0.1 °C
T9C.17	0.02 °C	0.1 °C
T9C.18	0.02 °C	0.1 °C
T9C.19	0.02 °C	0.1 °C
T9C.20	0.02 °C	0.1 °C

**Survey Report**

Certificate Number: TSR123  
Customer: AA Treatments  
Furnace Identifier or Tag: ABC123

**Survey Equipment**

Thermocouple	Channel Number
T9C.1	119870
T9C.2	119870
T9C.3	119870
T9C.4	119870
T9C.5	119870
T9C.6	119870
T9C.7	119870
T9C.8	119870
T9C.9	119870
T9C.10	119870
T9C.11	119870
T9C.12	119870
T9C.13	119870
T9C.14	119870
T9C.15	119870
T9C.16	119870
T9C.17	119870
T9C.18	119870
T9C.19	119870
T9C.20	119870

**Furnace Thermal Survey Report**

Certificate Number: TSR123  
Recorded Data: Owen GA, 150 seconds  
Recorded at an interval of: 150 seconds  
Customer: AA Treatments  
Address: Goodwood Road, Goodwood Industrial Estate, Eastlyon

Furnace Identifier or Tag: ABC123  
Furnace Manufacturer: HT Furnaces Ltd  
Model No.: 12364  
Serial Number: 123643Y2  
Eurotherm Test Procedure: Report Procedure DP006-4  
Survey Date: 11 April 2006  
Next Survey Due: 11 July 2006

Survey Engineer: Steve Wooley  
User: A.N. Other

Eurotherm Ltd  
Furnace Data Sampling, Working, Heat Soaks, 8010 9PL Ltd  
General Enquiries Tel: +44(0)1293 288000 Fax: +44(0)1293 288000  
Sales Enquiries Tel: +44(0)1293 288000 Fax: +44(0)1293 288000  
info@eurotherm.co.uk www.eurotherm.co.uk

Eurotherm Ltd  
No. 44 220101 288000  
info@eurotherm.co.uk

Page 1 of 10 Thermal Survey Reporting Software Version 1.0000

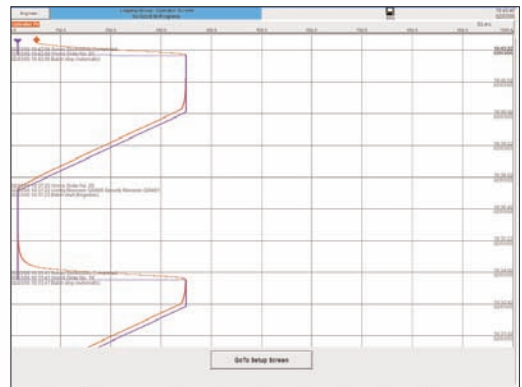

# Discrete Control Solution

## Typical Dual Chamber discrete Batch Sealed Quench Furnace

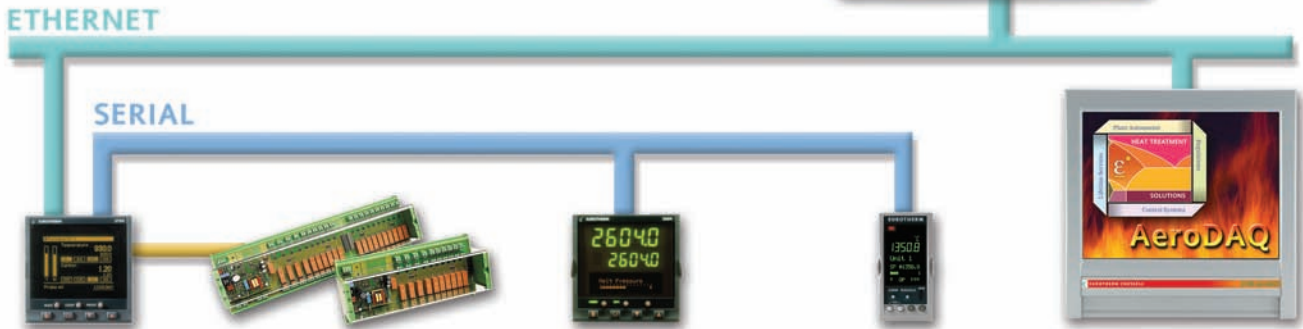

### TEMPERATURE AND ATMOSPHERE CONTROL

- Furnace T/C
- Probe T/C
- Probe mv
- Air/Gas additions
- Probe clean
- Safety gas
- Protection gas
- End of prog
- Carbonitride gas
- Select quench cycle
- Carbon loop in standby

### PLANT I/O ACQUISITION

- Furnace start
- Transfer to quench
- N2 gas available
- Quench empty
- Furnace door I/O
- Load in furnace
- Load in quench tank
- Enable heating

### QUENCH TANK CONTROL

- Quench T/C
- Oil flow up
- Oil flow down
- Oil not over temp
- Atmosphere quench
- Load next quench cycle
- End of quench
- Start quench
- Heat/cool O/P
- Oil flow fast
- Oil quench

### TRACKING OVER TEMPERATURE

- Over temperature
- Tracking alarm
- Full scale alarm

### DATA MANAGEMENT SOLUTION

- Work T/Cs
- Programme select
- Energy monitoring
- Alarms
- Tamperproof data storage

#### 2704 AND I/O EXPANDER

Used for Temperature programming and control , Carbon Potential Programming and Control Furnace I/O access and Control

#### 2604

Used for Quench Oil Control and Quench Sequence Control

#### 3504

Used for furnace absolute high temperature alarm and deviation high process temperature alarm

#### 6180A

Used for Data Management and Operator HMI

Quench Times	Minutes	Elapsed
Air Quench Time	30	0.0
Oil Quench Time	30	0.0
Fast Oil Time	30	0.0
Oil Drip Time	30	0.0

**BATCH ENTRY**

- LOAD 1 AAA1234AA
- LOAD 2 BBB1234BB
- LOAD 3 CCC1234CC
- LOAD 4 DDD1234DD
- LOAD 5 EEE1234EE
- LOAD 6 FFF1234FF

**BASIC OPERATOR INSTRUCTIONS:**

- 1: ENTER BATCH INFORMATION BY PRESSING INSIDE TEXT AREAS
- 2: PRESS THE "LOAD PROGRAM PAGE" BUTTON TO SELECT A PROGRAM TO RUN
- 3: ONCE PROGRAM IS SELECTED, "LOAD IT" AND THEN "DOWNLOAD" IT USING THE POP-UP MENU
- 4: THE BATCH RECORDING WILL NOW START AS INDICATED IN TOP LEFT BOX
- 5: PRESS MAIN MENU BUTTON THEN SELECT "PROGRAM" WHERE THE PROGRAM CAN BE RUN

TREATMENT



# Integrated Control and Visualisation Solution

## Batch Quench Furnace

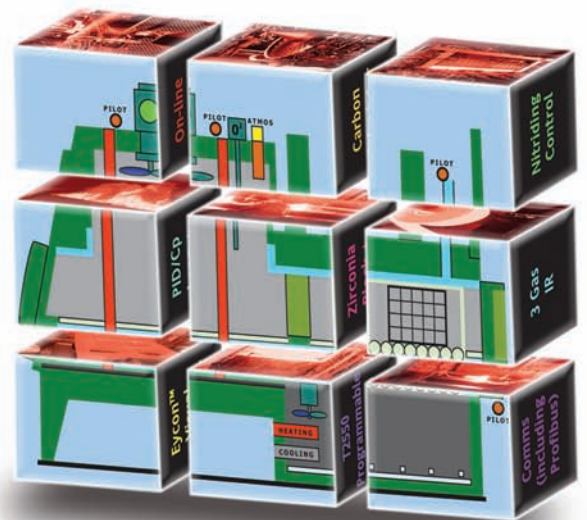
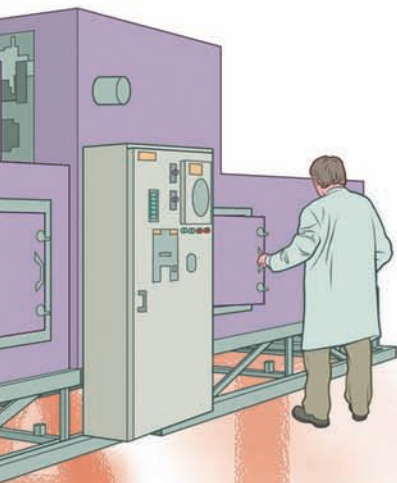
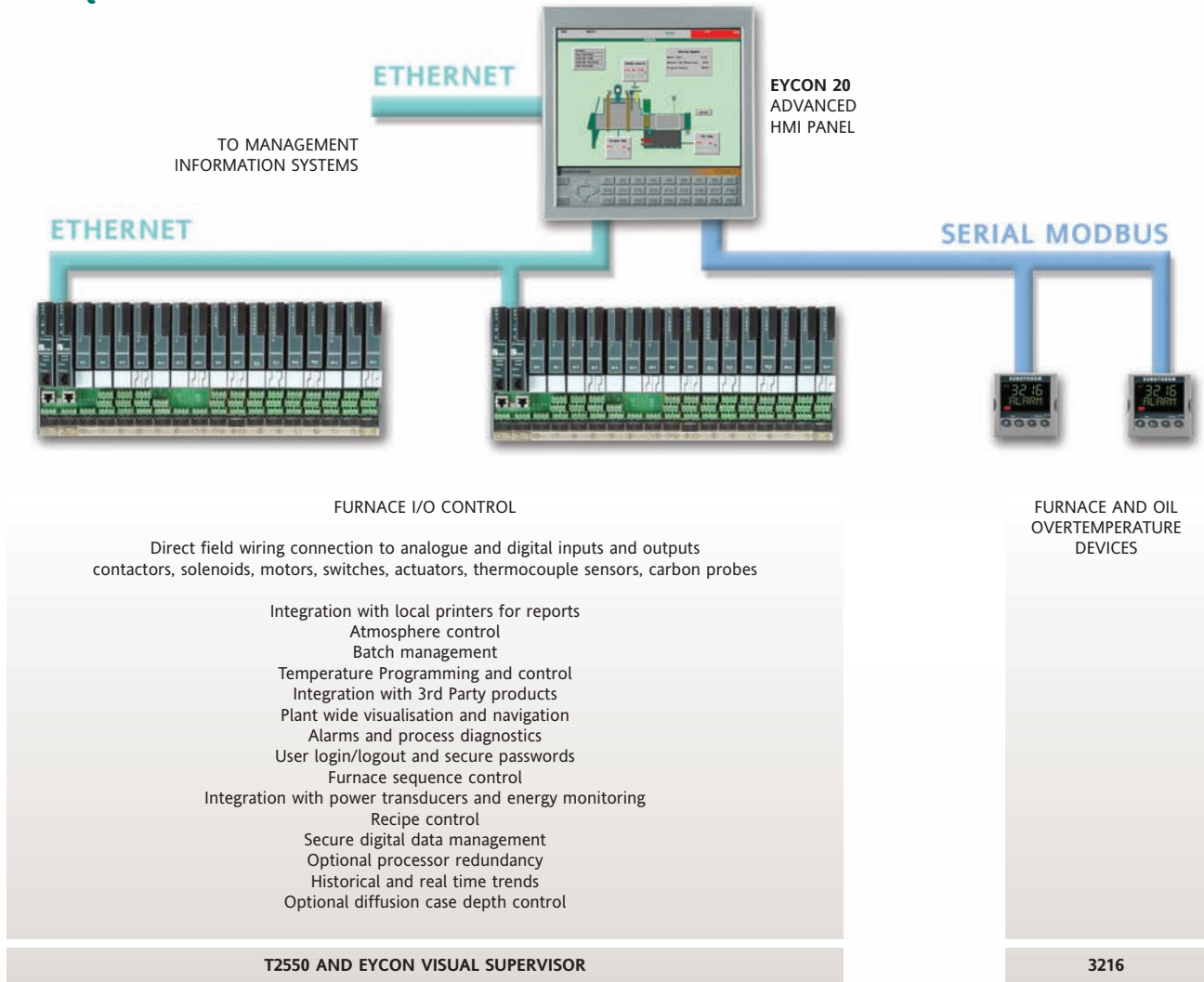

**SIMPLE**  
**SCALABLE**  
**ACCURATE**

# Eurotherm: International sales and service

Understanding and providing local support is a key part of Eurotherm business. Complementing worldwide Eurotherm offices are a whole range of partners and a comprehensive technical support team, to ensure you get a service you will want to go back to.

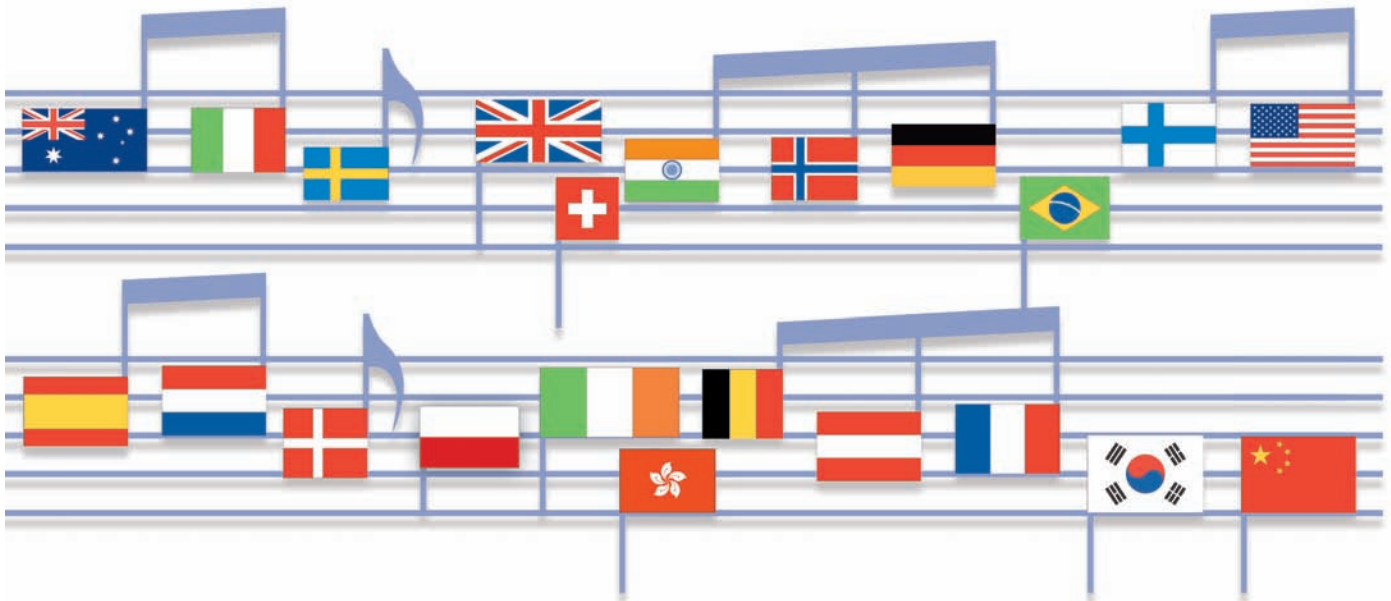

**AUSTRALIA** Sydney  
Eurotherm Pty. Ltd.  
T (+61 2) 9838 0099  
F (+61 2) 9838 9288  
E [info.au@eurotherm.com](mailto:info.au@eurotherm.com)

**AUSTRIA** Vienna  
Eurotherm GmbH  
T (+43 1) 7987601  
F (+43 1) 7987605  
E [info.at@eurotherm.com](mailto:info.at@eurotherm.com)

**BELGIUM & LUXEMBOURG** Moha  
Eurotherm S.A./N.V.  
T (+32) 85 274080  
F (+32) 85 274081  
E [info.be@eurotherm.com](mailto:info.be@eurotherm.com)

**BRAZIL** Campinas-SP  
Eurotherm Ltda.  
T (+5519) 3707 5333  
F (+5519) 3707 5345  
E [info.br@eurotherm.com](mailto:info.br@eurotherm.com)

**DENMARK** Copenhagen  
Eurotherm Danmark AS  
T (+45 70) 234670  
F (+45 70) 234660  
E [info.dk@eurotherm.com](mailto:info.dk@eurotherm.com)

**FINLAND** Abo  
Eurotherm Finland  
T (+358) 22506030  
F (+358) 22503201  
E [info.fi@eurotherm.com](mailto:info.fi@eurotherm.com)

**FRANCE** Lyon  
Eurotherm Automation SA  
T (+33 478) 664500  
F (+33 478) 352490  
E [info.fr@eurotherm.com](mailto:info.fr@eurotherm.com)

**GERMANY** Limburg  
Eurotherm Deutschland GmbH  
T (+49 6431) 2980  
F (+49 6431) 298119  
E [info.de@eurotherm.com](mailto:info.de@eurotherm.com)

**HONG KONG & CHINA**  
Eurotherm Limited North Point  
T (+85 2) 28733826  
F (+85 2) 28700148  
E [info.hk@eurotherm.com](mailto:info.hk@eurotherm.com)

**Guangzhou Office**  
T (+86 20) 8755 5099  
F (+86 20) 8755 5831  
E [info.cn@eurotherm.com](mailto:info.cn@eurotherm.com)

**Beijing Office**  
T (+86 10) 6567 8506  
F (+86 10) 6567 8509  
E [info.cn@eurotherm.com](mailto:info.cn@eurotherm.com)

**Shanghai Office**  
T (+86 21) 6145 1188  
F (+86 21) 6145 1187  
E [info.cn@eurotherm.com](mailto:info.cn@eurotherm.com)

**INDIA** Chennai  
Eurotherm India Limited  
T (+91 44) 24961129  
F (+91 44) 24961831  
E [info.in@eurotherm.com](mailto:info.in@eurotherm.com)

**IRELAND** Dublin  
Eurotherm Ireland Limited  
T (+353 1) 4691800  
F (+353 1) 4691300  
E [info.ie@eurotherm.com](mailto:info.ie@eurotherm.com)

**ITALY** Como  
Eurotherm S.r.l.  
T (+39 031) 975111  
F (+39 031) 977512  
E [info.it@eurotherm.com](mailto:info.it@eurotherm.com)

**KOREA** Seoul  
Eurotherm Korea Limited  
T (+82 31) 2738507  
F (+82 31) 2738508  
E [info.kr@eurotherm.com](mailto:info.kr@eurotherm.com)

**NETHERLANDS** Alphen a/d Rijn  
Eurotherm B.V.  
T (+31 172) 411752  
F (+31 172) 417260  
E [info.nl@eurotherm.com](mailto:info.nl@eurotherm.com)

**NORWAY** Oslo  
Eurotherm A/S  
T (+47 67) 592170  
F (+47 67) 118301  
E [info.no@eurotherm.com](mailto:info.no@eurotherm.com)

**POLAND** Katowice  
Invensys Eurotherm Sp z o.o.  
T (+48 32) 2185100  
F (+48 32) 2177171  
E [info.pl@eurotherm.com](mailto:info.pl@eurotherm.com)

**SPAIN** Madrid  
Eurotherm España SA  
T (+34 91) 6616001  
F (+34 91) 6619093  
E [info.es@eurotherm.com](mailto:info.es@eurotherm.com)

**SWEDEN** Malmo  
Eurotherm AB  
T (+46 40) 384500  
F (+46 40) 384545  
E [info.se@eurotherm.com](mailto:info.se@eurotherm.com)

**SWITZERLAND** Wollerau  
Eurotherm Produkte (Schweiz) AG  
T (+41 44) 7871040  
F (+41 44) 7871044  
E [info.ch@eurotherm.com](mailto:info.ch@eurotherm.com)

**UNITED KINGDOM** Worthing  
Eurotherm Limited  
T (+44 1903) 268500  
F (+44 1903) 265982  
E [info.uk@eurotherm.com](mailto:info.uk@eurotherm.com)  
[www.eurotherm.co.uk](http://www.eurotherm.co.uk)

**U.S.A.** Leesburg VA  
Eurotherm Inc.  
T (+1 703) 443 0000  
F (+1 703) 669 1300  
E [info.us@eurotherm.com](mailto:info.us@eurotherm.com)  
[www.eurotherm.com](http://www.eurotherm.com)

Eurotherm is also represented in the following countries:

- |                               |                              |
|-------------------------------|------------------------------|
| <i>Algeria</i>                | <i>Malaysia</i>              |
| <i>Azerbaijan</i>             | <i>Mali</i>                  |
| <i>Bahrain</i>                | <i>Mexico</i>                |
| <i>Bangladesh</i>             | <i>New Zealand</i>           |
| <i>Benin</i>                  | <i>Niger</i>                 |
| <i>Bosnia and Herzegovina</i> | <i>Nigeria</i>               |
| <i>Bulgaria</i>               | <i>Oman</i>                  |
| <i>Burkina Faso</i>           | <i>Pakistan</i>              |
| <i>Cameroon</i>               | <i>Philippines</i>           |
| <i>Canada</i>                 | <i>Puerto Rico</i>           |
| <i>Czech Republic</i>         | <i>Qatar</i>                 |
| <i>Egypt</i>                  | <i>Romania</i>               |
| <i>Georgia</i>                | <i>Russia</i>                |
| <i>Greece</i>                 | <i>Saudi Arabia</i>          |
| <i>Guinea-Conakry</i>         | <i>Serbia and Montenegro</i> |
| <i>Hungary</i>                | <i>Singapore</i>             |
| <i>Indonesia</i>              | <i>Slovak Republic</i>       |
| <i>Iran</i>                   | <i>Slovenia</i>              |
| <i>Iraq</i>                   | <i>South Africa</i>          |
| <i>Israel</i>                 | <i>Sri Lanka</i>             |
| <i>Ivory Coast</i>            | <i>Thailand</i>              |
| <i>Japan</i>                  | <i>Togo</i>                  |
| <i>Jordan</i>                 | <i>Tunisia</i>               |
| <i>Kazakhstan</i>             | <i>Turkey</i>                |
| <i>Kenya</i>                  | <i>Turkmenistan</i>          |
| <i>Kuwait</i>                 | <i>UAE</i>                   |
| <i>Latvia</i>                 | <i>Ukraine</i>               |
| <i>Lithuania</i>              | <i>Uzbekistan</i>            |

ED55

Represented by:

© Copyright Eurotherm Limited 2007

Invensys, Eurotherm, the Eurotherm logo, Chessell, EurothermSuite, Mini8, Eyon, Eyris, EPower and Wonderware are trademarks of Invensys plc, its subsidiaries and affiliates. All other brands may be trademarks of their respective owners.

All rights are strictly reserved. No part of this document may be reproduced, modified, or transmitted in any form by any means, nor may it be stored in a retrieval system other than for the purpose to act as an aid in operating the equipment to which the document relates, without the prior written permission of Eurotherm limited.

Eurotherm Limited pursues a policy of continuous development and product improvement. The specifications in this document may therefore be changed without notice. The information in this document is given in good faith, but is intended for guidance only.

Eurotherm Limited will accept no responsibility for any losses arising from errors in this document.

Part No. HA029303 Issue 2



Printed on  
recycled paper  
in England 11.07