

PG10

PenGUIn™ machine-HMI

MODEL

- Configured using GUIcon software
- Up to 5 RS232/422/485 communication ports (2 RS232 and 1 RS422/485 on-board, 1 RS232 and 1 RS422/485 on optional communications card)
- 10 Base T/100 Base Ethernet port to network units and host web pages (2nd Ethernet port optional)
- USB port to download the unit's configuration from a PC or for data transfers to a PC
- Unit's configuration is stored in non-volatile memory (32 MB flash)
- CompactFlash® socket to increase memory capacity
- 10.4 inch TFT 32K VGA 640 x 480 pixel LCD or SVGA 800 x 600 LCD
- Outdoor unit with UV rated overlay menus
- 8-button keypad for on-screen menus
- Three front panelled indicators
- Power unit from 24V dc \pm 20% supply
- Resistive analog touchscreen

invenSys

Eurotherm

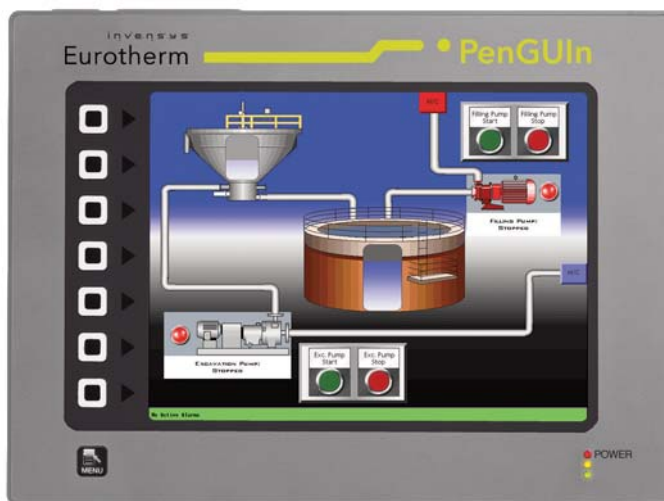

10.4" Color Touchscreen Specification Sheet

General Description

The PG10 Operator Interface Terminal combines unique capabilities normally only expected from high-end units but at a very affordable price. It is built around a high performance core with integrated functionality. This core allows the PG10 to perform many of the normal features of the Paradigm range of Operator Interfaces while improving and adding new features.

The PG10 is able to communicate with many different types of hardware using high-speed RS232/422/485 communications ports and Ethernet 10 Base T/100 Base-TX communications. In addition, the PG10 features a USB port for fast downloads of configuration files and access to trending and data logging. A CompactFlash socket is provided so that Flash cards can be used to collect your trending and data logging information as well as to store larger configuration files.

In addition to accessing and controlling external resources, the PG10 allows a user to easily view and enter information. Users can enter data through the touchscreen or front panel 8-button keypad.

Contents of Package

- PG10 Operator Interface.
- Panel Gasket.
- This hardware bulletin.
- Template for panel cutout.
- Hardware fittings for mounting unit into panel.
- Terminal block for connecting power.

For use in hazardous locations:
Class 1, Divisions 2,
Groups A, B, C and D

UL US LISTED
43NH
PROCESS CONTROL EQUIPMENT

CE

imagine communication without limitation

Specification

Power Requirements

Must use NEC Class 2 or Limited Power Source (LPS) rated power supply.
Power connection via removable three position terminal block.

Supply Voltage: +24V dc $\pm 20\%$ @ 30W

Note: The PG10's circuit common is not connected to the enclosure of the unit.
See "Connecting to Earth Ground" in the section "Installing and Powering the PG10."

Battery

Lithium coin cell CR2025: Typical lifetime of 10 years

Display

Size: 10.4 inch
Type: TFT
Colors: 32K
Pixels: 640 x 480
Brightness: 450 cd/m²
Backlight type: CCFL
Backlight life*: 50,000 HR TYP

*Lifetime at room temperature. Refer to "Display" in "Software/Unit Operation"

Keypad

8 key: For on-screen menus

Screen

Touchscreen: Resistive analog

Memory

On board user memory: 32 Mbyte of non-volatile Flash memory
Memory Card: CompactFlash Type II slot for Type I and Type II CompactFlash cards

Communications

USB Port: Adheres to USB 2.0 specification full speed only via Type B connection

WARNING - DO NOT CONNECT OR DISCONNECT CABLES WHILE POWER IS APPLIED UNLESS AREA IS KNOWN TO BE NON-HAZARDOUS. USB PORT IS FOR SYSTEM SET-UP AND DIAGNOSTICS AND IS NOT INTENDED FOR PERMANENT CONNECTION.

USB Host Ports: Comply with Universal Serial Bus Specification Rev 2.0. Supports data transfers at full-speed. Hardware over-current protected (0.5 A max per port)

Serial Ports: Serial ports on the PG10 are individually isolated. Format and Baud Rates for each port are individually software programmable up to 115,200 baud

PGM Port: RS232 port via RJ12
COMMS Ports: RS422/485 port via RJ45, and RS232 port via RJ12

DH485 TXEN: Transmit enable; open collector, $V_{OH} = 15$ VDC, $V_{OL} = 0.5$ V @ 25 mA max

Note: For additional information on the communications or signal common and connections to earth ground please see the "Connecting to Earth Ground" in the section "Installing and Powering the PG10."

Ethernet Ports: 10 BASE-T / 100 BASE-TX
RJ45 jack is wired as an NIC (Network Interface Card). The jack shield is electrically connected to Earth ground
A secondary Ethernet port (with its own Mac ID) is available as an option

Environmental Conditions

Operating Temperature Range: 0 to 50°C
Storage Temperature Range: -20 to 70°C
Operating & Storage Humidity: 80% maximum relative humidity (non-condensing) from 0 to 50°C
Operational 5 to 150Hz, in X, Y, Z direction for 1.5 hours, 2g
Shock to IEC 68-2-27: Operational 35g, 11 msec in 3 directions

Certifications and Compliances

Safety: For safety summary see page 6
UL Listed, File #E340808, UL61010-1, ANSI/ISA 12.12.01-2007, CAN/CSA 22.2 No. 61010.1, CSA 22.2 No. 213 and File #E340808, UL61010-1, CSA 22.2 No. 61010-1
LISTED by Und. Lab. Inc. to U.S. and Canadian safety standards
Type 4X Indoor Enclosure rating (Face only), UL50
IECEE CB Scheme Test Report #E340808-A1-CB-3
Issued by Underwriters Laboratories Inc.
IEC 61010-1, EN 61010-1: Safety requirements for electrical equipment for measurement, control, and laboratory use, Part 1.
IP66 Enclosure rating (Face only), IEC 529

Electrical Compatibility

Emissions and Immunity to EN 61326: 2006: Electrical Equipment for Measurement, Control and Laboratory use.

Immunity to Industrial Locations

Electrical discharge:	EN 61000-4-2	Criterion A 4kV contact discharge 8kV air discharge
Electromagnetic RF fields:	EN 61000-4-3	Criterion A 10V/m (80 MHz to 1 GHz) 3V/m (1.4 GHz to 2 GHz) 1V/m (2 GHz to 2.7 GHz)
Fast transients (burst):	EN 61000-4-4	Criterion B 2kV power 1kV signal
Surge:	EN 61000-4-5	Criterion B 1kV L-L, 2kV L-G power 1kV signal
RF conducted interference:	EN 61000-4-6	Criterion A 3kV/rms
Power freq. magnetic field:	EN 61000-4-8	Criterion A 30A/m

Emissions

Emissions: EN 55011 Class A

Notes:

1. Criterion A: Normal operation within specified limits.
2. Criterion B: Temporary loss of performance from which the unit self-recovers.

Connections

Compression cage-clamp terminal block
Wire gage: 12-30 AWG copper wire
Torque: 5-7 inch-pounds (56-79 N-cm)

Construction

Steel rear metal enclosure with NEMA 4X/IP66 aluminum front plate for indoor use only when correctly fitted with the gasket provided. Installation Category II, Pollution Degree 2.

Mounting Requirements

Panel thickness: 0.25" (6.3 mm) max
For NEMA 4X/IP66 sealing, a steel panel with a minimum thickness of 0.125" (3.17 mm) is recommended.
Mounting Stud Torque: 17 inch-pounds (1.92 N-m) max

Physical

Weight: 4.20 lbs (1.91 Kg)

Dimensions in inches (mm)

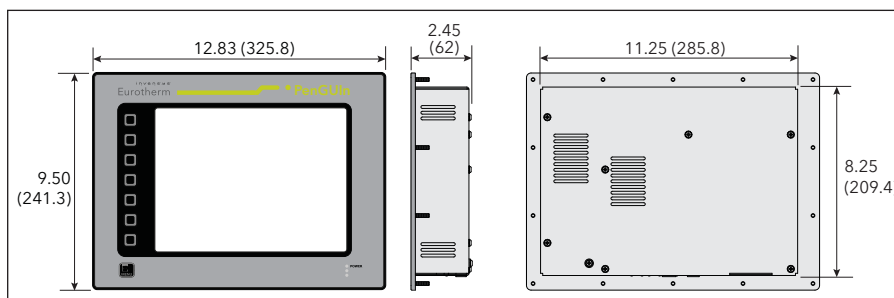

Installing and Powering the PG10

Mounting Instructions

This operator interface is designed for through-panel mounting. A panel cut-out diagram and a template are provided. Care should be taken to remove any loose material from the mounting cut-out to prevent such material falling into the operator interface during installation. A gasket is provided to enable sealing to NEMA 4X/IP66 specification. Install the 14 keps nuts provided and tighten evenly for uniform gasket compression.

Note: Tightening the keps nuts beyond a maximum of 17 inch-pounds (1.92 N-m) may cause damage to the front panel.

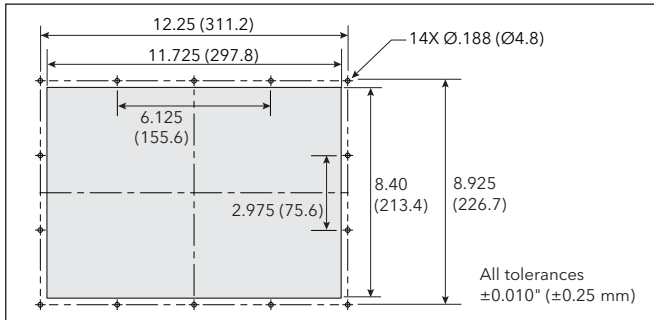

ALL NON-INCENDIVE CIRCUITS MUST BE WIRED USING DIVISION 2 WIRING METHODS AS SPECIFIED IN THE NATIONAL ELECTRICAL CODE NFPA 70, FOR INSTALLATION WITHIN THE UNITED STATES, OR AS SPECIFIED IN THE CANADIAN ELECTRICAL CODE FOR INSTALLATION IN CANADA.

Connecting to Earth Ground



The protective conductor terminal is bonded to conductive parts of the equipment for safety purposes and must be connected to an external protective earthing system.

Each PG10 has a chassis ground terminal on the back of the unit. Your unit should be connected to earth ground terminal (protective earth).

The chassis ground is not connected to the signal common of the unit. Maintaining isolation between earth ground and signal common is not required to operate your unit. Other equipment connected to this unit may require isolation between signal common and earth ground. To maintain isolation between signal common and earth ground, care must be taken when connections are made to the unit. For example; a power supply with isolation between its signal common and earth ground must be used. Also, plugging in a USB cable may connect the signal common and earth ground.¹

¹ USB's shield may be connected to earth ground at the host. USB's shield in turn may also be connected to the signal common.

Installing an Option Card



WARNING - EXPLOSION HAZARD - DO NOT DISCONNECT EQUIPMENT UNLESS POWER HAS BEEN DISCONNECTED AND THE AREA IS KNOWN TO BE NON-HAZARDOUS.

Each option card comes with a cable for communications and three screws for attaching the option card to the PG10's main board.

To install the option card, remove all power and I/O communications cables from the unit and remove the rear cover. Connect the cable from the option card to the connector on the main board. Be sure both ends of the cable are firmly seated into their appropriate connector housings. Use the three screws provided to mount the option card to the main board.

Carefully replace the rear cover by reversing the instructions for removing the rear cover.

Power Supply Requirement

The PG10 requires a 24V dc power supply rated at 30W. Your unit may draw less than the rated power depending upon the options being used. As additional features are used your unit will draw increasing amounts of power. Items that could cause increases in current are additional communications, optional communications card, CompactFlash card, and other features programmed through GUIcon.

In any case, it is very important that the power supply is mounted correctly if the unit is to operate reliably. Please take care to observe the following points:

- The power supply must be mounted close to the unit, with usually not more than 6 feet (1.8 m) of cable between the supply and the operator interface. Ideally, the shortest length possible should be used.
- The wire used to connect the operator interface's power supply should be at least 22-gage wire. If a longer cable run is used, a heavier gage wire should be used. The routing of the cable should be kept away from large contactors, inverters, and other devices which may generate significant electrical noise.
- A power supply with an NEC Class 2 or Limited Power Source (LPS) and SELV rating is to be used. This type of power supply provides isolation to accessible circuits from hazardous voltage levels generated by a mains power supply due to single faults. SELV is an acronym for "safety extra-low voltage." Safety extra-low voltage circuits shall exhibit voltages safe to touch both under normal operating conditions and after a single fault; such as a breakdown of a layer of basic insulation, or after the failure of a single component has occurred.



WARNING - EXPLOSION HAZARD - DO NOT DISCONNECT EQUIPMENT WHILE THE CIRCUIT IS LIVE OR UNLESS THE AREA IS KNOWN TO BE FREE OF IGNITABLE CONCENTRATIONS.

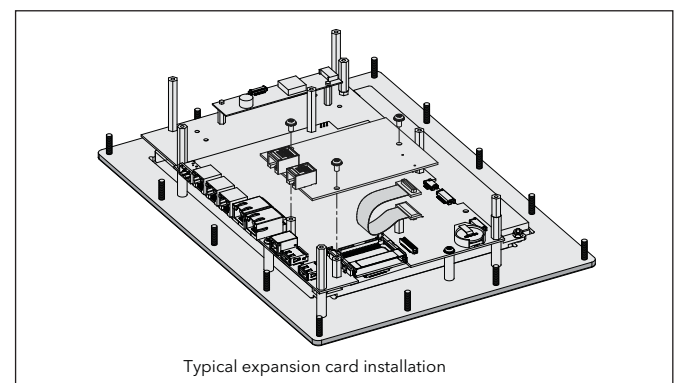
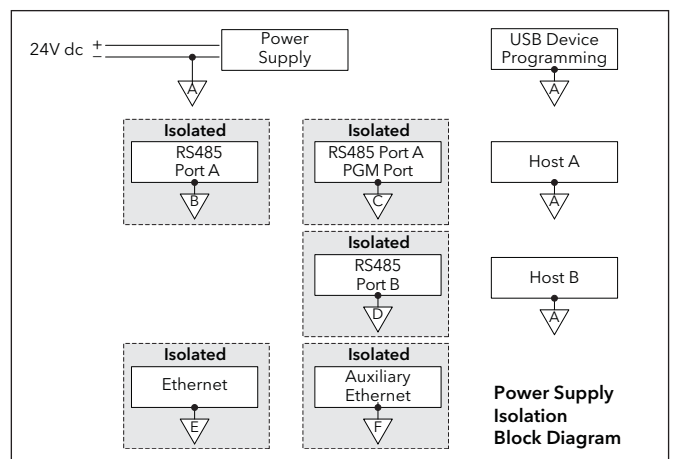

Communicating with the PG10

Configuring a PG10

The PG10 is configured using GULcon software. GULcon is available as a free download from the Eurotherm™ website. Updates to GULcon for new features and drivers are posted on the website as they become available. By configuring the PG10 using the latest version of GULcon, you are assured that your unit has the most up to date feature set. GULcon software can configure the PG10 through the RS232 PGM port, USB port, or CompactFlash.

The USB port is connected using a standard USB cable with a Type B connector. The driver needed to use the USB port will be installed with GULcon. If this driver has not been installed, it can be downloaded from the website.

The RS232 PGM port uses a programming cable made by Eurotherm to connect to the DB9 COM port of your computer. If you choose to make your own cable, use the "PG10 Port Pin Out Diagram" for wiring information.

The CompactFlash card can be used to program a PG10 by placing a configuration file and firmware on the CompactFlash card. The card is then inserted into the target PG10 and powered. Refer to the GULcon literature for more information on the proper names and locations of the files.

Accessing the CompactFlash Card via USB Device Port



WARNING - DO NOT CONNECT OR DISCONNECT CABLES WHILE POWER IS APPLIED UNLESS AREA IS KNOWN TO BE NON-HAZARDOUS. USB PORT IS FOR SYSTEM SET-UP AND DIAGNOSTICS AND IS NOT INTENDED FOR PERMANENT CONNECTION.

In order to transfer data from the CompactFlash card via the USB port, a driver must be installed on your computer. This driver is automatically installed with GULcon. Connect the PG10 to your PC with a USB cable, and follow "Mounting the CompactFlash" instructions in the GULcon 1.0 user manual.

Ethernet Communications

Ethernet communications can be established at either 10 BASE-T or 100 BASE-TX. The PG10 unit's RJ45 jack is wired as an NIC (Network Interface Card). For example, when wiring to a hub or switch use a straight-through cable, but when connecting to another NIC use a crossover cable.

The Ethernet connector contains two LEDs. A yellow LED in the upper right, and a bi-color green/amber LED in the upper left. The LEDs represent the following statuses:

LED Color	Description
Yellow solid	Link established
Yellow flashing	Data being transferred
Green	10 BASE-T Communications
Amber	100 BASE-TX Communications

The GULcon manual contains additional information on the Ethernet communications.

RS232 Port

The PG10 has two individually isolated RS232 ports. There is the PGM port and the COMMS port. Although only one of these ports can be used for programming, both ports can be used for communications with a PLC.

The RS232 PGM port can be used for either master or slave protocols with any PG10 configuration.

PG10 RS232 to a PC Serial Port			
PG10: RJ12	Name	PC: DB9	Name
4	COMM	1	DCD
5	Tx	2	Rx
2	Rx	3	Tx
	N/C	4	DTR
3	COM	5	GND
	N/C	6	DSR
1	CTS	7	RTS
6	RTS	8	CTS
	N/C	9	RI

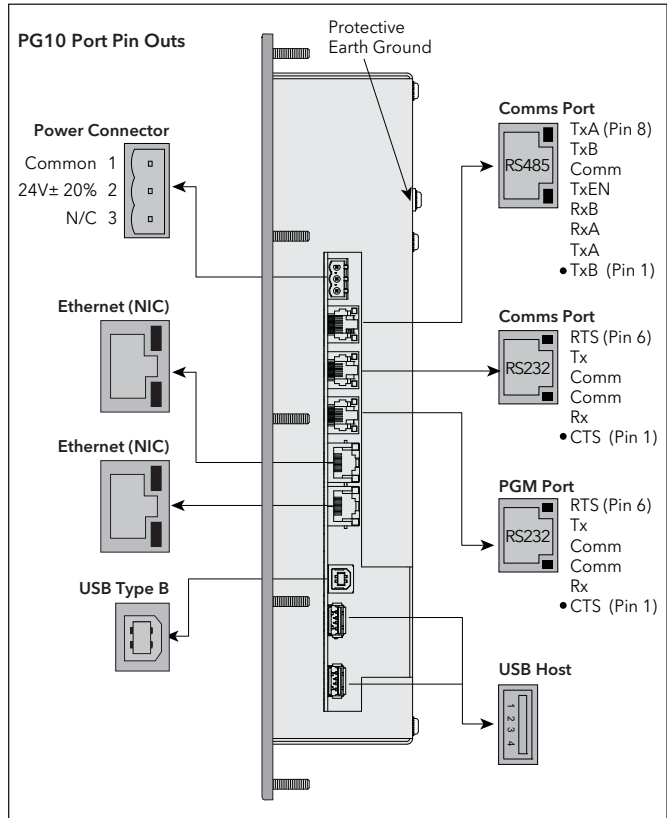

RS422/485 Comms Port

The PG10 has one RS422/485 port. This port can be configured to act as either RS422 or RS485.

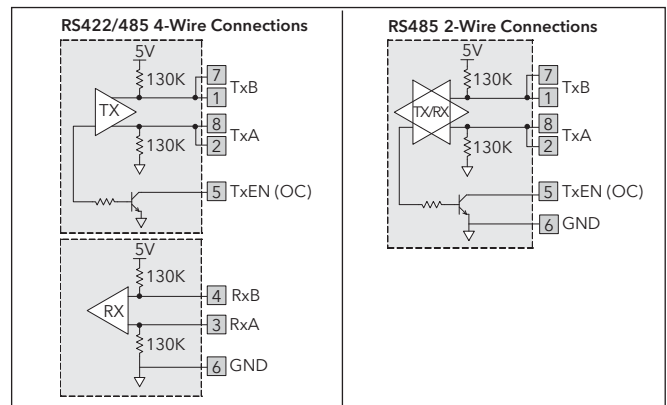

DH485 Communications

The PG6's RS422/485 COMMS port can also be used for Allen Bradley DH485 communications.

WARNING: The standard DH485 is not compatible with Allen Bradley equipment. A cable is available from Eurotherm.

PG10 to AB SLC 500 (CBLAB003) Connections			
RJ45: PG10	Name	RJ45: A-B	Name
1	TxB	1	A
2	TxA	2	B
3, 8	RxA	-	24V
4, 7	RxB	-	COMM
5	TxEN	5	TxEN
6	COMM	4	SHIELD
4, 7	TxB	-	COMM
3, 8	TxA	-	24V

Software/Unit Operation

GULcon Software

GULcon software is available as a free download from the Eurotherm website. The latest version of the software is always available from the website, and updating your copy is free.

Display

This operator interface uses a liquid crystal display (LCD) for displaying text and graphics. The PG10 display utilizes a cold cathode fluorescent tube (CCFL) for lighting the display.

Display backlights have a limited lifetime. Backlight lifetime is based upon the amount of time the display is turned on at full intensity. Turning the backlight off when the display is not in use can extend the lifetime of your backlight. This can be accomplished through the GULcon software when configuring your unit.

Backlight Replacement

CCFL Backlight



The PG10 backlight is not field replaceable for hazardous location applications. The unit must be returned to Eurotherm for repair.

The backlight assembly for the PG10 is field replaceable in non-hazardous locations only. Refer to the instructions included in the appropriate backlight replacement kit.

Front Panel LEDs

There are three front panel LEDs. Shown below is the default status of the LEDs.

LED	Indicator
Red (Top, labelled "PWR")	
Flashing	Unit is in the boot loader, no valid configuration is loaded. ¹
Steady	Unit is powered and running an application.
Yellow (Middle)	
Off	No CompactFlash card is present.
Steady	Valid CompactFlash card present.
Flashing rapidly	CompactFlash card being checked.
Flickering	Unit is writing to the CompactFlash, either because it is storing data, or because the PC connected via the USB port has locked the drive. ²
Flashing slowly	Incorrectly formatted CompactFlash card present.
Green (Bottom)	
Flashing	A tag is in an alarm state.
Steady	Valid configuration is loaded and there are no alarms present.

1. The operator interface is shipped without a configuration. After downloading a configuration, if the light remains in the flashing state continuously, try cycling power. If the LED still continues to flash, try downloading a configuration again.
2. Do not turn off power to the unit while this light is flickering. The unit writes data in two minute intervals. Later Microsoft operating systems will not lock the drive unless they need to write data; Windows 98 may lock the drive any time it is mounted, thereby interfering with logging. Refer to "Mounting the CompactFlash" in the GULcon User Manual.

Touchscreen

This operator interface utilizes a resistive analog touchscreen for user input. The unit will only produce an audible tone (beep) when a touch on an active touchscreen cell is sensed. The touchscreen is fully functional as soon as the operator interface is initialized, and can be operated with gloved hands.

Keypad

The PG10 keypad consists of eight keys for on-screen menus.

Troubleshooting your PG10

If for any reason you have trouble operating, connecting, or simply have questions concerning your new PG10, contact Eurotherm technical support. For contact information, refer to the back page of this Specification Sheet.

Battery and Time Keeping



WARNING - EXPLOSION HAZARD - THE AREA MUST BE KNOWN TO BE NON-HAZARDOUS BEFORE SERVICING/ REPLACING THE UNIT AND BEFORE INSTALLING OR REMOVING I/O WIRING AND BATTERY.



WARNING - EXPLOSION HAZARD - DO NOT DISCONNECT EQUIPMENT UNLESS POWER HAS BEEN DISCONNECTED AND THE AREA IS KNOWN TO BE NON-HAZARDOUS.

A battery is used to keep time when the unit is without power. Typical accuracy of the PG10 time keeping is less than one minute per month drift. The battery of a PG10 unit does not affect the unit's memory, all configurations and data is stored in non-volatile memory.



CAUTION: Risk of Electrical Shock The inverter board, attached to the mounting plate, supplies the high voltage to operate the backlight. Touching the inverter board may result in injury to personnel.



CAUTION: The circuit board contains static sensitive components. Before handling the operator interface without the rear cover attached; discharge static charges from your body by touching a grounded bare metal object. Ideally, handle the operator interface at a static controlled clean workstation. Also, do not touch the surface areas of the circuit board. Dirt, oil, or other contaminants may adversely affect circuit operation.

To change the battery of a PG10, remove power cabling and then the rear cover of the unit. To remove the cover, remove the five screws designated by the arrows on the rear of the unit. Then, by lifting the top side, hinge the cover, thus providing clearance for the connectors on the bottom side of the PCB as shown in the illustration below. Install in the reverse manner.

Remove the old battery* from the holder and replace with the new battery. Replace the rear cover, cables, and re-apply power. Using GULcon or the unit's keypad, enter the correct time and date.

* Please note that the old battery must be disposed of in a manner that complies with your local waste regulations. Also, the battery must not be disposed of in fire, or in a manner whereby it may be damaged and its contents come into contact with human skin.

The battery used by the PG10 is a lithium type CR2025.



WARNING- EXPLOSION HAZARD - BATTERIES MUST ONLY BE CHANGED IN AN AREA KNOWN TO BE NON-HAZARDOUS.

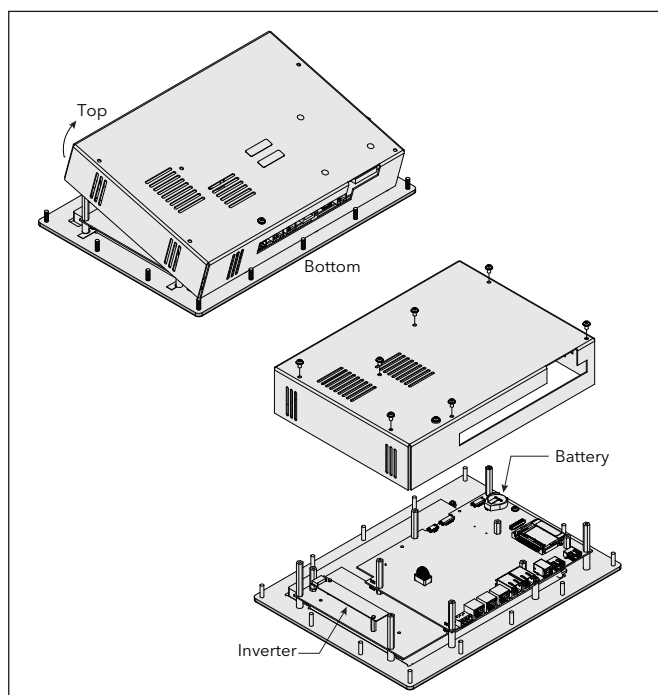

Optional Features and Accessories

CompactFlash Socket

CompactFlash socket is a Type II socket that can accept either Type I or II cards. Use cards with a minimum of 4 Mbytes and a maximum of 2 Gbytes with the PG10's CompactFlash socket. Cards are available at most computer and office supply retailers.

CompactFlash can be used for configuration transfers, larger configurations, data logging, and trending.

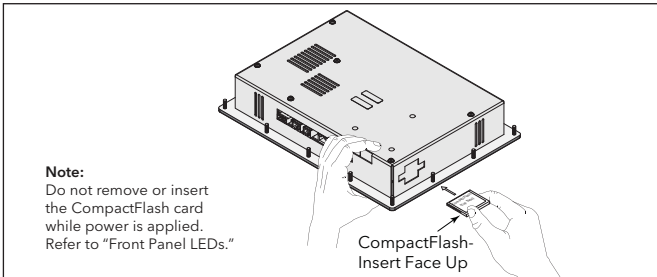

Information stored on a CompactFlash card by a PG10 can be read by a card reader attached to a PC. This information is stored in IBM (Windows®) PC compatible FAT16 file format.

Ordering Information

Model No	Description	Part Number
PG10	10.4" TFT Display Operator Interface (indoor), USB Host, Isolated Comms	PG10-S3E1VA
	10.4" TFT Display Operator Interface (indoor), Dual Ethernet, USB Host, Isolated Comms	PG10-S3E2VA
PGX-N	1 GB CompactFlash Card ¹	PGX-N01
	2 GB CompactFlash Card ¹	PGX-N02
PGX	RS 232/485 Optional Communication Card	PGX-RS
	CANopen Optional Communication Card	PGX-CAN
	DeviceNet Optional Communication Card	PGX-DNET
	Profibus DP Optional Communication Card	PGX-PBUS
	GSM/GPRS Modem Option Card ²	PGX-GSM
	GULcon 1.0 ³	
CBL	RS-232 Programming Cable	CBL01500
	USB Cable	CBL01900
	Communications Cables ⁴	CBLxxxxx
	Replacement Battery ⁵	PGX-BNL20000
	Protective Films	PG10-FILM

Notes:

1. Industrial grade two million write cycles.
2. Antenna (QANT0000) is NOT included with the card. Must be purchased separately if needed.
3. Download for free from www.eurotherm.com
4. Contact your Eurotherm distributor or visit our website for complete selection.
5. Battery type is lithium coin type CR2025.

Optional Communications Card

Eurotherm offers optional communication cards for fieldbus communications. These communication cards will allow your PG10 to communicate with many of the popular fieldbus protocols.

Eurotherm is also offering a communications card for additional RS232 and RS422/485 communications. Visit the Eurotherm website for information and availability of these cards.

Note

For reliable operation of this and other Eurotherm products, one of the following brands of CompactFlash card must be used

- SimpleTech • SMART® Modular • SanDisk® • Silicon Systems •
- Not all of the above manufacturers offer CompactFlash cards recognized to UL standards, which may be required for your application.

Safety Summary

All safety related regulations, local codes and instructions that appear in the manual or on equipment must be observed to ensure personal safety and to prevent damage to either the instrument or equipment connected to it. If equipment is used in a manner not specified by the manufacturer, the protection provided by the equipment may be impaired.

Do not use the controller to directly command motors, valves, or other actuators not equipped with safeguards. To do so can be potentially harmful to persons or equipment in the event of a fault to the controller.



The protective conductor terminal is bonded to conductive parts of the equipment for safety purposes and must be connected to an external protective earthing system.



WARNING - EXPLOSION HAZARD - SUBSTITUTION OF COMPONENTS MAY IMPAIR SUITABILITY FOR CLASS 1, DIVISION 2



CAUTION: Risk Of Danger.
Read complete instructions prior to installation and operation of the unit.



CAUTION: Risk of electric shock.

Eurotherm: International sales and service

www.eurotherm.com

AUSTRALIA Melbourne
T (+61 0) 8562 9800
E info.eurotherm.au@invensys.com

AUSTRIA Vienna
T (+43 1) 7987601
E info.eurotherm.at@invensys.com

BELGIUM & LUXEMBOURG Moha
T (+32) 85 274080
E info.eurotherm.be@invensys.com

BRAZIL Campinas-SP
T (+5519) 3707 5333
E info.eurotherm.br@invensys.com

CHINA
T (+86 21) 61451188
E info.eurotherm.cn@invensys.com

Beijing Office
T (+86 10) 5909 5700
E info.eurotherm.cn@invensys.com

FRANCE Lyon
T (+33 478) 664500
E info.eurotherm.fr@invensys.com

GERMANY Limburg
T (+49 6431) 2980
E info.eurotherm.de@invensys.com

INDIA Mumbai
T (+91 22) 67579800
E info.eurotherm.in@invensys.com

IRELAND Dublin
T (+353 1) 4691800
E info.eurotherm.ie@invensys.com

ITALY Como
T (+39 031) 975111
E info.eurotherm.it@invensys.com

KOREA Seoul
T (+82 2) 2090 0900
E info.eurotherm.kr@invensys.com

NETHERLANDS Alphen a/d Rijn
T (+31 172) 411752
E info.eurotherm.nl@invensys.com

POLAND Katowice
T (+48 32) 78395000
E info.eurotherm.pl@invensys.com

SPAIN Madrid
T (+34 91) 6616001
E info.eurotherm.es@invensys.com

SWEDEN Malmo
T (+46 40) 384500
E info.eurotherm.se@invensys.com

SWITZERLAND Wollerau
T (+41 44) 7871040
E info.eurotherm.ch@invensys.com

UNITED KINGDOM Worthing
T (+44 1903) 268500
E info.eurotherm.uk@invensys.com

U.S.A. Ashburn VA
T (+1 703) 724 7300
E info.eurotherm.us@invensys.com

ED63

© Copyright Eurotherm Limited 2011

Invensys, Eurotherm, the Eurotherm logo, Chessell, EurothermSuite, Mini8, Eycon, Eyris, EPower nanodac and Wonderware are trademarks of Invensys plc, its subsidiaries and affiliates. CompactFlash is a registered trademark of CompactFlash Association. All other brands may be trademarks of their respective owners.

All rights are strictly reserved. No part of this document may be reproduced, modified, or transmitted in any form by any means, nor may it be stored in a retrieval system other than for the purpose to act as an aid in operating the equipment to which the document relates, without the prior written permission of Eurotherm Limited.

Eurotherm Limited pursues a policy of continuous development and product improvement. The specifications in this document may therefore be changed without notice. The information in this document is given in good faith, but is intended for guidance only.

Eurotherm Limited will accept no responsibility for any losses arising from errors in this document.

i n v e n s y s
Operations Management