

S9574

MODEL

ALIN Active Hubs Product Data

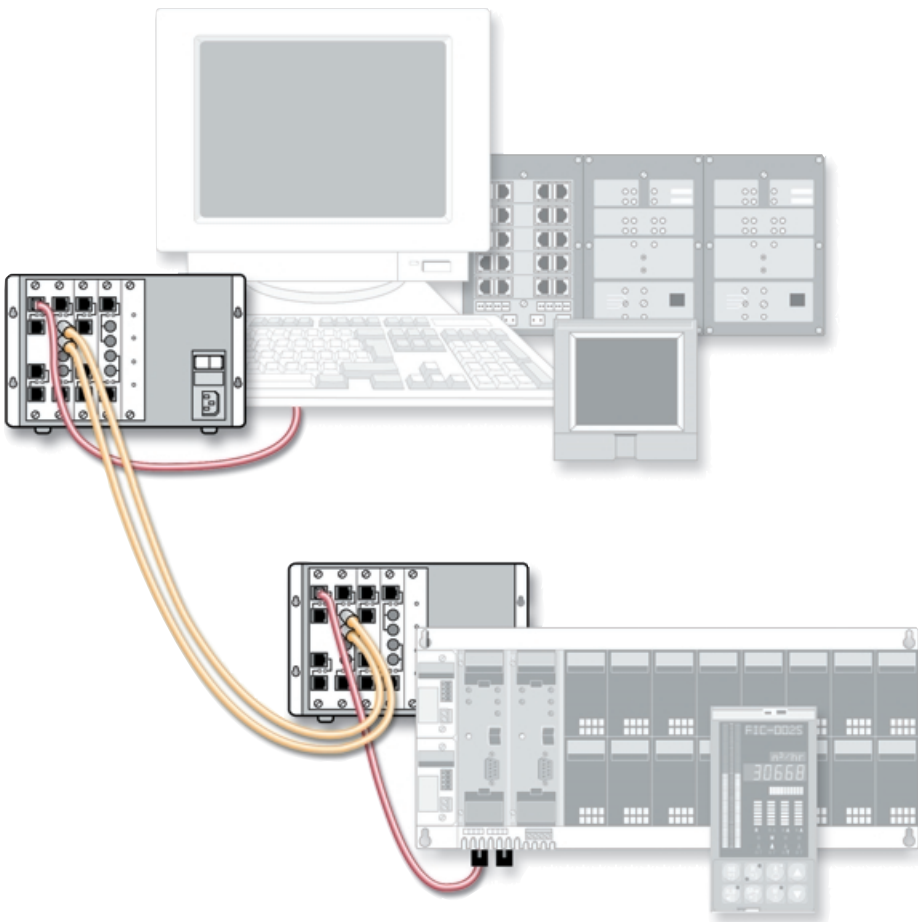

EUROTHERM

CONTROLS
DATA MANAGEMENT
PROCESS AUTOMATION

S9574 MODHUB (ALIN ACTIVE HUBS)

- Twisted-pair or fibre-optic cable
- Increase ALIN node capacity to 254 nodes
- Transmission distances up to 5000m
- Electrical isolation
- High noise immunity
- Redundant connection for dual server workstations

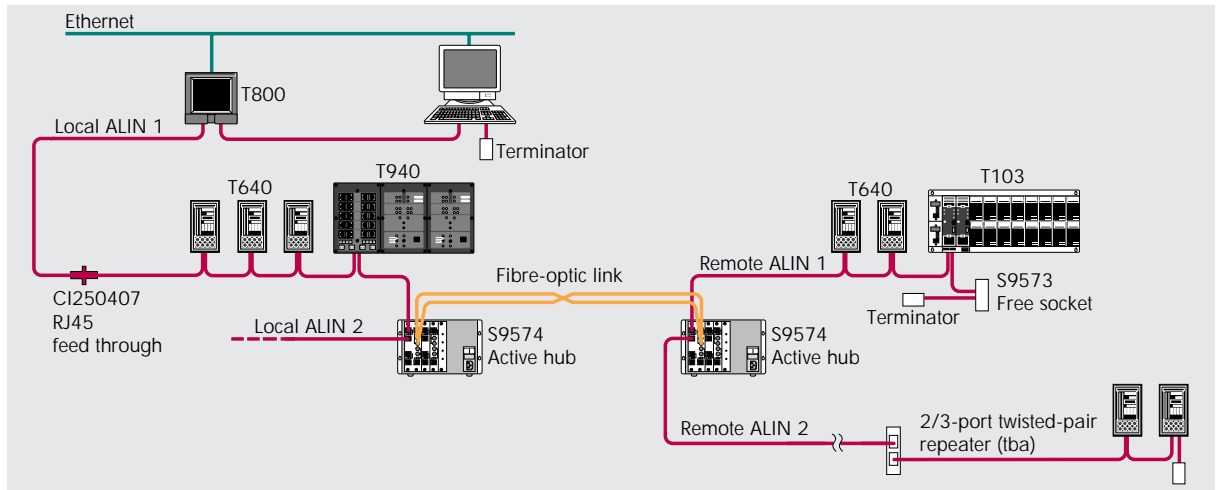

ALIN network connectivity

INTRODUCTION

The Eurotherm Process Automation distributed control system uses the ALIN (Arcnet Local Instrument Network) as a control network to link control units together. The network can be expanded by the use of active hubs which support both twisted-pair and fibre-optic technology. These modular active hubs (Mod-hubs) support multiple cable connections and allow many more nodes to be connected using a combination of bus and star topology.

Each cable connected to the Mod-hub can support up to eight nodes. The ALIN may be run over much longer distances by using a Mod-hub at either end of a fibre-optic link to convert the media from twisted-pair to glass or plastic fibre-optic cable. With the use of multiple fibre-optic hubs, the maximum distance over which a network may run is extended to five kilometres.

The use of this medium is also beneficial in applications requiring intrinsically safe equipment and in areas with a high degree of electrical noise and inter-building communication or areas with earth potential differences.

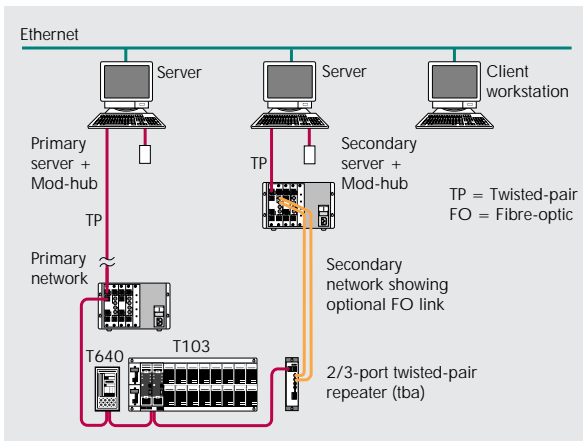

Redundant connection for dual server workstations

REDUNDANT CONNECTION FOR DUAL SERVER WORKSTATION

The integrity of an ALIN segment may be protected against the failure of a cable by the use of an active hub as a buffer/network isolator. Thus two server workstation connections may each be connected via an active hub. In the event of failure of the primary network, hubs or server workstation itself, the operator is assured access via the secondary server and its independent network connection.

NETWORK ARCHITECTURE

The Mod-hub may be considered a buffer/isolator supporting multiple network connections using either twisted-pair or fibre-optic cables. It allows mixed star/bus topologies both for expanding the node capacity of local network clusters, and for extending the network length over considerable distances.

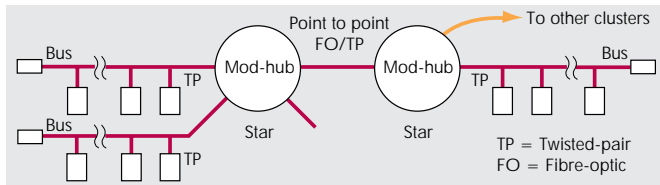

Distributed ALIN bus/star topology

INSTALLATION

ALIN twisted-pair cabling

Connection to the ALIN network is made in 100 ohms shielded category 5 cable using either screw terminals, or an RJ45 connector which is similar to the RJ11 connector used to connect to the Mod-hub. The integrity of the cable shield should be maintained throughout the system by having all foil screens or drain wires connected together. A terminal on each T640 loop controller or T221 gateway provides a convenient tie point for the drain wires, while the shield of the RJ45 connectors maintains continuity across T103/T303 units.

Arcnet transceivers

The transceivers used on the ALIN nodes have better performance than conventional twisted-pair bus transceivers and a total of 16 nodes can be supported on one bus segment. The Mod-hub has a conventional Arcnet transceiver and up to 8 nodes may be connected to a bus segment connected to a Mod-hub. The connector for the twisted-pair star (-TPS) port is a 4-wire, 6-position RJ11 which is connected to the EPA RJ45 connector system via an adapter cable.

Termination

The -TPS port on the Mod-hub appears as a balanced twisted-pair port with an input impedance of 93 ohms. This port effectively

terminates one end of an ALIN segment since the characteristic impedance of the ALIN cable is 100 ohms. The -TPS port on a Mod-hub expansion module must therefore be connected to the end of an ALIN segment, remembering to omit the end-of-line terminator.

Connecting to the Mod-hub

Refer to the diagram below when connecting the Mod-hub to either the end of an ALIN segment or between two ALIN segments. Observe correct polarity of signals since reverse polarity will cause unreliable operation.

If a connection must be made to the middle of an ALIN segment, cut the ALIN cable, thereby creating two ALIN segments, and use two -TPS ports which each effectively terminate one end of a segment. The far end of each segment will still require passive termination.

Owing to the nature of fibre-optic communications, a duplex arrangement is needed thus necessitating two cores per connection (1 transmit/1 receive).

Expansion to fibre-optic cables

The Mod-hub expansion modules provide four ports each (either twisted-pair or fibre-optic) and up to four expansion modules can be inserted into a Mod-hub-16 chassis. Mixed media modules exist with both twisted-pair and fibre-optic ports. These modules may represent the least expensive method of bridging cable technologies.

Fibre-optic cable types and connectors

There are three common diameters of fibre optic cable that are supported by the Mod-hubs, namely 50/125, 62.5/125 and 100/140 microns. There are also two common types of connector, namely ST and SMA. The first of these is a twist and lock type and gives repeatable performance at a slightly higher price. The SMA type connector is less expensive but is a twist on only and gives a higher insertion loss and lower repeatability since the connector is not guaranteed to be in the same place with respect to the fibre after each mating.

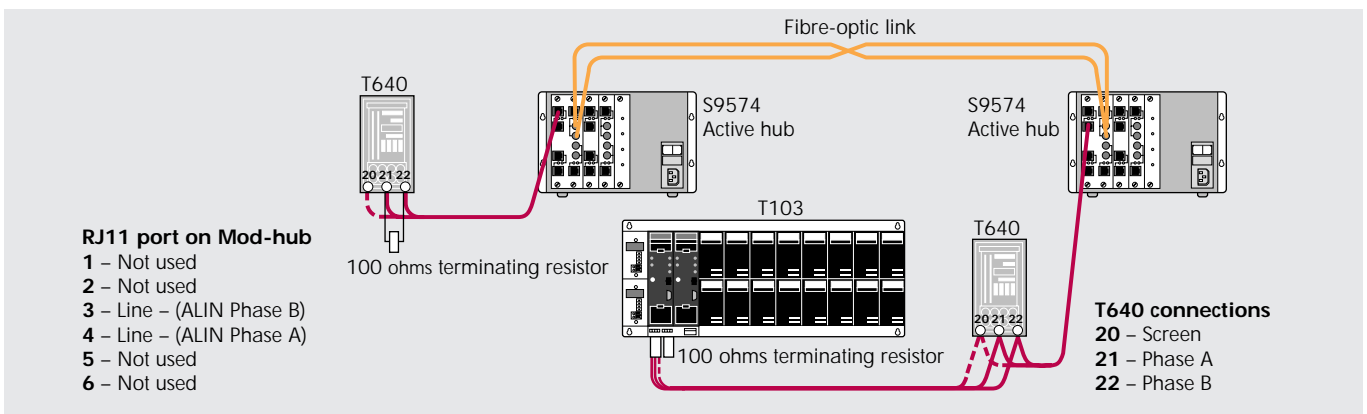

Typical connection diagram using Mod-hubs to extend an ALIN segment

SPECIFICATIONS

General

CE	CE conforms to EMC Directive 89/336/EEC amended by 93/68/EEC, and also with the Low Voltage Directive 72/23/EEC
Safety:	EN60950
EMC emissions:	EN55022:1995 Class A
EMC immunity:	EN50082-2 Industrial environment
Operating temperature:	0 to +60°C
Storage:	-40 to +85°C
Supply voltage:	120V nominal: 92-132V RMS 50/60Hz 230V nominal: 184-264V RMS 50/60Hz
Input power:	0.5A @ 120V 0.25A @ 230V
Isolation:	Individual transformer isolation on each ALIN port; note that the cable screens should be connected to chassis via shielded connector to ensure EMC conformance

Node capacity and cable lengths

	Cable	Connector	Length/Segment	Notes
Twisted-pair bus:	Cat 5 (shielded)	RJ45 ¹	100m	8 nodes max
Glass fibre-optic:	50/125 ²	SMA or ST	915m	Point to point pair
	62.5/125	SMA or ST	1825m	Point to point pair
	100/140	SMA or ST	2740m	Point to point pair

Notes:

1. RJ11 on Mod-hub
2. 62.5/125 cable generally preferred

Basic ALIN specifications

Data rate:	2.5Mb/s
Access method:	Token passing
Max node addresses/network:	254
Max electrical nodes per drop:	Up to 16, 8 if connected to a Mod-hub
Max distance:	5000m approx (with fibre-optic cable and repeaters)

Note: The total combined transmission distance using fibre-optic cable and multiple hubs depends on the signal propagation delay along the transmission media.

Propagation delays

Max one-way delay for	
ALIN segment:	31µs
Active-hub:	0.25µs
Cat 5 cable:	5.7ns/m
Fibre-optic cable:	5ns/m

DIMENSIONS

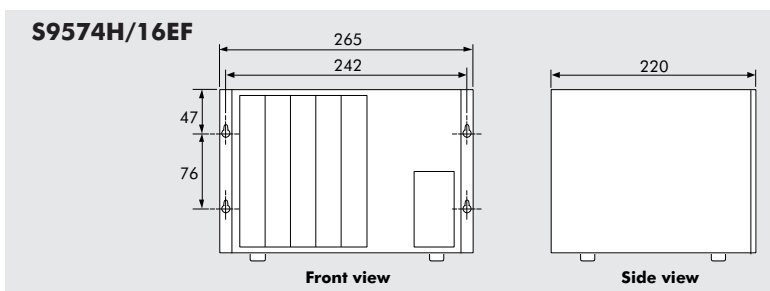

ORDERING INFORMATION

S9574H ALIN active hub

Base unit	Mounting	Power supply		
S9574H	16EF	230V		

Example

Base unit	Code
ALIN active hub	S9574H

Mounting	
16-port free-standing	16E
16-port bulkhead mounting	16EF

Power supply	
120V supply 50/60Hz	120V
230V supply 50/60Hz	230V

Note: Up to four 4-port cards per hub

S9574C ALIN active hub interface cards

Base unit	Connection			
S9574C	TP			

Example

Base unit	Code
Interface card for ALIN active hub	S9574C

Connection	
4-port fibre-optic glass with SMA connector	FO-SMA
4-port fibre-optic glass with ST connector	FO-ST
4-port twisted-pair with RJ11 connector	TP
2-port fibre-optic glass pair with SMA connector and 2-port twisted-pair with RJ11 connector	TPFO-SMA
2-port fibre-optic glass pair with ST connector and 2-port twisted-pair with RJ11 connector	TPFO-ST

Note: ST connector preferred over SMA unless otherwise specified

S9508-5 ALIN cable

Base unit	Connection			
S9508-5	RJ11-45X			

Example

Cable types	Code
ALIN cable Cat 5 shielded 100Ω	S9508-5

Connection	
RJ11-45 adapter, crossed (to T103/T303, PCALIN)	RJ11-45X
RJ11 to ferrules, crossed (to T640, T221)	1RJ11X
RJ11-RJ11, direct (Active hub to Active hub)	2RJ11D
RJ11-RJ11, crossed (to PC card adapter)	2RJ11X

Fibre-optic cable: Installation of fibre-optic cables is a specialist activity – consult factory

EUROTHERM LIMITED <http://www.eurotherm.co.uk>

UK SALES OFFICE
Eurotherm Ltd
Faraday Close Durrington Worthing BN13 3PL United Kingdom
Sales and support: Tel. +44 (0)1903 205277 Fax +44 (0)1903 236465

Sales and support in over 30 countries worldwide
Enquiries/orders to:
Eurotherm Ltd Faraday Close Durrington
Worthing BN13 3PL United Kingdom
Tel. +44 (0)1903 205277 Fax +44 (0)1903 236465

© Copyright Eurotherm Limited 1997, 1998, 2001

All rights strictly reserved. No part of this document may be stored in a retrieval system, or any form or by any means without prior written permission from Eurotherm Limited. Every effort has been taken to ensure the accuracy of this specification. However in order to maintain our technological lead we are continuously improving our products which could, without notice, result in amendments or omissions to this specification. We cannot accept responsibility for damage, injury loss or expenses resulting therefrom.

