Thyristor power units

TC1028 series

Control of Single-phase inductive and resistive loads

User Manual

© Copyright Eurotherm Automation 1996

All rights reserved. All reproduction or transmission in any form or using any procedure (electronic or mechanical, including photocopying and recording) without the written permission of EUROTHERM AUTOMATION is strictly prohibited. EUROTHERM AUTOMATION have taken particular care to ensure the accuracy of these specifications. However, in order to maintain our technological lead, we are dedicated to the continual improvement of our products and this may lead to modifications or omissions in the current specifications. We cannot be held responsible for any material or bodily damage, losses or costs incurred.

The installation, configuration, commissioning and maintenance of the power unit must only be performed by a person **qualified and authorised to perform work in an industrial low voltage electrical environment**.

Important precautions and special information are indicated in the manual by two symbols:



DANGER

This symbol means that failure to take note of the information may have serious consequences for the safety of personnel and may even result in the risk of electrocution.



ATTENTION

This symbol means that failure to take note of the information may

- **have serious consequences for the installation**
- **result in the incorrect functioning of the power unit.**

These marks must indicate specific points.
The entire manual remains applicable.

It is the responsibility of the user and it is highly recommended, given the value of the equipment controlled using TC1028, to install **independent safety** devices.

This alarm must be tested regularly.

Eurotherm can supply suitable equipment.

As a result of the constant improvement of its products, Eurotherm may modify these specifications without warning.
For any further information and if in doubt, please contact your EUROTHERM office where technicians are at your disposal should you require advice or assistance with the commissioning of your installation.

EUROPEAN DIRECTIVES

COMPONENT

TC1028 thyristor unit is a component according to the **Directive 89/336/EEC** designed to be fitted in systems submitted to CE Marking according to the same Directive.

It is the responsibility of the installer to **affix** the CE Mark and to **establish** the CE declaration of conformity of its overall system in relation to the applicable European Directives.

In order to facilitate the integration of our components in the systems concerned by the CE Mark, Eurotherm has taken the following measures :

SAFETY

For **safety**, the **TC1028** products **installed and used in compliance with this manual** meet the essential requirements of the **Low Voltage Directive 73/23/EEC** of 19/02/73 (amended by the Directive 93/68/EEC of 22/07/93) according to their design.

ELECTROMAGNETIC COMPATIBILITY

For **Electromagnetic Compatibility**, a distinction is made between immunity and conducted and radiated emissions.

Immunity

For immunity, the **TC1028** products **installed and used in compliance with this manual** meet the essential requirements of the **Electromagnetic Compatibility Directive 89/336/EEC** of 03/05/89 (amended by the Directives 92/31/EEC of 12/05/92 and 93/68/EEC of 22/07/93) according to their design.

Radiated emission

For radiated emission, the **TC1028** products **installed and used in compliance with this manual** meet the essential requirements of the above mentioned **Electromagnetic Compatibility Directive** according to their design.

Conducted emission

To reduce the noise due to the utilization of its thyristor units, Eurotherm can supply specific filters. The purpose of these filters is to help you to filter your system and to make it compliant with the essential requirements of the **Electromagnetic Compatibility Directive**.

A declaration attesting the above mentioned statements is available on request.

MARKED APPARATUS

Eurotherm can supply equipment made of a thyristor unit and a filter that both form a **CE Marked apparatus** and is intended to be used in an installation.

For the filter application contact your Eurotherm office.

Please, also refer to the installation guide of the filters.

In order to guarantee the best service, Eurotherm **have validated the compliance** of the TC1028 with the essential European Directive requirements **through product design and laboratory tests** described in a technical file for attention of official authorities.

A declaration of compliance with the European Directives is available on request.

ENVIRONMENT

The electromagnetic compatibility of the TC1028 has been specially developed for the **industrial environment** and must not be used in residential type environments.

For further details, contact your Eurotherm office.

This TC1028 User Manual, Part N° **HA 174804 ENG**, (old Part N° HA174805) intends for the **TC1028** series power thyristor units manufactured **from January 1996**.

For the products manufactured **before** this date, no user manual is existing. Please, refer to the **maintenance** manual Part No. HA 173328.

In order to help you reduce risks related to the effects of electromagnetic interference depending on the installation of the product, Eurotherm can supply you with the "**EMC Installation Guide**" (Part No. HA 025464).

This guide gives the rules generally applicable for Electromagnetic compatibility.

Manufactured by Eurotherm Automation S.A.
ISO 9001 - EN 29001 certified

TC1028 USER MANUAL

The safety instructions for the installation and use of TC1028 series units are given on the following pages:

- **installation** 2-2
- **cabling** 3-2, 3-5, 3-9, 3-11
- **configuration** 4-2
- **commissioning** 6-2, 6-3, 6-13
- **protection with fuses** 7-2
- **maintenance** 7-5

TC1028 USER MANUAL

Contents

Chapter 1	IDENTIFYING THE THYRISTOR UNITS	Page
	General introduction to the TC1028 series	1-2
	Technical data	1-7
	Coding	1-10
	Coding example	1-11
	Serial number labels	1-12
Chapter 2	INSTALLATION	
	Safety during installation	2-2
	Dimensions	2-3
	Mechanical mounting	2-5
	Installation details	2-6
Chapter 3	CABLING	
	Safety during cabling	3-2
	Fixing the power cables	3-3
	Reference voltage connection	3-6
	Control cables	3-7
	Fixing	3-7
	Connection of the shield to the ground	3-8
	Control terminal block	3-9
	Input signals	3-11
	External analogue input	3-12
	Control of multiple thyristor units	3-13
	Parallel configuration	3-13
	Serial configuration	3-14
	Manual control configuration	3-15
	External current limit configuration	3-16
	Retransmission signal configuration	3-18
	Single-phase load wiring diagram	3-19
	Three-phase load wiring diagram	3-20
	Load in star with neutral	3-21
	Load in open delta	3-22
	Load in star without neutral or in closed delta (2 phase control)	3-23
	PLF alarm signalling	3-24

Contents (Continued)

Page

Chapter 4 CONFIGURATION

Safety during configuration	4-2
Power board	4-3
Voltage selection	4-3
Driver board	4-4
Input signal	4-5
Control signal type	4-5
Input configuration	4-5
Thyristor firing mode	4-6
RMS current retransmission	4-7
Frequency	4-8

Chapter 5 OPERATION

Thyristor firing modes	5-2
General	5-2
"Phase angle" mode	5-2
"Burst firing" mode	5-3
"Single cycle" mode	5-3
Modulation period	5-4
Soft start / end	5-5
Over-current elimination for the inductive load	5-6
Feedback	5-7
Feedback function	5-7
Supply voltage variation compensation	5-8
Selective trigger pulse blocking	5-9
Current limit	5-10
Linear current limit	5-10
Threshold current limit	5-11
Partial load failure detection	5-12
Retransmission	5-13
Retransmission signal	5-13
Load current image	5-13
Load voltage image	5-13
Bargraph indication	5-13
Enable / Inhibition	5-14
"Master-Slave" operation	5-14

Contents (Continued)

Chapter 6 COMMISSIONING PROCEDURE	Page
Commissioning procedure safety	6-2
Checking the characteristics	6-3
Load current	6-3
Supply voltage	6-3
Reference voltage	6-4
Input signals	6-4
Partial load failure detection	6-4
Diagnostic unit	6-5
Preliminary adjustments	6-8
Resistive load with low resistance variations	6-10
Resistive load with high resistance variations	6-10
Inductive load	6-11
Partial load failure detection adjustment	6-12
Current limit adjustment	6-13
Linear limit	6-13
Threshold limit	6-14
Checks in the event of abnormal operation	6-15

Chapter 7 MAINTENANCE

Thyristor protection	7-2
Thyristor protection fuse	7-3
Fuse blown indication micro-switch	7-4
Protection fuses for reference voltage connection	7-5
Servicing	7-5
Tools	7-6

Chapter 1

IDENTIFYING THE THYRISTOR UNITS

Contents	page
General introduction to the TC1028 series	1-2
Technical data	1-7
Coding	1-10
Coding example	1-11
Installation parameters	1-11
Thyristor unit coding	1-11
Serial number labels	1-12

Chapter 1 IDENTIFYING THE THYRISTOR UNITS

GENERAL INTRODUCTION TO THE TC1028 SERIES

The **TC1028** series power thyristor units are designed for the **control** of industrial **single-phase** loads.

The **TC1028** series is designed to control:

- inductive loads (transformer primary circuits, in particular) or
- **high** temperature coefficient resistive loads.

A thyristor unit contains a pair of **thyristors** mounted in antiparallel on a heat dissipator.

The **TC1028** series thyristor units control currents between **300 A** and **500 A**.

The nominal line to line voltage varies between **100 V** and **480 V**.

The control signal, which can be reconfigured by the user, has four voltage levels:

0-5 V ; 0-10 V ; 1-5 V ; 2-10 V,
and two current levels:

0-20 mA ; 4-20 mA.

Manual control using external potentiometers is possible.

The **TC1028** series is equipped with the following functions:

- electrical power control of inductive and resistive loads
- different thyristor firing modes
- decrease in the current requirement of high temperature coefficient loads for soft starts
- elimination of over-currents when starting inductive loads
- current limit
- partial load failure detection
- logic output to control other power units ("Slave firing" output)
- selective pulse locking circuit
- inhibition available on the user terminal block
- load current and voltage image retransmission
- current level display using a bargraph on the front fascia.

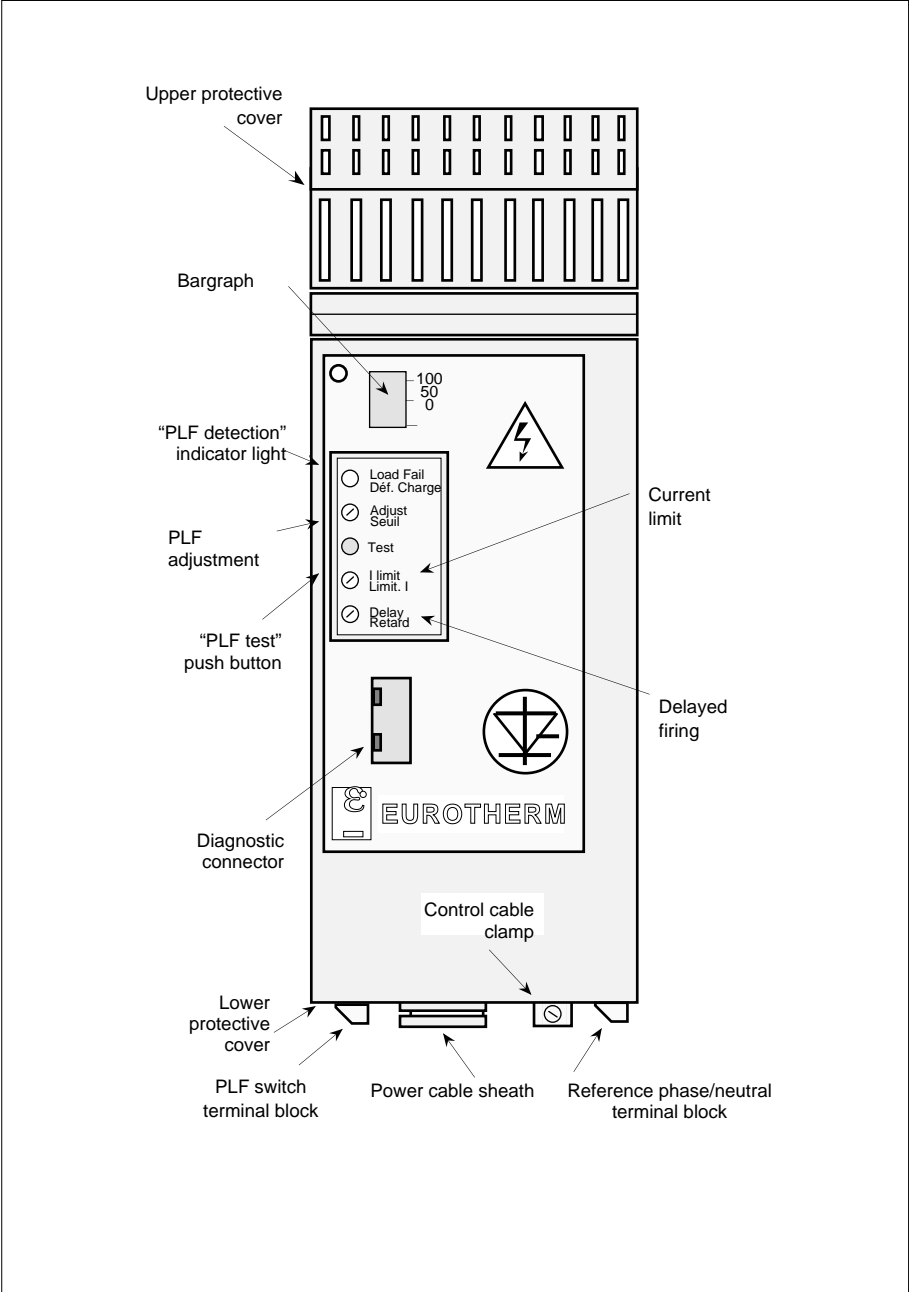

Figure 1-1 Overall view of the TC1028 series thyristor unit

The standard version (**basic version**) of the **TC1028** series thyristor unit is equipped with:

- a thyristor firing board ("**power board**") which generates the thyristor firing and current and voltage measurement pulses;
- a "**driver board**" which generates the firing start signals;
- a "**potentiometer board**" for the adjustment of the delayed thyristor firing (for inductive loads) and the soft start time.
- a "**filter board**" to protect the thyristor unit operation against transient interference.

As an option, the **TC1028** power thyristor unit can be equipped with a board which be plugged into the driver board and converts the instantaneous current into an image of the RMS current ("**RMS option board**"). The rms value of the load current is displayed using a bargraph and is retransmitted by a signal from the user terminal block.

The control system performs, as a function of an analogue input signal, the feedback of the squared voltage or the squared load current (automatic selection of the highest value).

The TC1028 thyristor units possess supply variation compensation in the range of **+10 %** to **-15 %** of the nominal voltage.

The TC1028 series thyristor units are used to control electrical loads such as:

- loads with high resistance variations as a function of temperature
- transformer primary circuits
- inductors.

The following are found on the **front fascia**:

- the **delay adjustment** potentiometer for the first firing on inductive loads or soft start adjustment potentiometer
- the connector for **diagnostics**
- the **bargraph** indicating the mean current of the rms current (optional)
- the partial load failure detection **adjustment** potentiometer
- the "**Test**" push button to test the PLF alarm adjustment
- the **indicator light** to display the partial load failure detection.

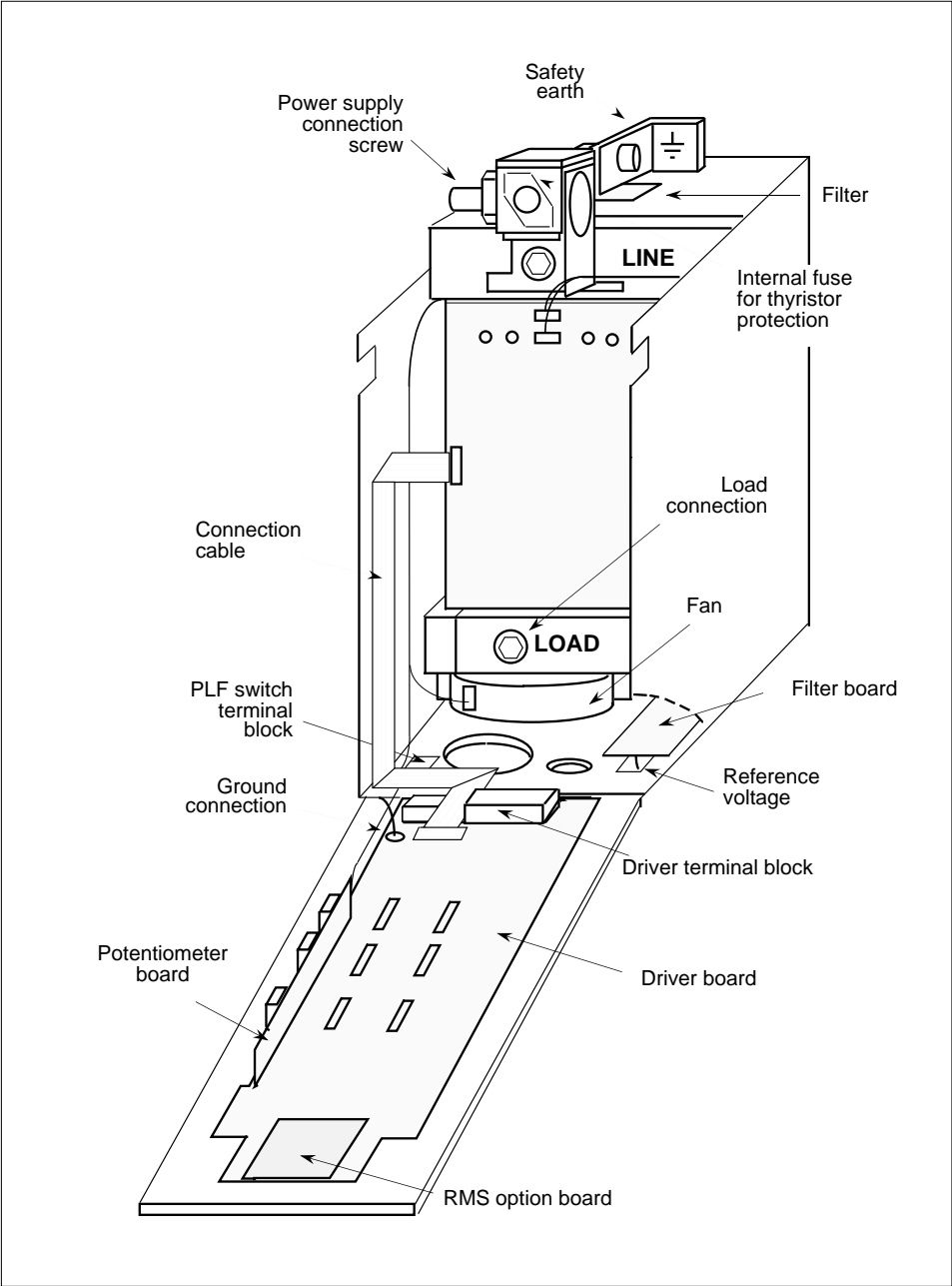

Figure 1-2 TC1028 series thyristor unit electronic boards

The **TC1028** thyristor units have the following thyristor **firing** modes:

- thyristor firing angle variation ("**Phase angle**"),
- cyclic firing ratio modulation from 0 to 100 % ("**Burst mode**").

"**Burst mode**" firing is characterised by different modes:

- a firing or non-firing cycle ("**Single cycle**")
- **slow** cycle (modulation time **10 s** at 50% setpoint)
- **fast** cycle (modulation time **0.6 s** at 50% setpoint)
- burst firing (fast or slow) with **soft start** in thyristor firing angle variation
- burst firing (fast or slow) with **soft start and end** in thyristor firing angle variation.

The soft start for high temperature coefficient resistive loads and the delayed firing angle at the first alternation in the case of the control of inductive loads (which may cause fuse blow-out or trigger the protective circuit breaker) **minimise transient over-currents**.

The soft start and end time can be adjusted between **0** and **0.25 s** using the potentiometer on the front fascia.

The **TC1028** power thyristor units have two types of current limit:

- **linear** limit (adjustment using potentiometer on front fascia)
- **threshold** limit (adjustment using external potentiometer).

The partial load failure (**PLF**) detection circuit detects 25 % increases in load impedance (independently from the supply voltage variation).

The PLF detection is adjusted using a potentiometer on the front fascia for the real load current used.

The PLF alarm is signalled by the alarm relay **switch** and by the "**Load Fail**" indicator light on the front fascia.

Thermal protection is provided by a thermal switch which detects if the fan has stopped or the heatsink is overheated.

The TC1028 thyristor unit is equipped with **active operation validation**.

An external **10 V** voltage (32 V max) or a switch connected to the user terminal block is used to validate the thyristor unit operation.

The absence of the validation voltage or the opening of the switch causes the **inhibition** of the thyristor unit.

TECHNICAL DATA

The TC1028 is a power thyristor unit designed to control an industrial single-phase load with a high current requirement at start-up using thyristors.

Attention !



It is the user's responsibility to ensure that the nominal values of the thyristor unit are compatible with the conditions of installation and operation before commissioning the thyristor unit.

Power

Nominal current	300 A, 400 A, 500 A
Nominal line to line voltage	100 Vac to 480 Vac (+10%,-15%) Inhibition below 80% of the nominal voltage; response time <10 ms; automatic reset 2 s after return to nominal
Supply frequency	50 or 60 Hz (± 2 Hz)
Dissipated power	1.3 W (approximately) per ampere
Cooling	Permanent fan cooling
Fan	Consumption 6.5 W (24 V dc fan). Auto-power supply by the power circuit.
Load	Resistive with high temperature coefficient or inductive (transformer primary circuit or inductor).

Environment

Operating temperature	0°C to +50°C in vertical position (+40°C for 500 A nominal current; at +50 °C redimension to 450 A)
Storage temperature	-10°C to +70°C
Protection	2 covers providing IP20 protection on the front fascia
Thyristor protection	Internal high speed fuse , in fuse blown indication micro-switch option Varistor and RC snubber
Cabling	To be performed according to the standards IEC 364
Atmosphere	Non-explosive, non-corrosive and non-conducting
Humidity	RH of 5% to 95% without condensation
Pollution	Degree 2 admissible, defined by IEC 664
Altitude	2000 m maximum
Dimensions	570 mm (H) x 248 mm (W) x 268 mm (D) Wt. 16.5 kg .

Control

Power supply	Auto-power supply from the power circuit. Connection of a reference phase (or neutral). Consumption: 20 VA
Signal type	Analogue
Setpoint	Voltage: 0-5 V; 1-5 V; 0-10 V or 2-10 V Current: 0-20 mA; 4-20 mA
Input impedance	Voltage: $\geq 50 \text{ k}\Omega$ Current: 250 Ω
Manual control	5 kΩ external potentiometer
Thyristor firing modes	The following can be reconfigured by the user: <ul style="list-style-type: none"> • Phase angle • Single cycle (burst firing with a firing or non-firing cycle) • Fast cycle (typical modulation time at 50 % power: 0.6 s) • Slow cycle (typical modulation time at 50 % power: 10 s) • Fast cycle with adjustable soft start between 0 and 250 ms (with or without soft end) • Slow cycle with adjustable soft start between 0 and 250 ms (with or without soft end)
Delayed thyristor firing	For inductive loads, the delayed firing of the first alternation of the burst mode firing (without soft operation) eliminates transient currents
Validation / Inhibition	Using external switch or external voltage. Response: validation 2 s ; inhibition < 25 ms
Diagnostics	Connector for diagnostic unit used to adjust and control the thyristor unit using 20 test signals
Feedback type	Squared load current or squared voltage control. Supply variation compensation .
Configuration	Shielded cable connected to the ground at both ends.
Connection	0.5 mm² to 1.0 mm² wires Tightening 0.5 N.m

RMS option board

Retransmissions	RMS load current. dc signal (0 to 10 V) proportional to the real load current image.
Display	Retransmission output on the user terminal block. Display of RMS current using 10 segment bargraph.

Current limit

Linear limit	Proportional load current limit (20 % to 100 % of the nominal current). Adjustment using potentiometer on front fascia.
Threshold limit	Maximum load current limit. Adjustment possible using an external potentiometer.

Partial load failure detection

Alarm	20% current decrease detection. Adjustment on front fascia using " Adjust " potentiometer.
Test	Using front fascia " Test " push button.
Signalling	" Load Fail " indicator light on the front fascia. Alarm relay switch open in alarm status (in standard version) Switch closed in alarm status (IPF option).

Bargraph

Display	<ul style="list-style-type: none"> • Instantaneous current (filtered mean value) to adjust the first thyristor firing for inductive loads (basic version). • RMS value of the load current in "Phase angle" and "Fast cycle" firing modes with or without soft start or end (with RMS option board).
---------	-------------------------------------------------------------------------------------------------------------------------------------------------------------------------------------------------------------------------------------------------------------------------------------------------------------------------------------

Attention !

Due to the continual improvement of products, Eurotherm may be required to modify specifications without prior notice. For any further information and in the event of doubt, contact your Eurotherm Office.



CODING EXAMPLE

TC1028 thyristor unit and installation parameters

Nominal load current	250 amperes
Nominal supply voltage	440 volts line to line
Analogue input signal	0 - 10 volts
Firing mode	"Fast cycle" burst mode firing with soft start.
Options:	"Partial load failure" alarm relay switch closed in alarm status. Fuse blown indication micro-switch . RMS current display and retransmission.

Thyristor unit coding

TC1028 / 300A / 440V / 0V10 / SFC / IPF / RMS / FUMS / 00

Attention !

The nominal voltage of the **TC1028** thyristor unit must correspond to the supply voltage used to prevent problems of **non-operation** for voltages **lower than 80%** of the nominal voltage.

SERIAL NUMBER LABELS

Two **identification** labels (specifying the **coding** of the thyristor unit) and a **configuration** label provide all the information relating to the factory settings of the thyristor unit.

An identification label is **externally** located on the right-hand side panel of the unit.

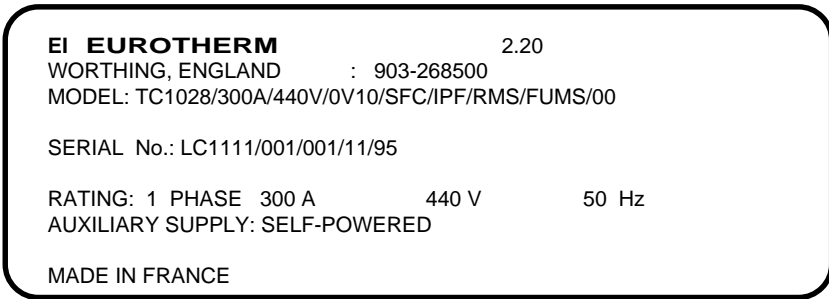

Figure 1-3 Example of identification label for a TC1028 model thyristor unit
The information corresponds to the coding example

The second identification label and a configuration label are located **inside** the thyristor unit.

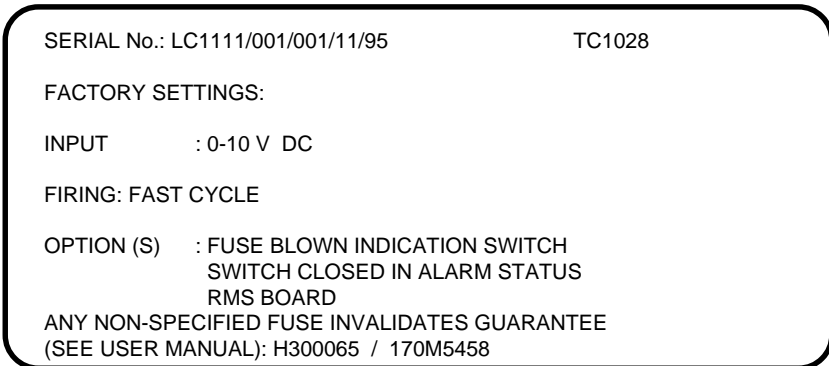

Figure 1-4 Example of configuration label for a TC1028 thyristor unit

Attention !



Following any reconfiguration on the part of the user, there is no guarantee that the thyristor unit and this information corresponds to the information related to the unit coding.

Chapter 2

INSTALLATION

Contents	page
Safety during installation	2-2
Dimensions	2-3
Mechanical mounting	2-5
Installation details.....	2-6

Chapter 2 INSTALLATION

SAFETY DURING INSTALLATION

Danger !



TC1028 units must be installed by a person authorised to work in an industrial low voltage electrical environment.

Units must be installed in fan-cooled electric cabinets, guaranteeing the absence of condensation and pollution.

The cabinet must be closed and connected to the safety ground in accordance with the standard IEC 364 or the current national standards.

For installations in fan-cooled cabinets, it is recommended to place a fan failure detection device or a thermal safety control in the cabinet.

Bulkhead mountings are possible with **TC1028** series units.

The units must be mounted with the heatsink positioned vertically and with no obstructions either above or below which could block the passage of the ventilation air.

If multiple units are installed in the same cabinet, they should be arranged in such a way that the air expelled by one unit cannot be admitted into the unit located above it.

Attention !

The units are designed to be used at an ambient temperature less than or equal to **50°C** (40°C for 500 A nominal units).

Leave a minimum space of **5 cm** between two units placed beside each other.



Excessive overheating may cause incorrect operation of the unit, which in turn may cause damage in the components.

TC1028 series power units have **permanent** fan cooling.

DIMENSIONS

The dimensions, values and weights of the TC1028 series thyristor units are given in figure 2-1 and in table 2-1.

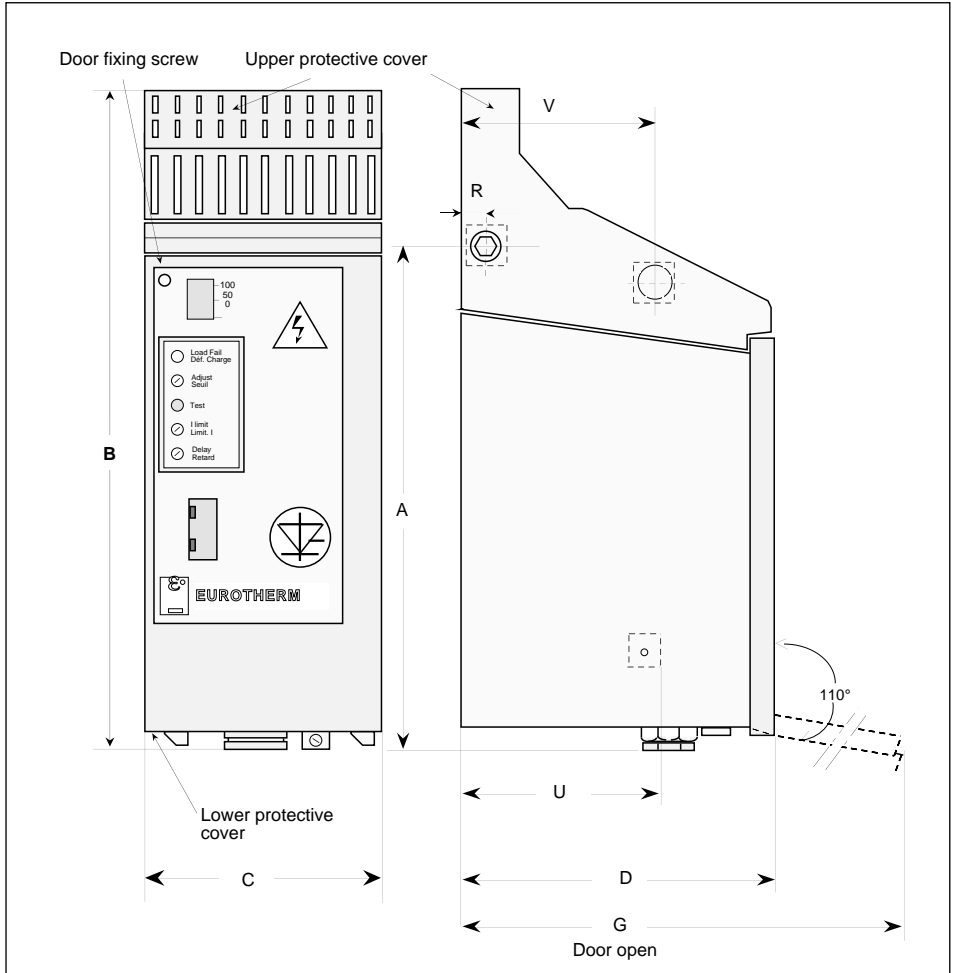

Figure 2-1 Overall dimensions with and without upper protective cover

Values	Dimensions	Description
A	425 mm	Height without protective cover
B	570 mm	Height with cover
C	133 mm	Width
D	268 mm	Depth
E	88 mm	Width between the fixing holes
F	328 mm	Height between the fixing holes
G	557 mm	Depth with the door open
K	350 mm	Height of lateral fascias
R	20 mm	Distance between "Earth" busbar and panel
U	150 mm	Depth between "LOAD" terminal and panel
V	170 mm	Depth between "LINE" terminal and panel
Weight	10 kg	

Table 2-1 Dimensions, fixing values and weight of TC1028 series units

MECHANICAL MOUNTING

TC1028 units have two protective covers (upper and lower).

The units can be fixed with the protective covers in place.

However, for the connection, the upper protective cover must be removed.

After drilling the support panel at the dimensions and values given above, insert the fixing screws half-way in the partition holes or mounting plate.

Position the thyristor unit by first inserting the upper screw heads in the respective holes of the upper section.

Lower the unit making sure that the lower screws can be inserted correctly.

Then lower the unit completely until it is in position.

Fasten the 4 screws correctly.

INSTALLATION DETAILS

TC1028 series units are designed to be mounted directly on panels at the fixing points located on the rear of the unit.

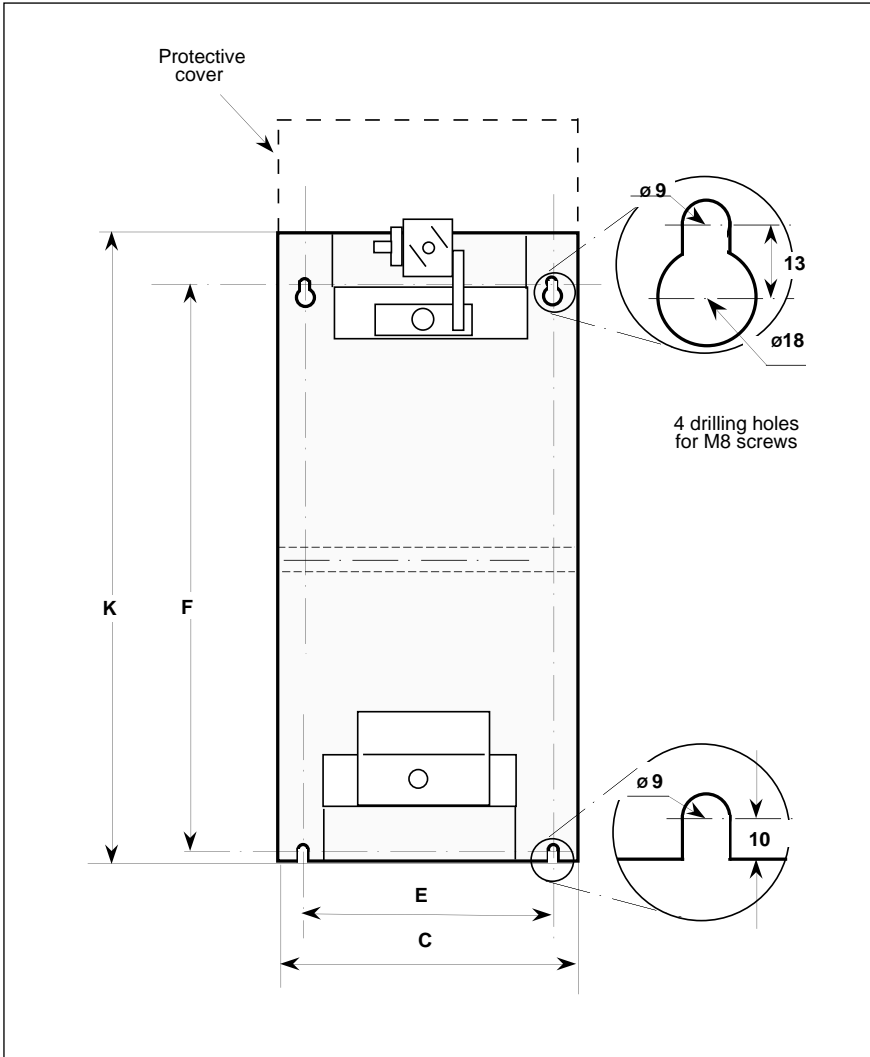

Figure 2-2 Fixing details

Chapter 3

CABLING

Contents	page
Safety during cabling	3-2
Fixing the power cables	3-3
Reference voltage connection	3-6
Control cables	3-7
Fixing.....	3-7
Connection of the shield to the ground	3-8
Control terminal block	3-9
Input signals	3-11
External analogue input	3-12
Control of multiple thyristor units	3-13
Parallel configuration.....	3-13
Serial configuration	3-14
Manual control configuration	3-15
External current limit configuration	3-16
Retransmission signal configuration	3-18
Single-phase load wiring diagram	3-19
Three-phase load wiring diagrams	3-20
Load in star with neutral	3-21
Load in open delta.....	3-22
Load in star without neutral or in closed delta (2 phase control)	3-23
PLF alarm signalling.....	3-24

Chapter 3 CABLING

SAFETY DURING CABLING

Danger !



Cabling must be performed by personnel who are qualified to work with low voltage electrical equipment.

It is the user's responsibility to cable and protect the installation in accordance with current professional standards. A suitable device guaranteeing electrical separation of the equipment and the supply must be installed upstream from the unit in order to perform the operation in complete safety.

TC1028 series units possess **two protective covers**: upper and lower.

The upper cover should be raised to facilitate cabling.

After connection and before power-up, put the upper protective cover back in place to ensure the specified **degree of protection**.

Danger !



Before any connection or disconnection, make sure that the power and control cables and wires are separated from the voltage sources.

For safety reasons, the safety earth cable must be connected before any other connection during cabling and the last cable to be disconnected.

The **safety earth** is connected to the screw located on the strip provided for this purpose in the top part of the unit, behind the phase terminal and labelled as follows:



Danger !



Due to **electromagnetic compatibility** requirements, make sure that TC1028 is bolted to the metal ground (panel or cabinet) and going on good electrical contact. If not, it is necessary to add a ground connection not greater than **10 cm** length between the earth and the reference ground connection.

This connection is intended for providing a good earth lead. It cannot be used as a safety earth connection.

FIXING THE POWER CABLES

The **supply side** power cables pass through the opening of the upper protective cover of the TC1028 unit.

The upper covers of the units are raised in order to facilitate the connection of these cables.

For connection, this cover, which is fixed to the unit, must be raised. In order to do this:

- open the door by unfastening the front screw on the top left-hand corner of the door
- raise the door in order to release it from its notches
- open the door completely by pulling it towards you
- remove the upper cover by unfastening its two fixing nuts by sliding it one cm forwards to release the two catches located at the rear and raising it.

The supply side connection is performed on the terminal of the fuse at the upper part of the unit, labelled **LINE** (see figure 3-1).

The **load side** power cables are placed inside the unit through a cable sheath below the unit. The load is cabled on screws located in the bottom part of the unit and labelled **LOAD** (see figure 3-1).

The capacities of the power terminals and cabling screws are given in table 3-1.

Tightening must not exceed the limit values according to the same table.

Terminal	Cabling details
Supply and load Earth cable	185 to 2x150 mm ² 95 to 185 mm ²
Fuse terminal Tightening torque	M10 26 N.m
Load screw Tightening torque	M12 28.8 N.m
Earth screw Tightening torque	M12 28.8 N.m

Table 3-1 Details of power cabling for TC1028 units

The cross-section of the connection wires to be used must correspond to the Standard **IEC 943**.

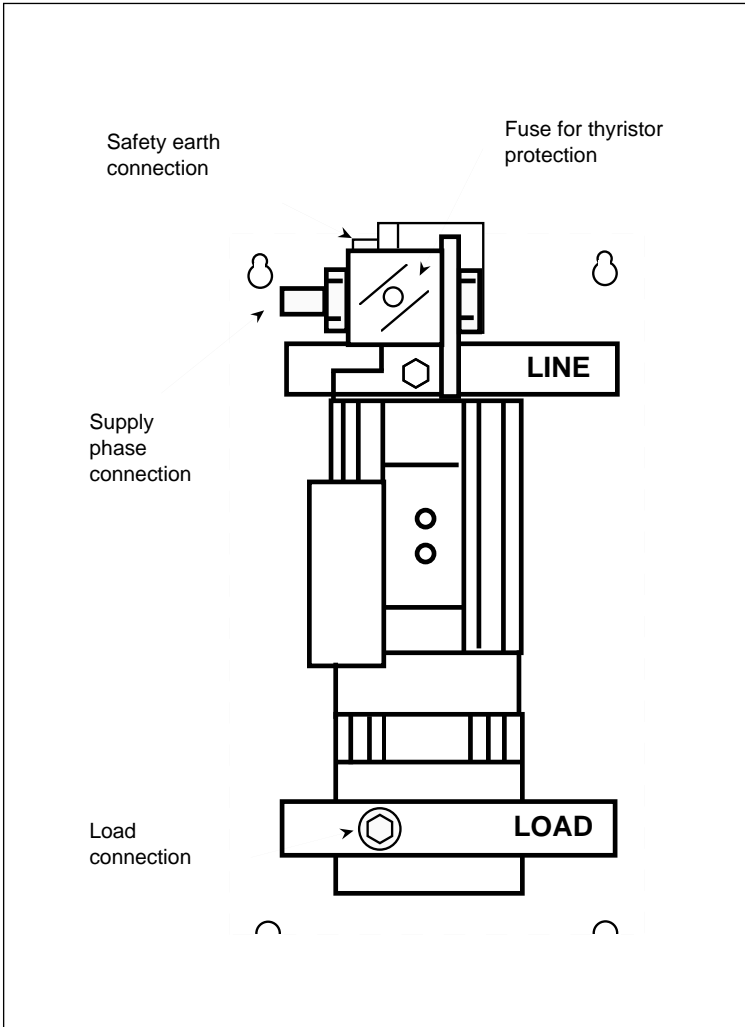

Figure 3-1 Power cable fixing points

Description of distance	Dimension
"Earth" busbar and upper fixing hole	30 mm
"Earth" busbar and left fixing hole	96 mm
"LOAD" terminal and lower fixing hole	70 mm
"LOAD" terminal and left fixing hole	20 mm
"LINE" terminal and upper fixing hole	20 mm

Table 3-2 Power cabling details

Attention !

The power cables to a load pass through **cable sheaths** which must be tightened correctly after cabling.

REFERENCE VOLTAGE CONNECTION

The reference voltage (second phase or neutral), used by the electronics is connected to a plug-in user terminal block, located on the right-hand side below the unit.

The max. wire cross-section is **1.5 mm²**; control terminal tightening: **0.5 N.m**.

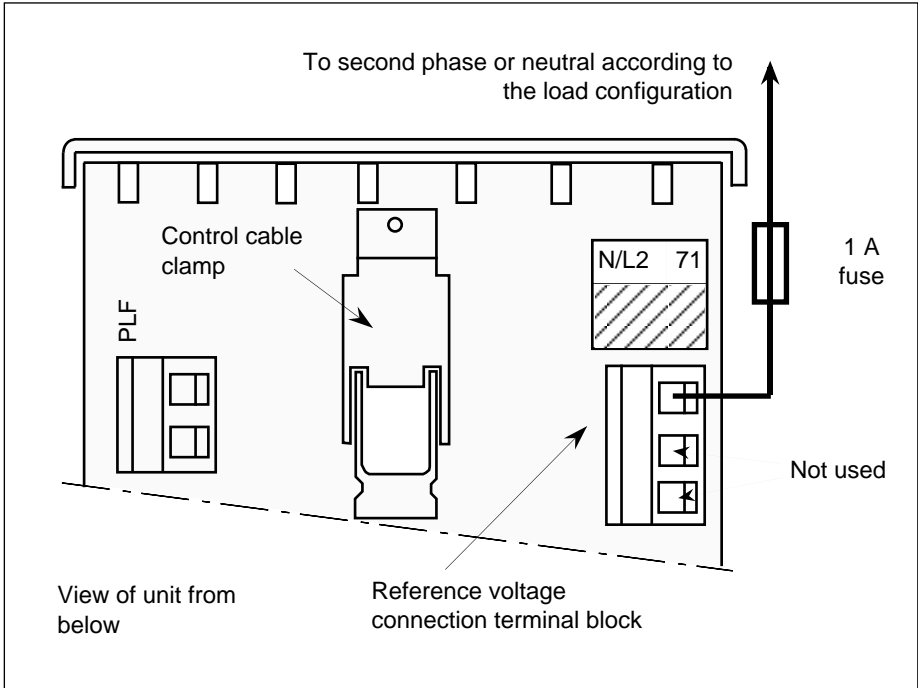

Figure 3-2 Reference voltage connection terminal block

The reference voltage (second phase or neutral) **must correspond** to the **load** configuration voltage.

For the 2 phase control of the three-phase load, the reference voltage is that of the **direct** phase (phase not controlled by the power unit).

A **1 A** external fuse must protect the reference voltage wire.

CONTROL CABLES

Attention!



The control connections must be made with **shielded cables connected to the earth at both ends** in order to ensure satisfactory immunity against interference.

Separate the control cables from the power cables in the cable routes.

Fixing

The control wires must be grouped together in a shielded cable passing through the **control cable clamp** under the unit.

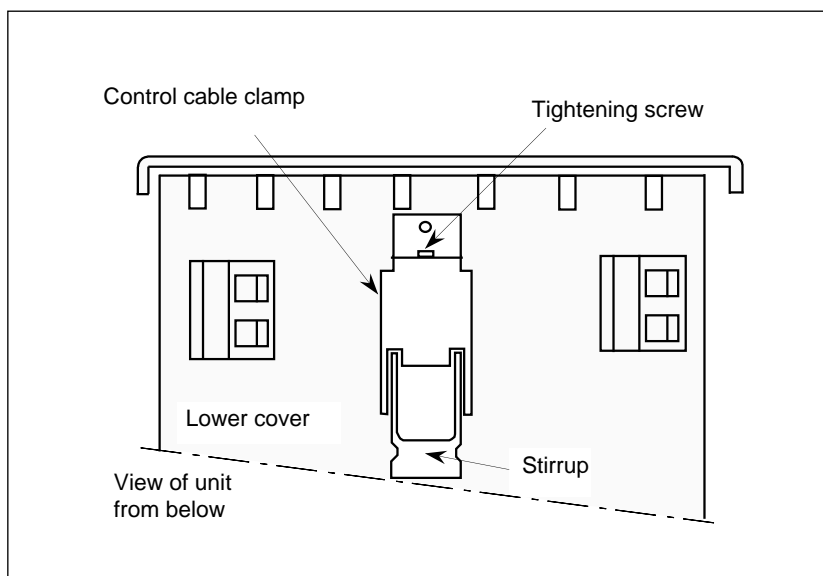

Figure 3-3 Control cable clamp location

Important !

To facilitate the earthing of the cable shield and to ensure maximum immunity to electromagnetic interference, the **metal** cable clamp is **fixed directly to the ground** of the unit.

Connection of the shield to the ground

To **insert** the control cable and **earth** its shield:

- **Strip** the shielded cable as shown in figure 3-4,a.

The control wires must be long enough for the connection between the metal cable clamp and the board user terminal blocks, with the door open.

The cabling inside the unit must be as short as possible.

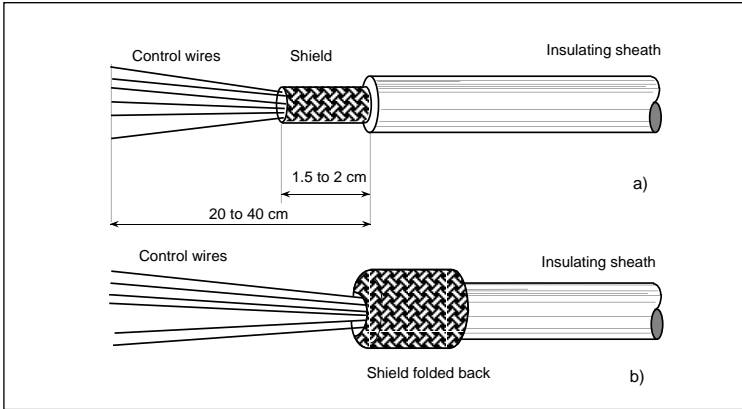

Figure 3-4 Control cable stripping

- **Fold back** the shield on the insulating sheath (figure 3-4,b)
- **Insert** the cable in the metal cable clamp so that the shield is located in the stirrup and does not enter the unit (it must not pass the lower cover).
- **Tighten** the stirrup (4 x 1 flat screwdriver; tightening: **0.7 N.m.**)

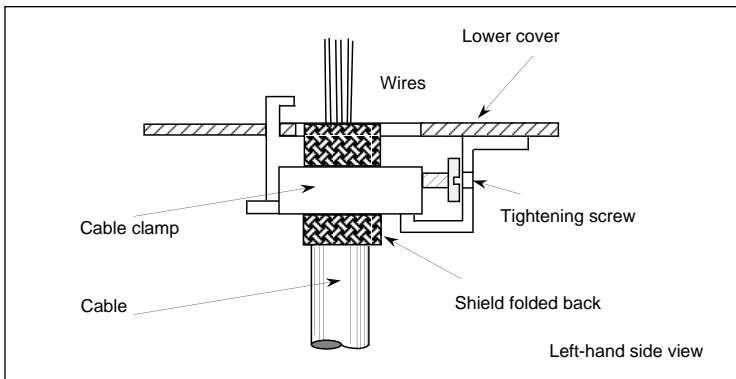

Figure 3-5 Cable tightening and shield grounding

The possible diameters of the cables with the shield folded back are **5 to 10 mm** per cable clamp.

CONTROL TERMINAL BLOCK

The following connections are made on the driver board user terminal block:

- the (external or manual) input signal
- the thyristor unit operation validation
- the threshold current limit
- the load current and voltage retransmission
- the logic signal output to control a solid state contactor in "Master-Slave" operation.

The terminal block can be accessed by opening the **front** door.

Danger !



Dangerous live parts may be accessible when the door is open if the TC1028 thyristor unit power is on.

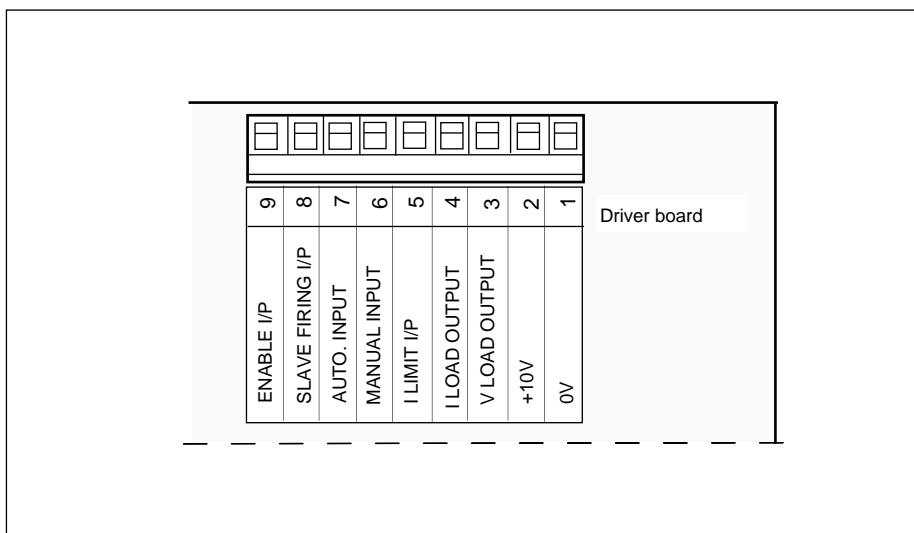

Figure 3-6 TC1028 thyristor unit control terminal labelling

Control terminal block terminal capacity **0.22 mm² to 1.5 mm²**.

Control terminal tightening: **0.5 N.m**.

The input is **insulated** from the power supply and from the load circuit.

Terminal	Name on label	Destination
1	0 V	Common 0 V
2	+10 V	+10 V user voltage
3	V LOAD O/P SORTIE U CHARGE	Load voltage image retransmission output
4	I LOAD O/P SORTIE I CHARGE	Load current image retransmission output
5	I LIMIT I/P ENTREE LIMIT.I	Input for the threshold current limit
6	MANUAL INPUT ENTREE MANU	Input for the manual control signal
7	AUTO INPUT ENTREE AUTO	Input for the automatic control signal
8	SLAVE FIRING O/P SORTIE ESCLAVE	Logic output to control other units in "Master-Slave" operation
9	ENABLES I/P ENT.VALIDATION	Enables thyristor firing operation

Table 3-3 TC1028 thyristor unit control terminal block terminal destination

INPUT SIGNALS

The control wires are connected on the pluggable user terminal block, located on the **driver board**.

The control terminal block is accessible with **the front door open**.

To open the door, unfasten the front **screw**, release the door from its notches by raising it and pull it towards you.

Danger !



Dangerous live parts may be accessible when the door is open if the thyristor unit power is on.

The thyristor units can be controlled by an external analogue signal (from a controller or another signal source) or manually by an external potentiometer.

External analogue input

The TC1028 thyristor unit can be configured with the choice of 4 voltage input signals or with 2 current input signals.

Signal type	Signal level	Input impedance
Voltage	0 - 5 V	50 k Ω
	1 - 5 V	
	0 - 10 V	
	2 - 10 V	
Current	0 - 20 mA	250 Ω
	4 - 20 mA	

Table 3-4 TC1028 thyristor unit external analogue input parameters

The external signal is applied to terminals **1** and **7** of the control terminal block ("+" at terminal **7**).

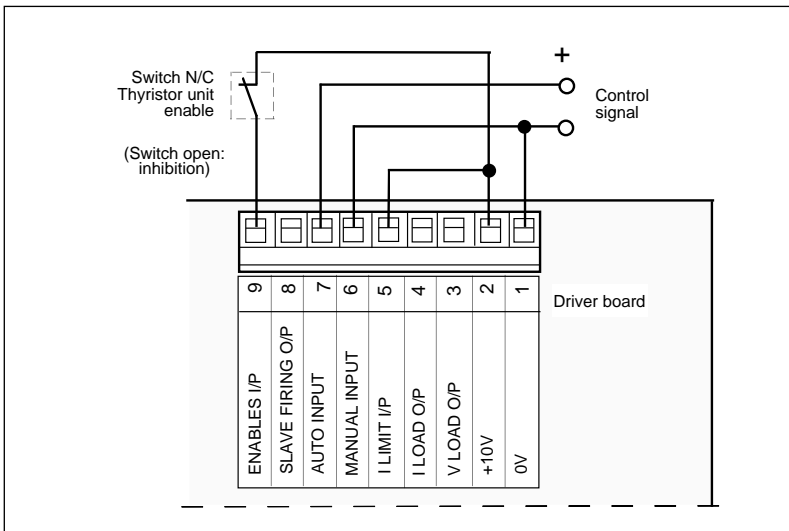

Figure 3-7 External control signal configuration

For the normal operation of the **TC1028** series thyristor unit, also connect:

- the "Enables I/P" input (terminal **9**) at the "+10 V user" voltage (terminal **2**)
- the "I limit I/P" input (terminal **5**) at the "+10 V user" voltage
- "Manual input" (terminal **6**) at terminal **1** "0 V".

Control of multiple thyristor units

Multiple thyristor unit inputs can be configured in **parallel** or in **series**.

For these types of configuration, all the thyristor units must have the same type of firing and the inputs must be configured for the same signal.

Parallel configuration

The inputs must be configured in terms of voltage.

The input impedance for each thyristor unit is **50 k Ω**

The current required for each thyristor unit is **0.2 mA** at full scale.

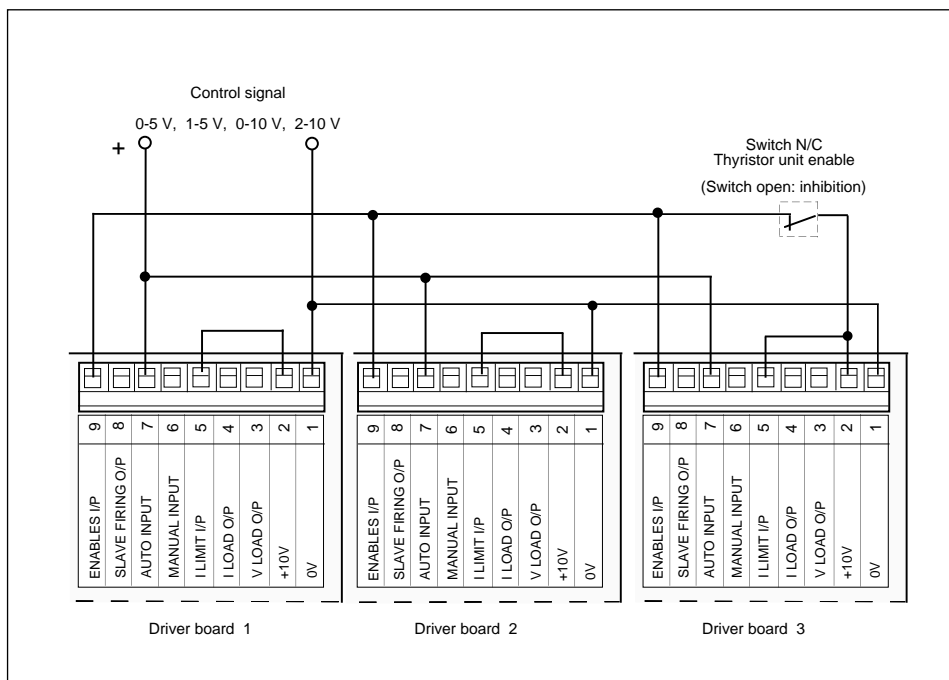

Figure 3-8 Parallel input configuration

Serial configuration

The inputs must be configured in terms of current.

The serial configuration is possible if all the thyristor units are configured for the same current signal (**0-20 mA**, for example).

For the **0-20 mA** and **4-20 mA** inputs, the impedance of an input is **250 Ω**.

For each input, a **5 V** voltage (for the current at **20 mA**) is required.

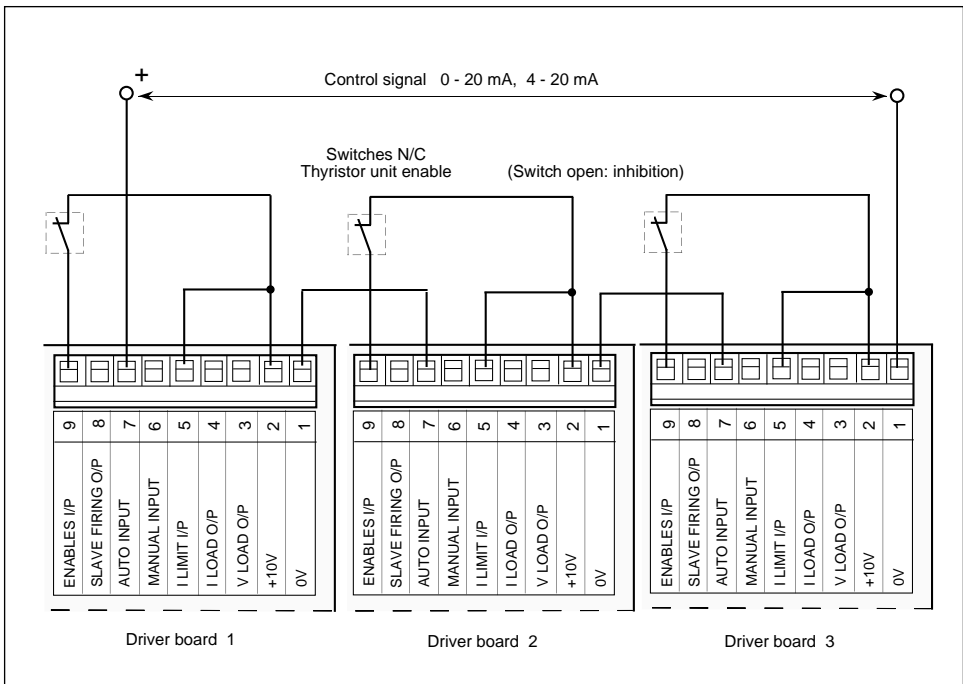

Figure 3-9 Serial input configuration

Manual control configuration

The power thyristor unit can be controlled by an external potentiometer (**manual** control).

This **5 k Ω** external potentiometer must be connected between terminals **1** ("**0 V**") and **2** ("**+10 V**"). The wiper is connected to terminal **6** ("Manual Input").

The power thyristor unit input must be configured to **0-5 V**.

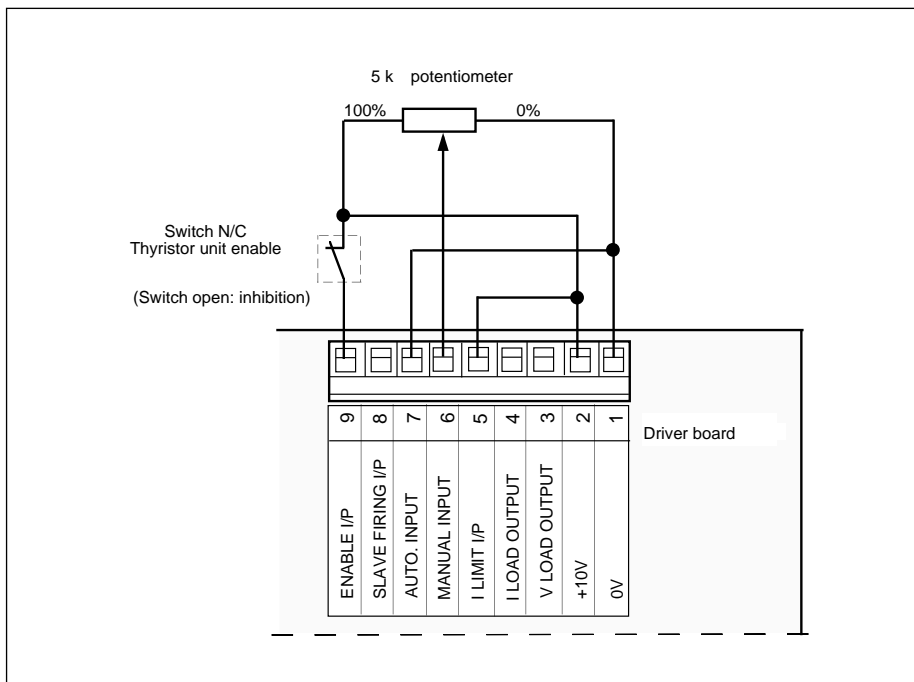

Figure 3-10 TC1028 thyristor unit manual input configuration

When the manual control is used, terminal **7** of the external input labelled "Auto. input" must be connected to "**0 V**" (terminal **1**).

Attention !

If the input signal is not disconnected from terminal **7**, the **2** signals (external and manual) are added together.

External current limit configuration

The **TC1028** power thyristor units use **2** types of current limit (see "Operation" chapter):

- linear limit (internal limit) and
- threshold limit (external limit).

The external limit is controlled by voltage or by the external potentiometer and can be used with the automatic external control and with the manual control.

The external current limit can be adjusted in **3** different ways.

1. External voltage adjustment

For the threshold limit, a **0-10 V** external voltage must be connected between terminals **5** ("**I LIMIT**") and **1** ("**0 V**"), terminal **5** ("**I LIMIT**") is positive.

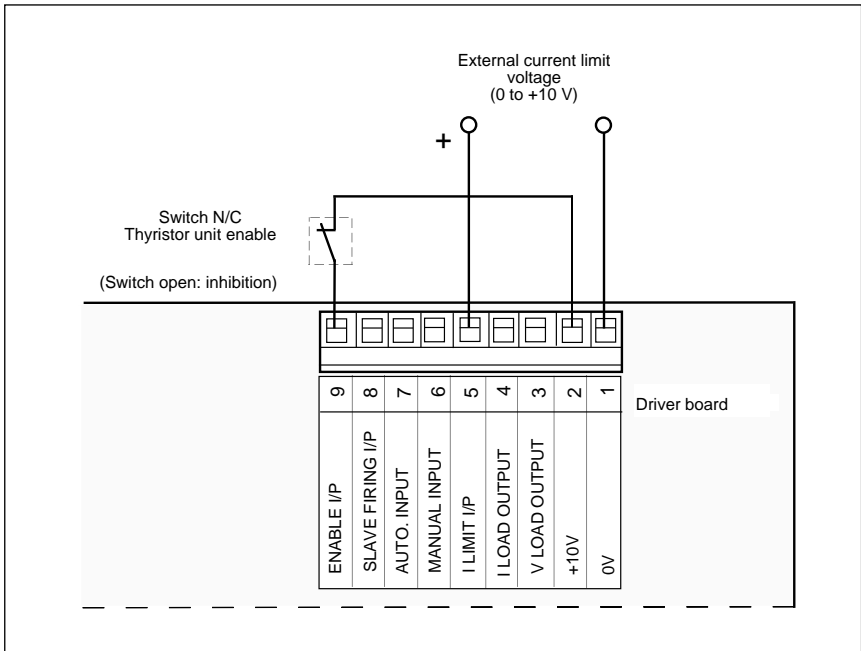

Figure 3-11 External voltage configuration for the threshold current limit

2. Potentiometer adjustment

For the threshold current limit, it is possible to use an external potentiometer.

This **5 k Ω** potentiometer is connected between terminals **1** ("**0 V**") and **2** ("**+10 V**"), its wiper is connected to terminal **5** ("**I LIMIT**").

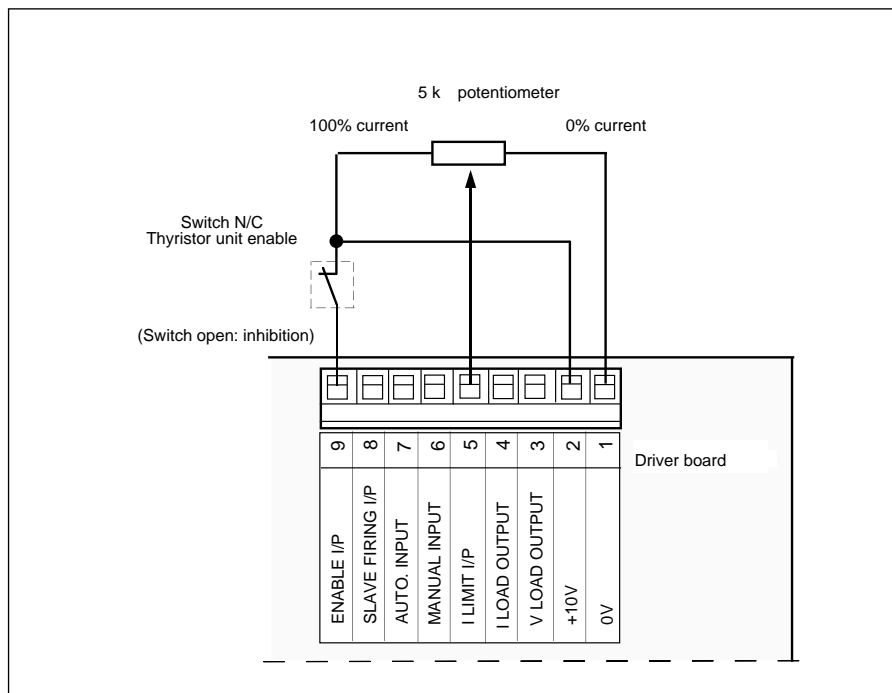

Figure 3-12 External potentiometer configuration for the threshold current limit

3. Fixed external limit

The fixed current limit equal to **110 %** of the thyristor unit nominal current is maintained by connecting the "**I LIMIT**" input (terminal **5**) to "**+10 V**" (terminal **2**).

Attention !

If the external current limit is not used, terminals **5** and **2** must be connected.

Retransmission signal configuration

The load current and voltage images are available on the control terminal block.

The **voltage image** is retransmitted as a double alternation rectified signal which is proportional to the instantaneous value of the load voltage.

The value of this signal is **5 V RMS (4.3 V mean)** for the nominal voltage.

The voltage image is available between terminals **3** ("V Load output") and **1** ("**0 V**").

The retransmission of the **current image** depends on the presence of the RMS option board.

- In the **basic** version (**without** RMS option), the signal available between terminals **4** ("I Load O/P") and **1** ("**0 V**") is a double alternation rectified signal, proportional to the instantaneous value of the load current.
The value of the retransmitted signal is **5 V RMS (4.3 V mean)** for the thyristor unit nominal current.
- With the **RMS** option, the retransmitted signal between terminals **4** and **1** of the driver board is proportional to the **TRMS** value of the load current.
The value of this signal is **10 V** for the thyristor unit nominal current.

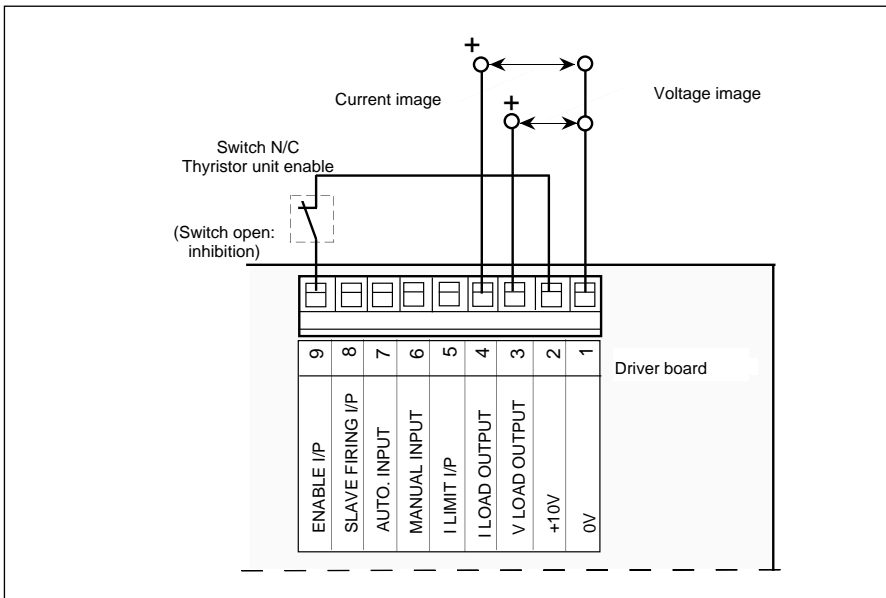

Figure 3-13 Retransmission signal configuration

The current image signal (with or without the **RMS** option) is displayed by the bargraph on the front fascia of the thyristor unit. This bargraph has **10** segments; each segment represents **10 %** of the **thyristor unit nominal** current.

SINGLE-PHASE LOAD WIRING DIAGRAM

The wiring diagram of the power, safety earth and reference voltage of the TC1028 series thyristor unit for the control of a single-phase load is given below.

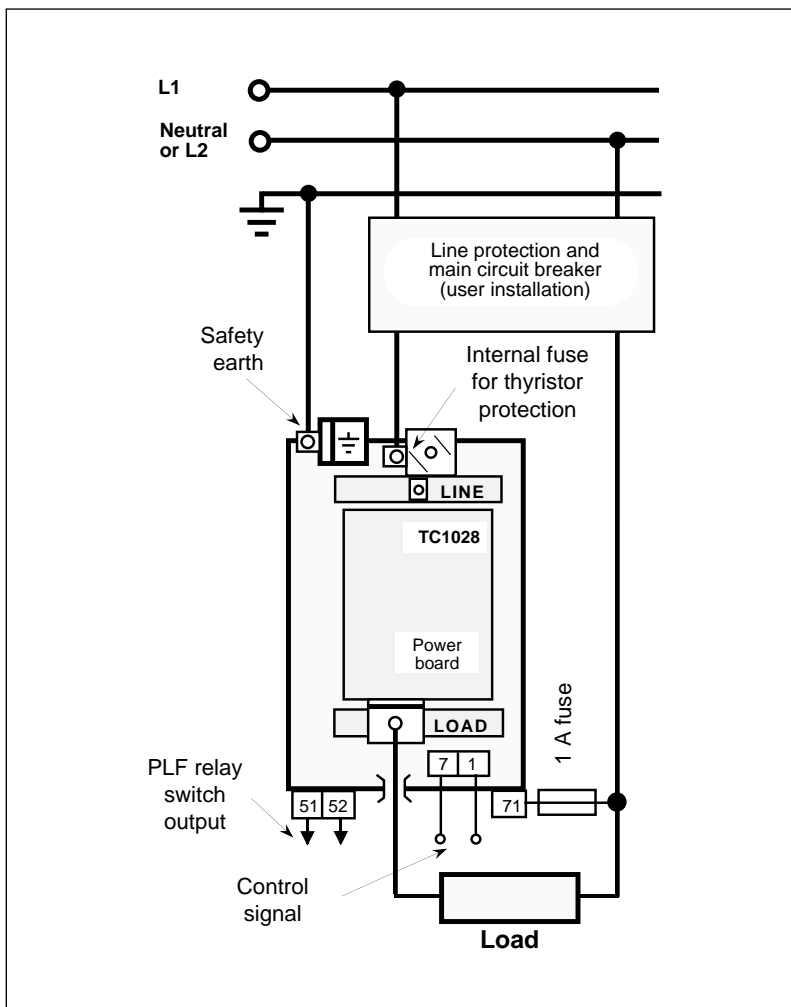

Figure 3-14 TC1028 thyristor unit configuration with a single-phase load

THREE-PHASE LOAD WIRING DIAGRAMS

Although the **TC1028** series thyristor units are single-phase units, they can be used to control three-phase loads.

In **three-phase operation**, the power and reference voltage configuration is determined by the load configuration.

The most economical three-phase application is to use the **TC1028** thyristor unit as a "**Master**", with **TC1027** series solid state contactors operating as "**Slaves**".

The "**Slave firing O/P**" logic signal output is provided on the **TC1028** control terminal block.

The auxiliary power supply configuration for **TC1027** solid state contactors is described in the "**TC1027 Series User Manual**", Part No. **HA 174762**.

The **TC1027** solid state contactor inputs must be configured for a **10 V** logic signal and connected in parallel.

Important !

In "**Master - Slave**" three-phase operation, only the "**Burst firing**" thyristor firing modes (Single cycle, fast and slow cycle) without soft operation are possible.

Load in star with neutral

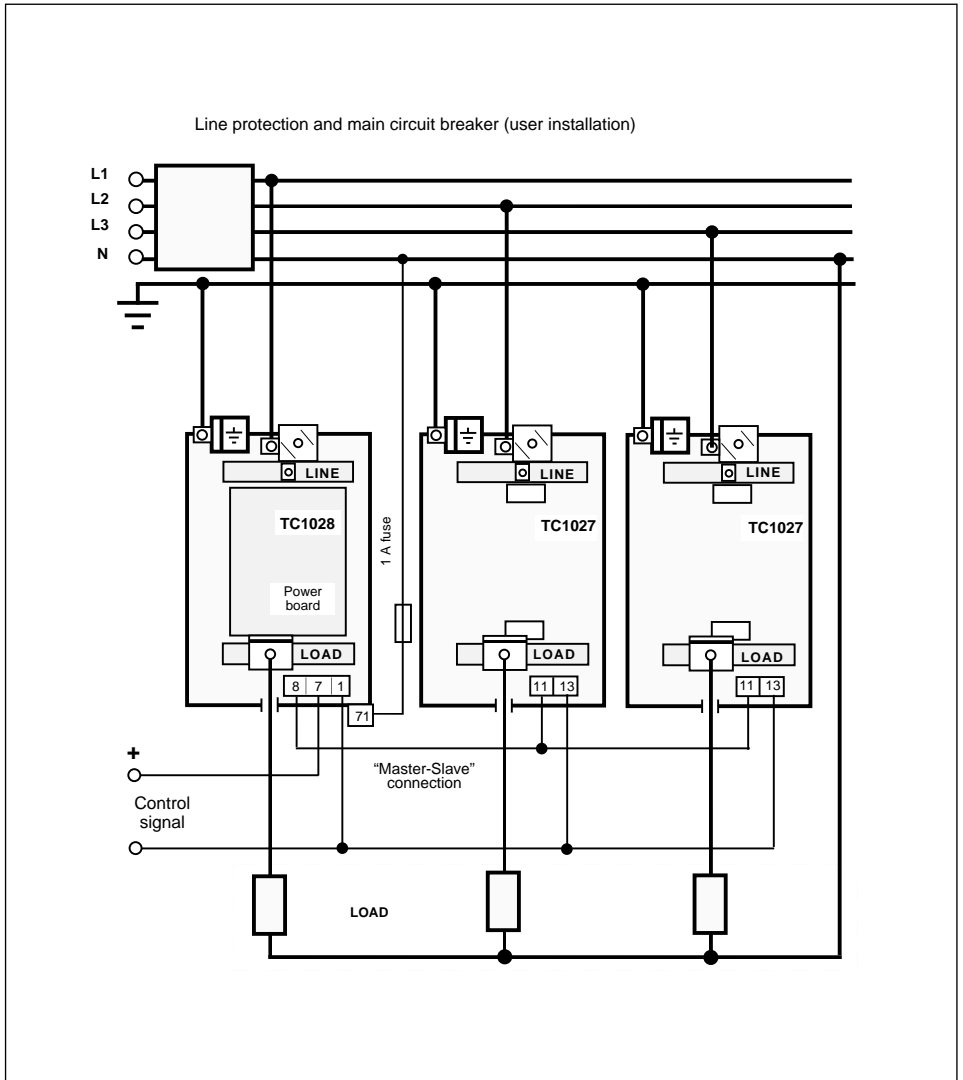

Figure 3-15 Configuration of a TC1028 thyristor unit ("Master") and two TC1027 solid state contactors ("Slaves"). Load in star with neutral. Low temperature coefficient resistive loads only

Load in open delta

For the open delta load configuration (6 wire configuration) 3 TC1028 series power thyristor units can be used with all the available firing modes.

The power configuration shown in the figure below must be observed.

Danger !



The thyristor units and reference voltage circuits are at the line to line voltage.

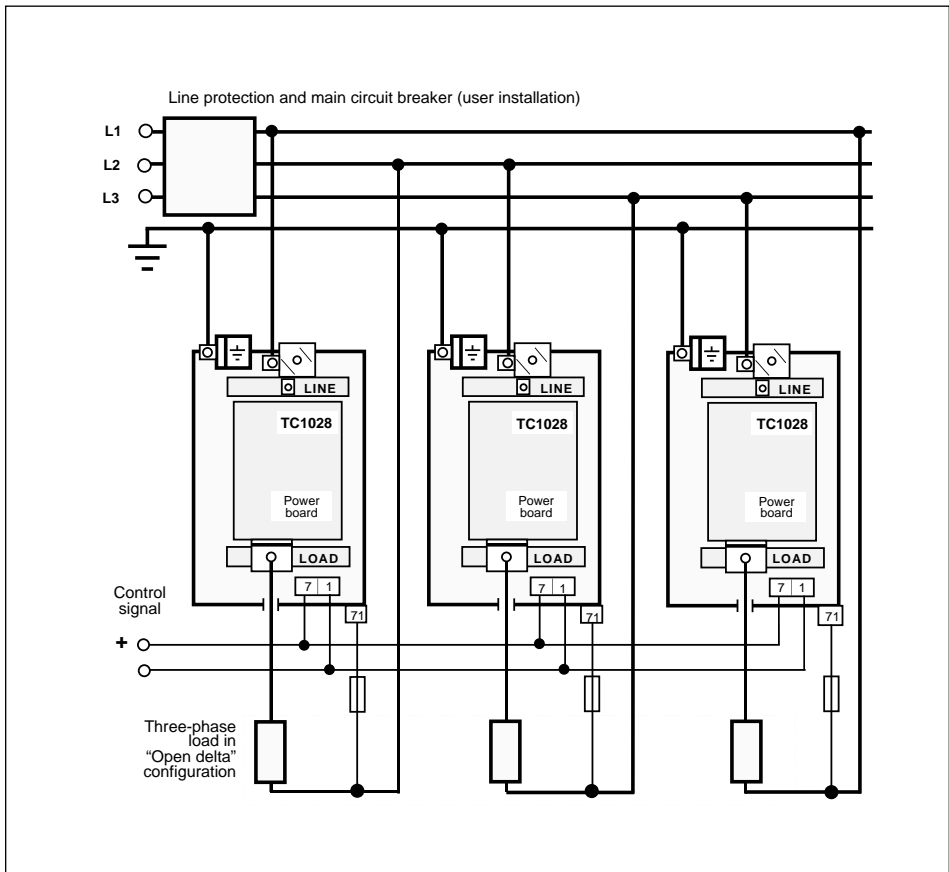

Figure 3-16 Wiring diagram of 3 TC1028 thyristor units in "Open delta"
Non used for the three-phase transformer primary circuits

Load in star without neutral or in closed delta (2 phase control)

For three-phase loads in a star without neutral or closed delta configuration (3 wire configuration), it is recommended to use the **2 phase control**.

A supply phase is direct (not controlled).

In the 2 controlled phases, a **TC1028** thyristor unit which operates as a "**Master**" and a **TC1027** solid state contactor operating as a "**Slave**" must be connected.

The "**SLAVE FIRING O/P**" control logic output (terminal **8**) is provided on the TC1028 driver board user terminal block.

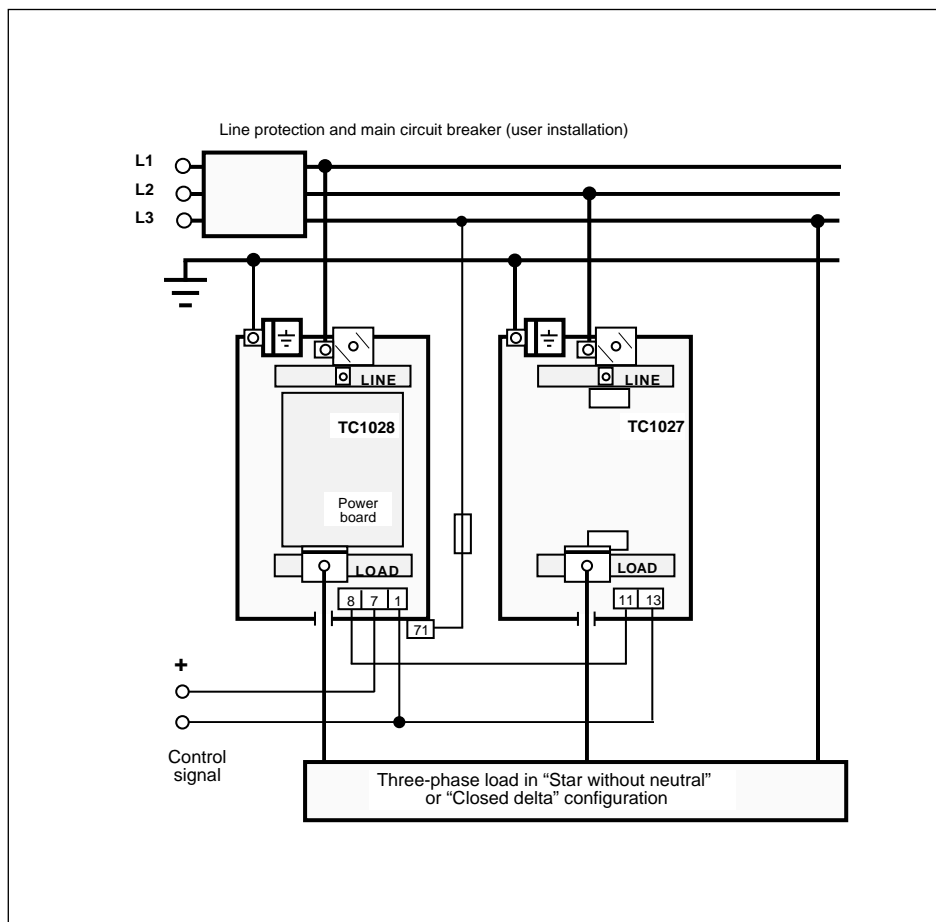

Figure 3-17 Configuration of thyristor unit and a solid state contactor in 2 phase control
Not used for the three-phase transformer primary circuits

PLF ALARM SIGNALLING

The partial load failure (**PLF**) alarm relay switch, which signals the active state of the alarm, is connected to the user terminal block under the unit, **on the left**.

The switch output terminals are marked **51** and **52** on the terminal block label.

The PLF alarm relay is **de-energised in alarm status**.

In the **standard** version, the relay switch available between terminals 51 and 52 is **open** in alarm status.

In the **IPF** option, the alarm relay switch is **closed** in alarm status.

The partial load failure detection alarm relay switch is protected against interference by an **RC** snubber on the driver board.

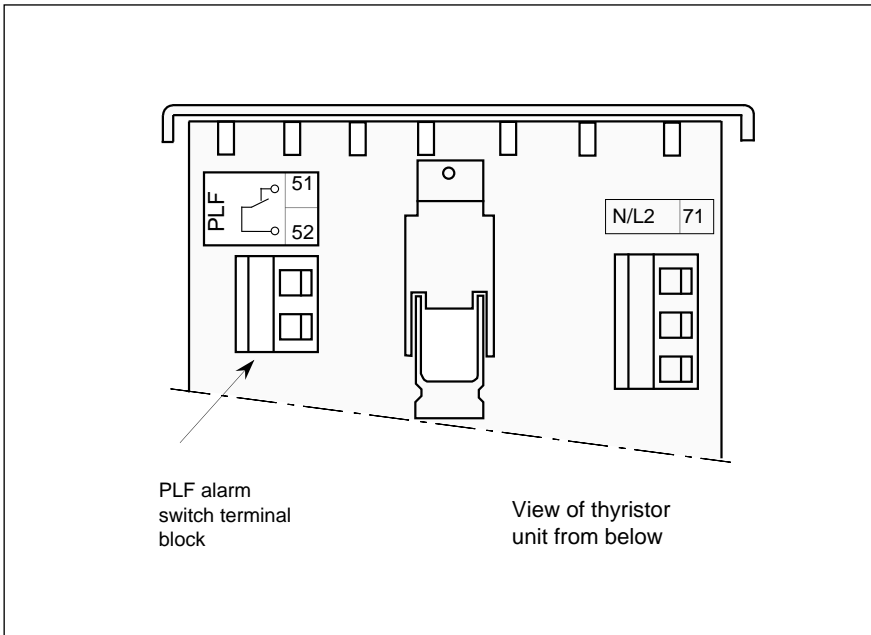

Figure 3-18 PLF alarm relay switch connection

Chapter 4

CONFIGURATION

Contents	page
Safety during configuration	4-2
Power board	4-3
Voltage selection	4-3
Driver board	4-4
Input signal	4-5
Control signal type	4-5
Input configuration	4-5
Thyristor firing mode	4-6
RMS current retransmission	4-7
Frequency	4-8

Chapter 4 CONFIGURATION

SAFETY DURING CONFIGURATION

The thyristor unit is configured in the factory using moveable **jumpers** and soldered **links**. The thyristor unit is **reconfigured** on site using **jumpers**.



Important !

The unit is supplied fully configured in accordance with the code on the identification label.

This chapter is included in order to

- **check** that the configuration is compatible with the application
- **modify**, if necessary, certain characteristics of the unit on-site.

Danger !



For safety reasons, the reconfiguration of the thyristor unit using jumpers must be performed with the unit **switched off** and by qualified personnel only.

Before starting the reconfiguration procedure, check that the thyristor unit is insulated and that an occasional power-up is impossible.

After the reconfiguration of the unit, correct the codes on the identification label to prevent any maintenance problems later.

POWER BOARD

Adaptation to the nominal supply voltage is performed on the power board.

Voltage selection

The nominal line to line voltage (specified on the order) is configured by the position of jumpers **JP1** to **JP6** and by the type of auxiliary power supply transformer. 3 types of transformer are used (see table 4-2). In the factory, the line voltage is **configured** according to the code on the thyristor unit identification label.

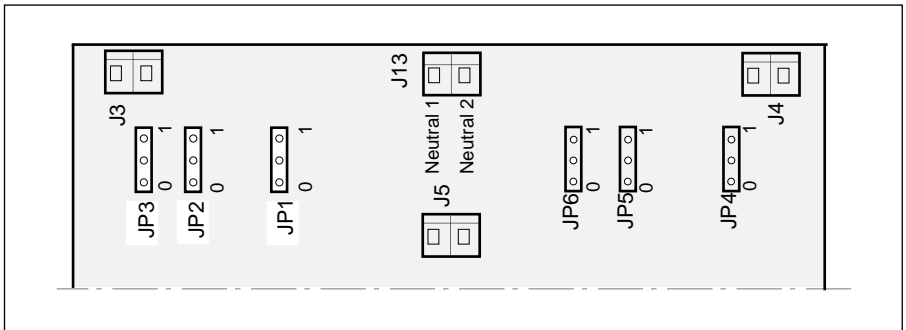

Figure 4-1 Location of jumpers on the power board

Line to line voltage	Position of jumpers			Transformer Part No.
	JP1 JP4	JP2 JP5	JP3 JP6	
100 V	0	0	1	CO 174 973
110 to 120 V	0	0	1	CO 174 544
127 V	0	0	1	CO 174 613
200 V	0	1	0	CO 174 973
220 V to 240 V	0	1	0	CO 174 544
277 V	0	1	0	CO 174 613
380 V to 415 V	1	0	0	CO 174 544
440 V	1	0	0	CO 174 973
480 V to 500 V	1	0	0	CO 174 613

Tableau 4-2 Voltage configuration

Attention !



The voltage given in the above table must be **less higher** or equal to the line to line voltage.

DRIVER BOARD

The driver board jumpers are used to configure the thyristor firing mode, the input signals, the RMS option and the frequency of the supply used.

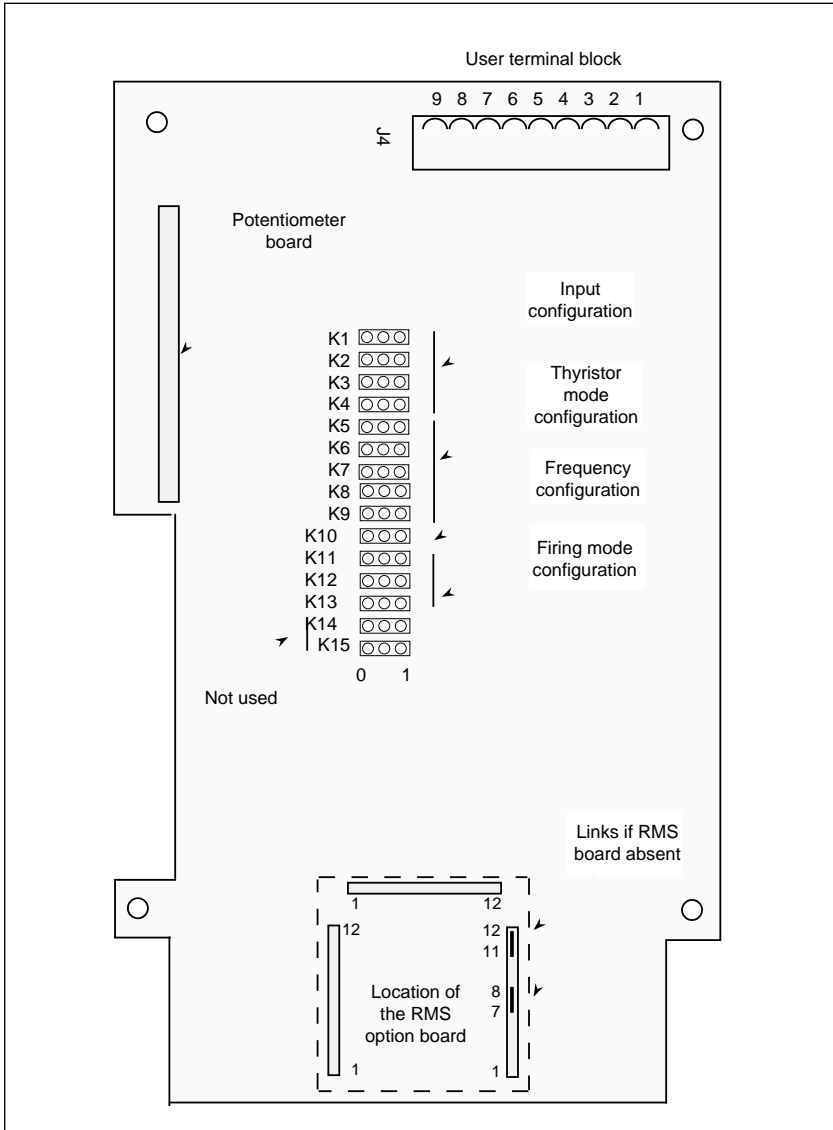

Figure 4-2 Location of configuration jumpers on the driver board

Input signal

Control signal type

The **TC1028** thyristor unit control signal parameters are given in table 4-2.

Input	Control signal		Input impedance
	Lower threshold (0 %)	Upper threshold (100 %)	
0 - 5 V	0.2 V	4.2 V	50 k Ω
1 - 5 V	1.16 V	4.36 V	
0 - 10 V	0.4 V	8.4 V	
2 - 10 V	3.3 V	8.7 V	
0 - 20 mA	0.8 mA	16.8 mA	250 Ω
4 - 20 mA	4.6 mA	17.4 mA	

Table 4-2 Control signal types and scales

Input configuration

The input signal can be configured with a choice of four voltage levels and two current levels. Jumpers **K5** to **K10** are used for this configuration.

Control	Input level	Position of jumpers			
		K1	K2	K3	K4
External	0-5 V	0	0	0	0
	1-5 V	1	0	0	0
	0-10 V	0	1	0	0
	2-10 V	1	1	1	0
	0-20 mA	0	0	0	1
	4-20 mA	1	0	0	1
Manual	0-5 V	0	0	0	0

Table 4-3 TC1028 thyristor unit input configuration

Thyristor firing mode

The firing modes available for the power thyristor units can be configured using **jumper K5** to **K9** and **K11** to **K13** installed on the driver board.

Thyristor firing mode	Position of jumpers							
	K5	K6	K7	K8	K9	K11	K12	K13
Firing angle variation	0	0	0	0	0	0	0	0
Single cycle	1	0	0	1	0	0	1	1
Fast cycle	1	1	0	1	0	0	1	1
Fast cycle with soft start	1	1	1	1	0	0	1	1
Fast cycle with soft start and end	1	1	1	0	0	0	1	1
Slow cycle	1	1	0	1	1	-	-	-
Slow cycle with soft start	1	1	1	1	1	-	-	-
Slow cycle with soft start and end	1	1	1	0	1	-	-	-

Table 4-4 Thyristor firing mode configuration

Note: (-) in table 4-4 indicates that the jumper position is insensitive.

RMS current retransmission

The retransmission of the RMS value of the load current is ensured by installing the **RMS option board** on the driver board (see figure 4-2).

This board is installed using **3** groups of pins labelled with the numbers **1** to **12**.

If the RMS option board is not installed (and therefore the current retransmission and the bargraph display are in instantaneous values), pins **11** and **12** and pins **7** and **8** must be short circuited by the jumpers supplied (see figure 4-2).

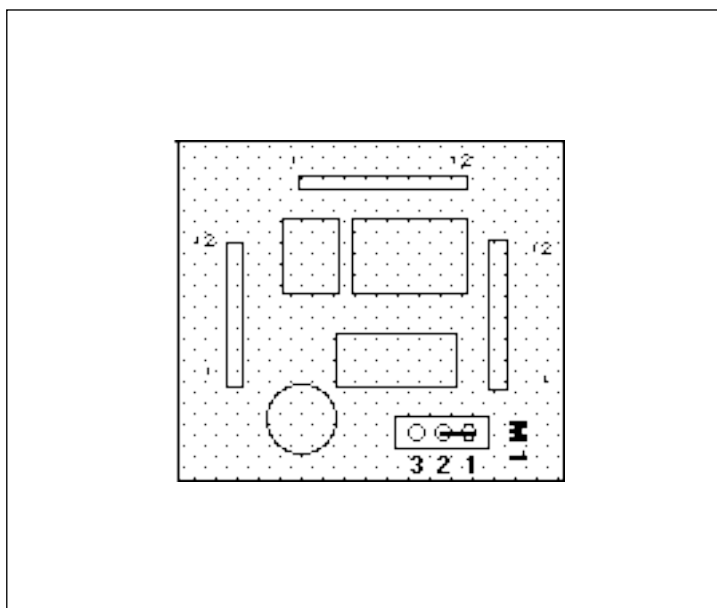

Figure 4-3 RMS option board

With the RMS option, the jumper **M1** on the RMS option board must be in position **1-2**, as shown in figure 4-3.

Frequency

In the standard version, the operating frequency of the TC1028 is **50 Hz**.

As an option (code **60 H**), the frequency is **60 Hz**.

The value of the frequency used is configured using jumper **K10** on the driver board.

Frequency	Position of jumper K10
50 Hz	1
60 Hz	0

Table 4-5 Frequency configuration of the supply used

:

Chapter 5

OPERATION

Contents	page
Thyristor firing modes	5-2
General	5-2
"Phase angle" mode	5-2
"Burst firing" mode	5-3
"Single cycle" mode	5-3
Modulation period	5-4
Soft start / end	5-5
Over-current elimination for the inductive load	5-6
Feedback	5-7
Feedback function	5-7
Supply voltage variation compensation	5-8
Selective trigger pulse blocking	5-9
Current limit	5-10
Linear current limit	5-10
Threshold current limit	5-11
Partial load failure detection	5-12
Retransmission	5-13
Retransmission signal	5-13
Load current image	5-13
Load voltage image	5-13
Bargraph indication	5-13
Enable / Inhibition	5-14
"Master-Slave" operation	5-14

Chapter 5 OPERATION

THYRISTOR FIRING MODES

General

The **TC1028** series power thyristor units possess the following thyristor firing modes:

- Phase angle
- Single cycle mode
- "Fast cycle" burst firing (modulation period at 50 % power: 0.6 s)
- "Slow cycle" burst firing (modulation period at 50 % power: 10 s)
- Fast cycle with soft start and end adjustable between 0 and 250 ms
- Slow cycle with soft start and end adjustable between 0 and 250 ms.

They can be reconfigured by the user as described in the "Configuration" chapter.

"Phase angle" mode

In "**Phase angle**" mode, the power transmitted to the load is controlled by firing the thyristors for a part of the supply voltage alternation (see figure 5-1).

The **firing angle** (Θ) varies in the same direction as the output power with the control system. The power emitted is not a linear function of the firing angle.

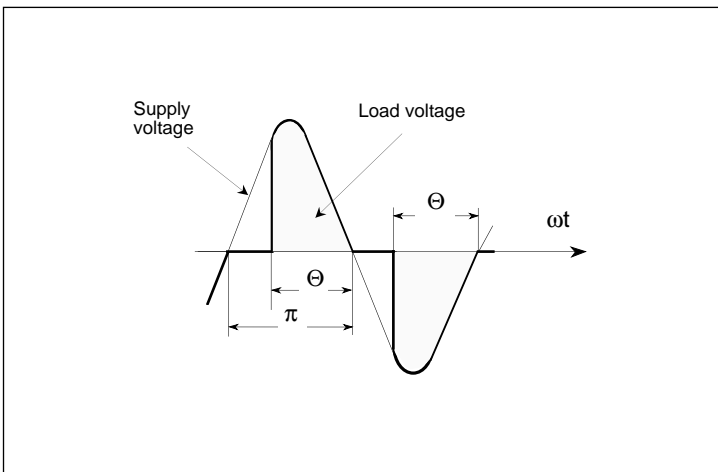

Figure 5-1 "Phase angle" firing mode

"Burst firing" mode

The "**Burst firing**" mode is a **proportional cycle** which consists of supplying a series of **complete** supply voltage **to the load**.

Thyristor firing and non-firing are synchronised with the supply and are performed **at zero voltage** for a resistive load.

This firing eliminates the steep fronts of the supply voltage applied to the load, **does not produce interference** on the supply and, in particular, prevents the generation of parasites.

In the "**Burst firing**" thyristor firing mode, the power supplied to the load depends on firing periods T_F and non-firing periods T_{NF} . The load power is proportional to the firing rate τ and is defined by the ratio of the thyristor firing period (T_F) and the modulation period ($T_M = T_F + T_{NF}$).

The firing rate (or cyclic ratio) is expressed by the following ratio:

$$\tau = \frac{T_F}{T_F + T_{NF}}$$

The load power can be expressed by:

$$P = \tau \cdot P_{MAX}$$

where P_{MAX} represents the load power during thyristor firing.

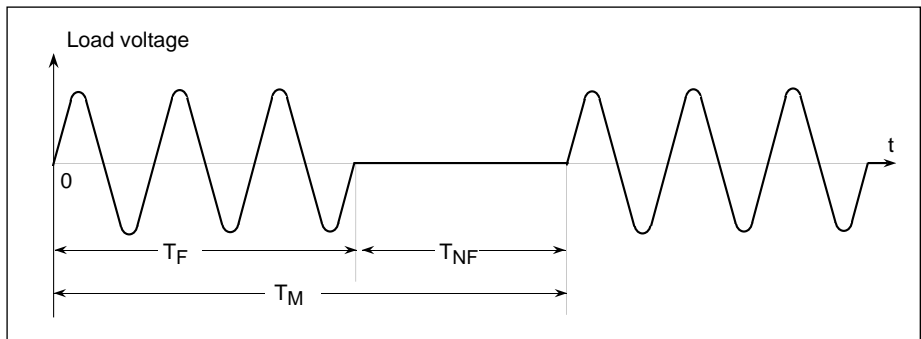

Figure 5-2 Periods of a Burst firing cycle

"Single cycle" mode

The "Burst firing" mode with a **single** firing or non-firing period is called the "**Single cycle**" mode.

Modulation period

The modulation period in "Burst firing" mode is **variable** according to the output power. Due to this type of feedback, the TC1028 unit possesses adjustment precision adapted to each specific setpoint zone:

- At **50 %** power, the typical value of the modulation period is:
0.6 s for the "Fast cycle"
10 s for the "Slow cycle".
- For a zone less than **50 %** of the maximum setpoint, the **firing** period is decreased and the modulation period is increased.
- For a power zone greater than **50 %**, the **non-firing** period is decreased with the increase in the modulation period.

For example, in the "Fast cycle":

- for 5 % power, $T_F = 250 \text{ ms}$, $T_M = 5 \text{ s}$
- for 90 % power, $T_F = 2.25 \text{ s}$, $T_M = 2.5 \text{ s}$.

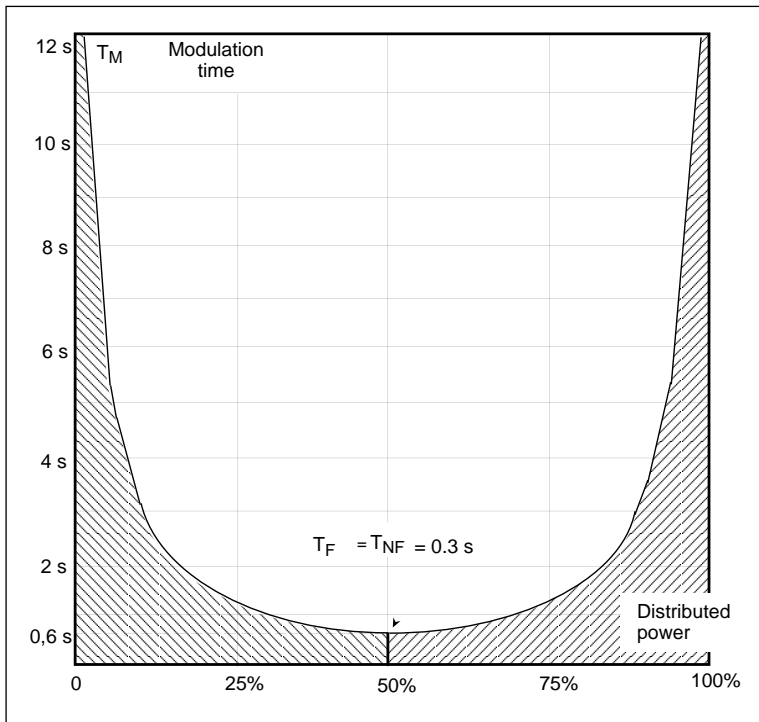

Figure 5-3 Modulation period as a function of power ("Fast cycle")

Soft start / end

Soft operation (start or start and end) can be configured in the "Slow cycle" and "Fast cycle" Burst firing modes.

The soft start duration (T_{ss}) is the time taken for the thyristor unit output power to change from 0% to 100% by varying the thyristor firing angle from 0 to **full firing**.

The soft end duration (T_{se}) is the time take for the thyristor unit output power to **change** from 100% to 0% by varying the thyristor firing angle from **full firing** to 0.

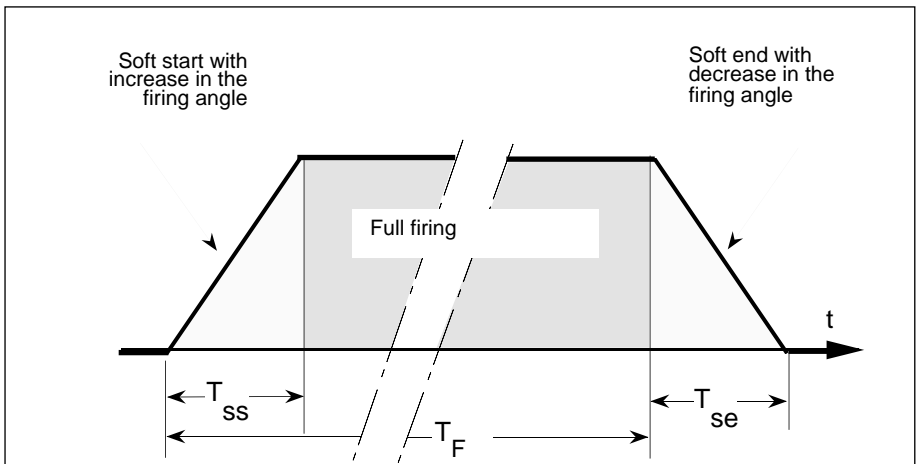

Figure 5-4 Soft start and end in Burst firing mode

The soft end time (T_{se}) is not included in the firing period (T_F), but all the power sent to the load is taken into account in the feedback.

After the soft start by thyristor firing angle variation, the thyristor unit remains in **full firing** during the firing time.

Note :

For soft starts of loads with very high resistance variations (e.g.: Kanthal Super), use the **Special 603**, which has an increased start time.

Over-current elimination for the inductive load

The "Fast cycle" and "Slow cycle" Burst firing modes, composed of whole periods, start at zero voltage for purely resistive loads.

For inductive loads, firing at zero voltage generates transient operation which could, in certain cases, induce a saturation of the magnetic circuit, the appearance of over-currents (figure 5-5,a) and a blow-out of the high speed fuse (thyristor protection).

To prevent this saturation, the first firing of the thyristors for inductive loads can be **delayed** with reference to the corresponding zero voltage (figure 5-5,b).

The optimum **delay angle** (ϕ) must be adjusted with the "**Delay/Retard**" potentiometer on the front fascia (see adjustment) as a function of the load (max. delay **90°**).

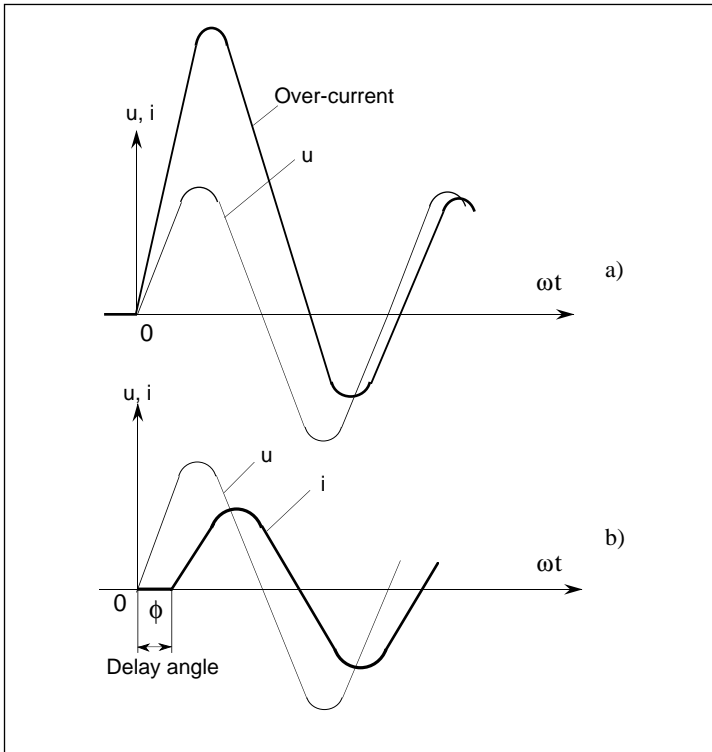

Figure 5-5 Inductive load switching at zero voltage (a) and with delay angle (b)
(ramp for transformer primary circuits)

FEEDBACK

Feedback function

The TC1028 series power thyristor units contain an internal feedback loop. The thyristor unit output power is linear between **0** and **100 %** of the maximum voltage for the input signal varies between **4** and **84 %** of the maximum scale.

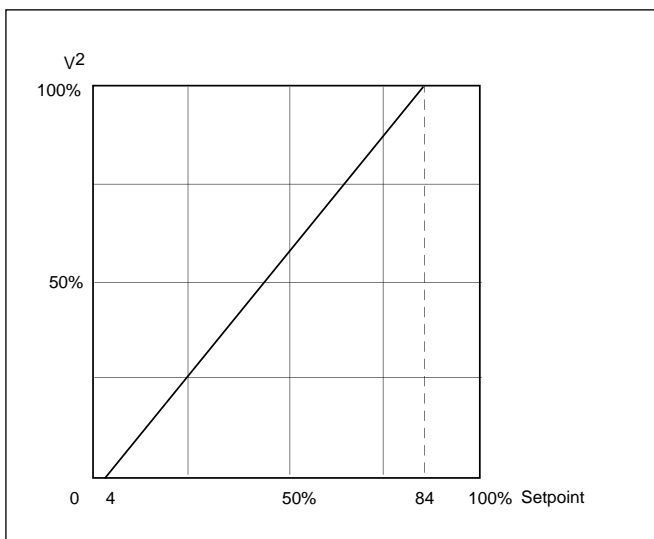

Figure 5-6 Controlled parameter as a function of the setpoint

The **squared RMS load voltage** represents the power dissipated in a purely resistive load, the value of which is constant with the temperature variation. The accuracy of the power feedback is guaranteed to be within $\pm 2 \%$ of the maximum voltage.

The feedback system automatically selects the higher value of two parameters (V^2 ou I^2).

For loads with low resistance variation as a function of temperature (nickel, chromium, aluminium, Inconel, iron alloys, etc.), the feedback in V^2 is sufficient.

Feedback with automatic transfer between the two controlled values is very important for loads with high resistance variation as a function of the temperature (molybdenum, molybdenum bisilicide, tungsten, platinum, etc.).

For this type of load, the operation is as follows:

- I^2 feedback at start when cold
- automatic feedback type change to V^2 when hot, which allows optimum control and feedback at all temperatures.

Supply voltage variation compensation

The supply variation compensation acts in the range: + **10 %** to - **15 %** of the thyristor unit nominal voltage. This voltage is self-supplied on the power and reference phases.

Without a supply voltage variation compensation, a **10 %** decrease or increase in the supply voltage would induce a **20 %** decrease or increase in the power supplied to the thyristor unit load.

For a constant resistive load, the feedback with supply variation compensation is used to maintain the output power constant in spite of the supply voltage variations

Supply voltage variation range (%)	Setpoint (%)	Power supplied (%)	
		With compensation	Without compensation
0 to +10	100	100	100 to 121
-5 to +10	90	90	81 to 109
-10 to +10	80	80	65 to 97
-15 to +10	70	70	50 to 85

Table 5-1 Feedback with supply variation compensation

Table 5-1 shows the stabilisation of the output power on a constant resistance as a function of the supply variations.

If the voltage falls below **80 %** of its nominal value, the thyristor unit is inhibited.

A compensation circuit simultaneously adjusts the thyristor firing time as a function of the supply variations. This compensation prevents power fluctuations and the intervention of the feedback loop, enabling a quicker response.

Selective trigger pulse locking

The **TC1028** thyristor unit thyristors are fired by a trigger **pulse train** of a maximal duration of **5 ms**.

In most single-phase applications, it is possible to send trigger pulses every **10 ms** so that the thyristors are polarised in direct mode (positive anode in relation to the cathode) or in inverse mode (negative anode).

Each thyristor is only fired when its voltage is positive, when it is negative, the anti-parallel thyristor is fired.

In certain applications, the trigger pulses on the polarised thyristor in inverse mode can lead to operating problems: firing instability, fuse blow-out.

It is therefore necessary to **eliminate** the trigger pulses when the thyristor is polarised in **inverse** mode.

This function is performed by the **selective trigger pulse blocking** circuit available for **TC1028** thyristor units.

This selective trigger pulse blocking is essential for configuration in which multiple thyristor units are distributed between the phases of a three-phase supply and have an electrical configuration which could induce a voltage **phase shift**.

For example:

- control of heating electrodes (in transformer secondary coil) immersed in the same molten glass
- load in star with neutral, with the central point of the star connected to the supply neutral by a wire of a non-negligible resistance with reference to that of the load.

CURRENT LIMIT

The TC1028 thyristor units possess two types of current limit with the load current measurement:

- a **linear** current limit and
- a **threshold** current limit.

These two limits are **independent**.

Linear current limit

This function limits the squared RMS load current I^2 .

In current limit, the correspondence between the load current and the input signal can be adjusted using the potentiometer labelled "**I limit / Limit.I**" on the front fascia.

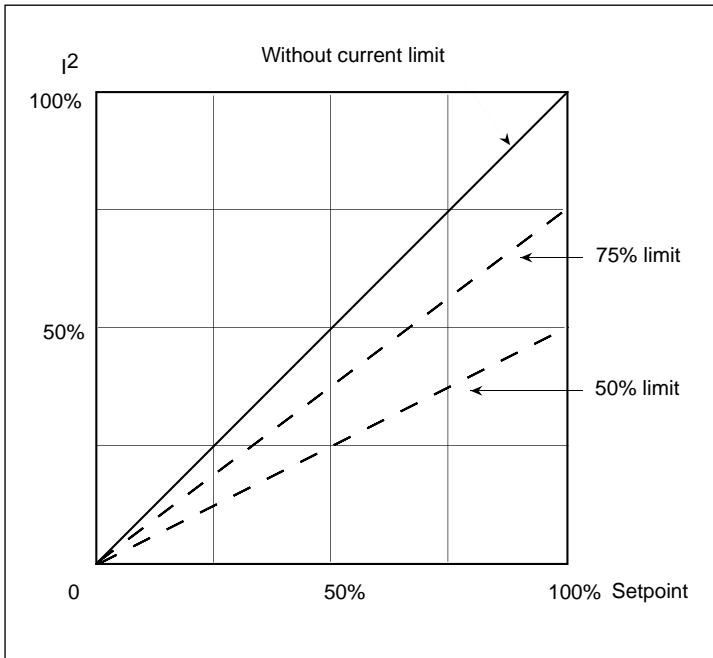

Figure 5-7 Linear current limit

The power feedback in V^2 and the current limit in I^2 provide the best control in all the feedback zones.

Threshold current limit

This type of limit is used to limit the load current to a **desired value** independently of the input signal and the linear current limit.

The "I Limit I/P" input (terminal **5** of the control terminal block) can be controlled:

- by an external adjustment **potentiometer**
- by a **0-10 V** external dc voltage.

When the threshold limit (by potentiometer or by voltage) is not used, terminal **5** of the driver board user terminal block must be connected **directly** to the **+10 V** user voltage (terminal **2**). Otherwise, the threshold current limit is at zero and the thyristor unit cannot output.

In this case, the current is limited to **110%** of the thyristor unit nominal current.

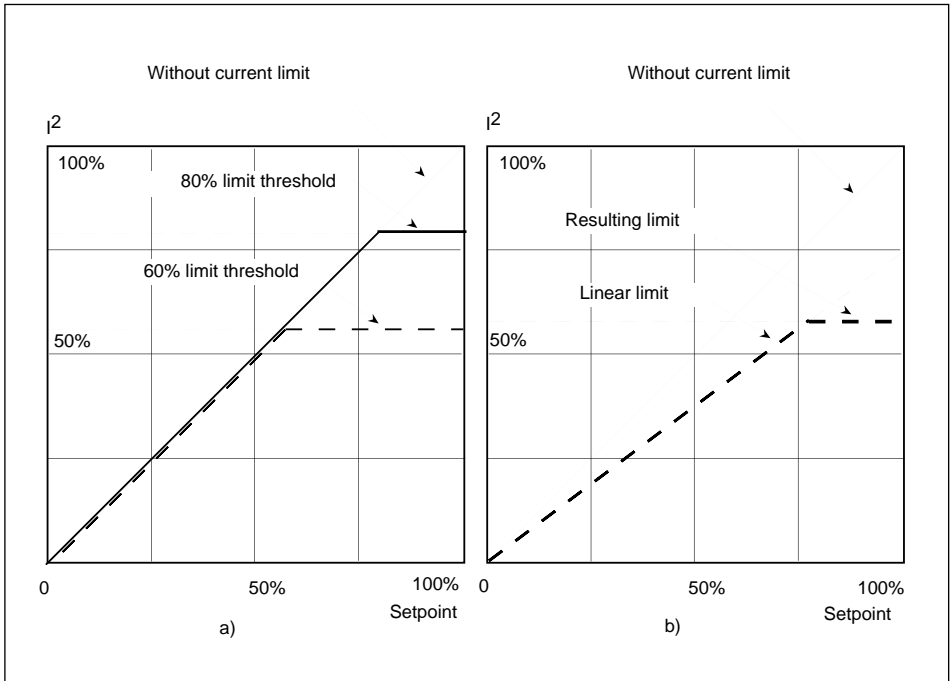

Figure 5-8 Threshold current limit (a) and use of 2 types of limit simultaneously (b)

PARTIAL LOAD FAILURE DETECTION

The "partial load failure" (**PLF**) alarm detects an increase in the load impedance due to the failure of heating elements, for example.

The sensitivity of the PLF circuit is used to detect the increase in the load impedance to **20 %**, which detects the failure of one element out of **5** identical elements mounted in parallel.

On the **TC1028** thyristor unit, the alarm is indicated:

- by an **indicator light** mounted on the front panel and labelled "**Load Fail**" (lit when a partial load failure is detected)
- by the alarm relay **switch** (switch output is available on terminals **51** and **52** on the user terminal block at the bottom left-hand corner of the thyristor unit).

The alarm relay is **exited** outside alarm status when the thyristor unit power is on.

The alarm switch (cut-out capacity **0.25 A** at **250 Vac** or **30 Vdc**) in the standard version is **open in alarm status** or in the event of a **supply failure**.

As an option (code **IPF**), this switch is **closed** in alarm status.

The PLF alarm relay switch output is suitable for the control of an alarm unit

The PLF alarm relay is acknowledged either by switching off the thyristor unit or by resetting to the nominal current.

RETRANSMISSION

The **TC1028** thyristor units possess retransmission of load current and voltage images in the form of a signal (available on the control terminal block) and a bargraph current display on the front fascia.

Retransmission signal

Load current image

The "Load current image" is available on the control terminal block between terminals **4** ("**I Load O/P**") and **1** ("**0V**").

It can be used for tests or for an external measurement.

In the **standard version**, the double alternation rectified output signal is directly proportional to the instantaneous load current (**4.4 V** mean for the thyristor unit nominal current in full firing).

As an **option (RMS option board)**, the retransmission signal (**0-10 V**) is proportional to the **RMS** load current.

The value of this signal is **10 V** for the thyristor unit nominal current.

Load voltage image

The "Load voltage image" output is available between terminals **3** ("**V Load O/P**") and **1** ("**0V**") on the driver board user terminal block.

In the **standard** version and in the **RMS option**, this is a double alternation rectified signal (**4.1 V** mean) representative of the load voltage in full firing, produced using the **auxiliary supply**.

Bargraph indication

The front fascia bargraph has **10** segments and displays the load current with an accuracy of within **10 %** of the thyristor unit **nominal** current:

- in the standard version: the instantaneous load current
- in the RMS option: the RMS value of the load current (in phase angle, single cycle and fast cycle firing modes with or without soft start or end).

ENABLE / INHIBITION

The **TC1028** thyristor units possess an **active operation enable** function requiring the application of a voltage on a control terminal block.

The absence of the enable voltage induces the inhibition of thyristor unit operation meaning that the thyristors cannot fire irrespective of the input signal.

The enable / inhibition input is available between terminal **9 ("Enables I/P")** and terminal **1 (0 V)** of the driver board.

The enable is effective when a **+10 V** dc voltage is applied to terminal **9 (4 V minimum, 32 V maximum)** with reference to terminal **1** (see figure 3-7 on page 3-12).

To enable the thyristor unit, the connection (using a normally closed switch) of the "**Enables I/P**" terminal to the "User **+10 V**" voltage output (terminal **2**) can be used.

Opening this switch inhibits the thyristor unit.

"MASTER-SLAVE" OPERATION

The logic signal (**10 Vdc, 10 mA**) is available between terminals **8 ("Slave Firing O/P")** and **1 (0 V)** when the **TC1028** thyristor unit is in slow cycle, fast cycle or single cycle firing mode.

The "Slave Firing O/P" is used to **control** solid state contactors.

Using this logic signal output, it is possible to perform a "Master-Slave" operation configuration of a **TC1028** thyristor unit ("Master") which controls one or more **TC1027** series solid state contactors ("Slaves") for the economical control of single-phase or three-phase loads (see "Cabling" chapter).

Chapter 6

COMMISSIONING PROCEDURE

Contents	Page
Commissioning procedure safety	6-2
Checking the characteristics	6-3
Load current	6-3
Supply voltage	6-3
Reference voltage	6-4
Input signals	6-4
Partial load failure detection	6-4
Diagnostic unit	6-5
Preliminary adjustments	6-8
Resistive load with low resistance variations	6-10
Resistive load with high resistance variations	6-10
Inductive load	6-11
Partial load failure detection adjustment	6-12
Current limit adjustment	6-13
Linear limit	6-13
Threshold limit	6-14
Checks in the event of abnormal operation	6-15

Chapter 6 COMMISSIONING PROCEDURE

Read this chapter carefully before commissioning the thyristor unit

COMMISSIONING PROCEDURE SAFETY



Danger !

- Eurotherm cannot be held responsible for any damage to persons or property or for any financial loss or costs resulting from the incorrect use of the product or the failure to observe the instructions contained in this manual.
 - It is therefore the user's responsibility to ensure that all the nominal values of the power unit are compatible with the conditions of use and installation before commissioning the unit.
 - Dangerous live parts may be accessible when the front door is open. Only personnel qualified and authorised to work in industrial low voltage electrical environments can access inside the unit.
 - Access to internal components of the thyristor unit is prohibited to users who are not authorised to work in industrial low voltage electrical environments.
 - The temperature of the heatsink may exceed 100°C. Avoid all contact, even occasional, with the heatsink when the thyristor unit is in operation. The heatsink remains hot approximately 15 min after the unit has been switched off.
-

CHECKING THE CHARACTERISTICS



Attention !

Before connecting the unit to an electrical supply, make sure that the **identification code** of the thyristor unit corresponds to the coding specified in the **order** and that the characteristics of the thyristor unit are **compatible with the installation**.

Load current

The maximum load current must be less than or equal to the value of the nominal current of the thyristor unit taking the load and supply variations into account.

In three-phase operation, if the **3** identical loads are configured in **closed delta**, the line current of the thyristor unit (both "Master" and "Slave") is **$\sqrt{3}$ times as high** as the current of each arm of the load.

Supply voltage

The nominal value of the thyristor unit voltage must be greater than or equal to the voltage of the supply used.

In three-phase operation, the nominal voltage of the thyristor unit must be greater than or equal to the **line to line** voltage.



Danger !

Never use a thyristor unit with a supply **voltage greater** than the thyristor unit nominal voltage specified in the coding.

If the line voltage is less than **80%** of the nominal voltage, the thyristor unit is inhibited (thyristor control removed).

The unit is re-enabled automatically if the voltage returns to a value greater than or equal to **80 %** of the nominal value.



Attention !

Given the inhibition at 80 % of the nominal voltage, the nominal voltage of the thyristor unit must be as close as possible to the nominal voltage of the supply used.

Reference voltage

The reference voltage of the control electronics must correspond to the power voltage and is adapted by the position of the jumpers and by the selection of the transformers on the power board.

The transformers for the power supply to the electronics are selected in the factory, according to the order code (see "Configuration" chapter, page 4-3).

Input signals

The jumper configuration on the driver board must be compatible with the levels chosen for the signals used for control (see page 4-5).

Partial load failure detection

The voltage used for the PLF detection circuit is that of the reference phase/neutral.

Therefore, this voltage must correspond to the power voltage.



Attention !

The PLF alarm switch must be connected in the circuit with a voltage which must never exceed 230 V (single-phase or three-phase 230 V supply).

DIAGNOSTIC UNIT

For easier commission and adjustment operations and for the thyristor unit state diagnostics, it is advisable to use the **EUROTHERM type 260** diagnostic unit.

The **20-way switch** of the diagnostic unit is used to display the values of the thyristor unit and feedback parameters. The unit displays two decimal places in order to permit the precise indication of the selected values.

The diagnostic unit possesses a flat cable which is plugged into the 20-pin connector (diagnostic connector) provided on the front fascia of the thyristor unit.

The signals from the diagnostic connector may also be viewed using an oscilloscope.

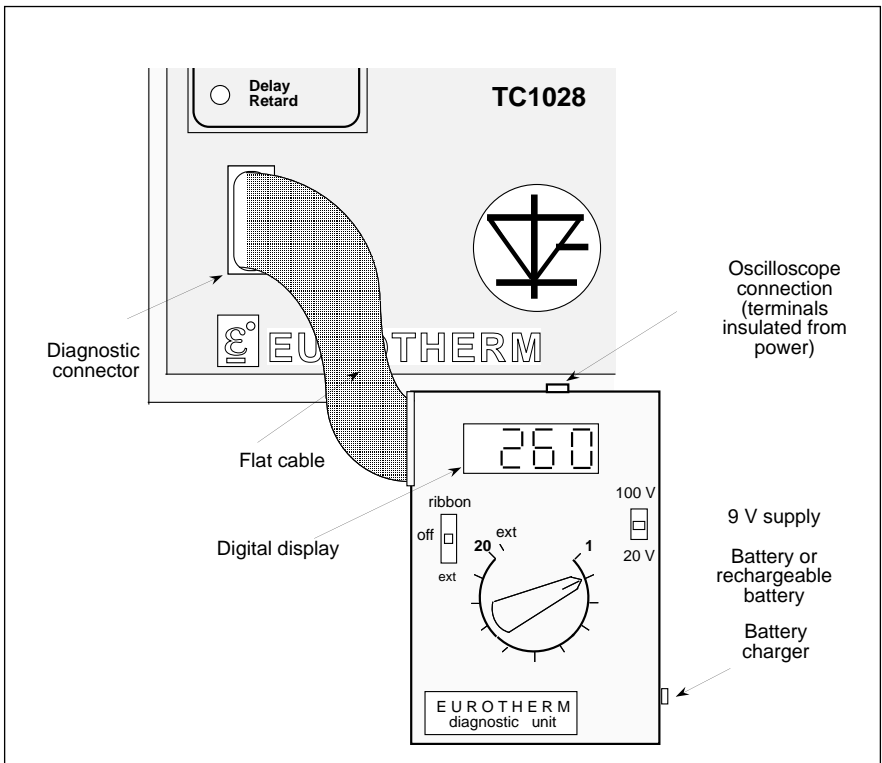

Figure 6-1 Connection of the EURO THERM type 260 diagnostic unit and the thyristor unit

The following table gives the description of each position of the diagnostic unit and the typical values of the signals measured (**mean dc values**).

Position	Description	0 % of setpoint $\Theta = 0^\circ$	50 % of setpoint $\Theta = 90^\circ$	100 % of setpoint $\Theta = 180^\circ$
1	Current image (nominal load)	0 V	2.2 V	4.4 V
2	Manual input (if used)	0 V	2.5 V	5 V
3	PLF output (not in alarm) In alarm status	- 12.6 V + 13.5 V		
4	External setpoint Example: 0-10 V	0 V	5 V	10 V
5	Threshold limit (max)	approx. 10 V		
6	Current image for PLF	0 V	- 2.5 V	- 4.6 V
7	Load voltage image	0 V	2.05 V	4.3 V
8	Amplified setpoint	0 V	- 2.5 V	- 5 V
9	"Slave Firing O/P" output	not used		
10	Firing demand	0 V mean 1V peak	8.4 V	12.7 V
11	"+10V" reference	10 V \pm 0.1 V		
12	Rectified double alternation -24 V	- 20 V		
13	Pulse output	20 V without pulses	20 V pulses	20 V pulses
14	"-15 V" supply	- 15 V \pm 150mV		
15	Oscillator input	0 V	1.2 V 6.4 V peak 90° pulses	1.2 V 6.4 V peak 90° pulses
16	"+ 15 V" supply	+ 15 V \pm 150mV		
17	"0' voltage crossing pulse	-10.5 V \pm 12V peak 0.5ms		
18	0 V	0 V		
19	Saw-tooth generator	3.6V 8.4V peak 10ms		
20	Enable	<- 10 V		

Table 6-1 Description of the positions of the EUROTHERM type 260 diagnostic unit
Thyristor firing angle variation (Θ).

Position	Description	0 % of setpoint	50 % of setpoint	100 % of setpoint
1	Current image (nominal load)	0 V	Modulation 0 - 4.4 V	4.4 V
2	Manual input (if used)	0 V	2.5 V	5 V
3	PLF output (not in alarm) In alarm status		- 12.6 V + 13.5 V	
4	External setpoint Example: 0-5 V	0 V	2.5 V	5 V
5	Threshold limit (max)		approx. 10 V	
6	Current image for PLF	0 V	Modulation 0 - (-4.6 V)	- 4.6 V
7	Load voltage image	0 V	Modulation 0 - (-4.1 V)	4.3 V
8	Amplified setpoint	0 V	-2.5 V	- 5 V
9	"Slave Firing O/P" output	0 V	Modulation 0 - 13.5 V	10.2 V (0-13.5 V)
10	Power demand	0 V mean 1V peak	6.25 V 12.5 V peak	12.5 V
11	"+10V" reference		10 V \pm 0.1 V	
12	Rectified double alternation -24 V		- 20 V	
13	Pulse output	No pulses	26 V pulses	26 V pulses
14	"-15 V" supply		- 15 V \pm 150mV	
15	Oscillator input	0 V	6.4 V peak	1.2 V 6.4 V peak
16	"+15 V" supply		+ 15 V \pm 150mV	
17	"0" voltage crossing pulse		-10.5 V \pm 12.5V peak 0.5ms	
18	0 V		0 V	
19	Saw-tooth generator		3.6V 8V peak 10ms	
20	Enable		< 10 V	

Table 6-2 Description of the positions of the EURO THERM type 260 diagnostic unit
Fast cycle and Single cycle

PRELIMINARY ADJUSTMENTS

The preliminary adjustment is used to adapt the first thyristor firings to the type of load used.

- For resistive loads **with low resistance variations**, firing at zero voltage does not generate steep voltage fronts, thus minimising the electromagnetic interference produced.
- For resistive loads **with high resistance variations**, use the "Burst firing" modes with the soft start, which reduces the current requirement when the load is cold with a low resistance.
- For **inductive** loads, the first firing with a delay eliminates the transient over-current (see "Operation" chapter).
This delay can be adjusted between **0** and **90°** and only acts on the first alternation.

The preliminary adjustment is made using the potentiometer labelled "**Delay/Retard**" on the front fascia. The effect of this adjustment potentiometer depends on the thyristor firing mode.

Thyristor firing mode	Effect of "Delay/Retard" potentiometer
Phase angle	No effect
Single cycle Slow cycle Fast cycle	Delay of first firing of thyristors at the start of each firing cycle
Burst firing with soft start	Soft start duration in thyristor firing angle variation
Burst firing with soft start and end	Soft start and end duration in thyristor firing angle variation

Table 6-3 Effect of the "Delay" potentiometer on the front fascia

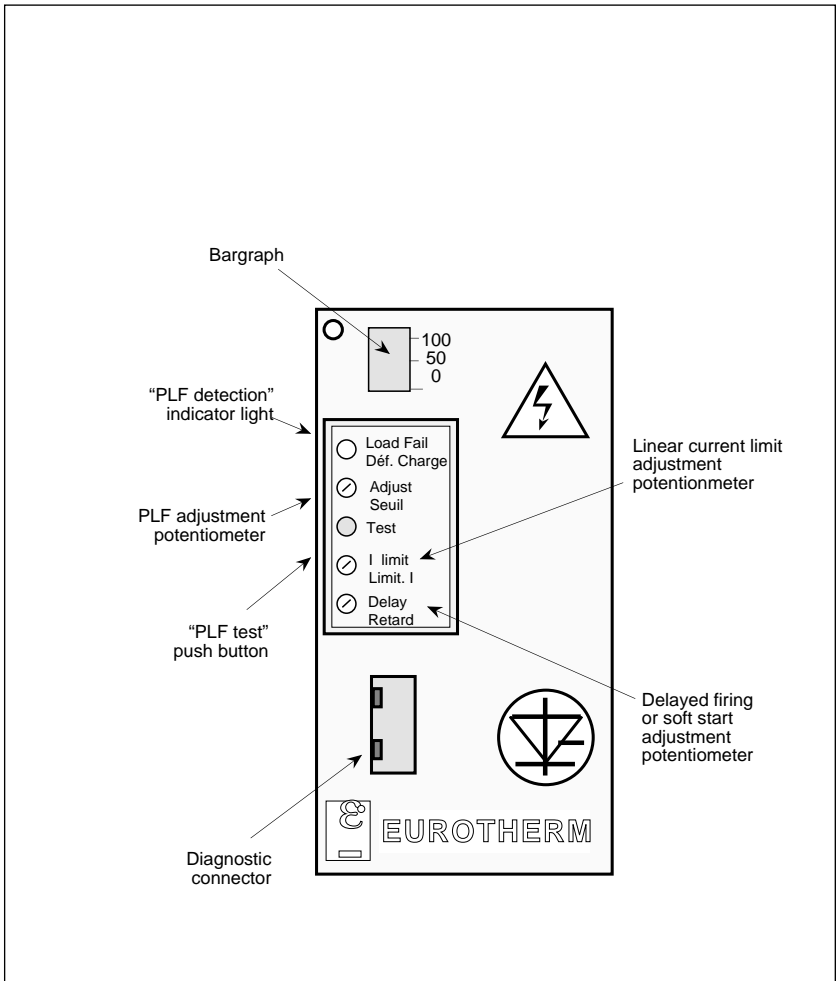

Figure 6-2 Front fascia of the TC1028 thyristor unit

Resistive load with low resistance variations

For loads with low resistance variations as a function of temperature, the adjustment must guarantee thyristor firing at zero voltage (in burst mode).

- Turn the "**Delay / Retard**" potentiometer on the front fascia completely anti-clockwise (delay angle = 0).
- Switch on the thyristor unit.
- On the external input (terminal **17** of the control terminal block), apply a signal corresponding to **0%** of the control signal.

Using an RMS ammeter, check that the load current does not pass.

- On the external input ("**Auto. Input**") terminal 7 or manual input ("**Manual Input**") terminal 6, apply a signal corresponding to **100%** of the control signal.

Using an RMS ammeter, check that the current is equal to the nominal load current.

Resistive load with high resistance variations

For loads with high temperature coefficients, use the Phase angle mode or the soft start in thyristor firing angle variation.

The start (or start and end) time is adjusted using the "**Delay / Retard**" potentiometer on the front fascia, for the following thyristor firing modes:

- slow cycle with soft start (code SSC)
- fast cycle with soft start (code SFC)
- slow cycle with soft start and end (code SDS)
- fast cycle with soft start and end (code SDF).

The soft start (or start and end) ramp can be adjusted between **0** and **250 ms**.

The maximum ramp is obtained with the "**Delay/Retard**" potentiometer turned completely **clockwise**.

In the case of the control of a load with very high resistance variations as a function of the temperature (Kanthal Super, for example), use (on request) **the Special 603** (not for Phase angle mode).

Inductive load (not saturable)

When the load has an inductive component (primary transformer circuit or inducer), firing at zero voltage generates transient operation which is conveyed by an over-current at the start of each burst (see "Operation" chapter) and, in certain cases, the blowing of thyristor protection high speed fuses.

To prevent these over-currents, at the start of each burst, **for the not saturable inductive load** the first thyristor firing must be **delayed** in relation to the corresponding zero voltage.

The **optimum** delay angle (90° max) must be **adjusted** according to the **load used** by the "**Delay / Retard**" thyristor firing delay angle adjustment potentiometer.

For this adjustment:

- Apply a control signal corresponding to approximately 20% of the maximum setpoint. Make sure that the "**Delay/Retard**" potentiometer is turned completely clockwise.
- Turn the "**Delay/Retard**" potentiometer anti-clockwise, in order to reduce the peak current (displayed by bargraph without RMS option) or the over-current (visible on the screen of an oscilloscope) as much as possible at the start of each burst.

In the factory, the "**Delay/Retard**" potentiometer is adjusted as shown in table 6-4.

Thyristor firing mode	Position of "Delay/Retard" potentiometer
Fast cycle Slow cycle Single cycle	Completely anti-clockwise (Minimum delay)
Soft start Soft start and end	Completely clockwise (Maximum ramp)
Phase angle	No effect. Position insensitive

Table 6-4 Adjustments in factory

In the case of the control of a saturable inductive load (primary transformer circuit with a load with low resistance variations as a function of the temperature, for example), use (on request) **the Special 669** (not current limit, not PLF).

PARTIAL LOAD FAILURE DETECTION ADJUSTMENT

The partial load failure (PLF) detection is adjusted using the potentiometer labelled "**Adjust/Seuil**" on the front fascia (see figure 6-2).

The purpose of this adjustment is to adapt the PLF detection with the maximum sensitivity to the real thyristor unit load.

To guarantee correct operation of the PLF detection circuit, the load current must not be less than **10 %** of the thyristor unit nominal current (in the case of use of a bulb as a load for a thyristor unit test in the workshop, the load fail indicator light is always lit).

During commissioning, the following adjustment must be made:

- First of all, make sure that the thyristor unit is connected correctly and that the thyristors are in permanent firing mode.
- Turn the PLF detection adjustment potentiometer completely **anti-clockwise** and check that the "**Load Fail**" indicator light on the front fascia is off.
- Turn the "**Adjust/Seuil**" potentiometer slowly **clockwise** until the indicator light comes on.
- Turn the potentiometer slowly anti-clockwise until the "**Load Fail**" indicator light has just gone off.

The potentiometer adjusted in this way is used to obtain maximum sensitivity for the partial load failure detection really connected with the thyristor unit.

The push button on the front fascia (labelled "**Test**") which simulates a current drop of **10 %** in the load is used to check the operation of the PLF circuit without having to disconnect the load. This button must place the thyristor unit **in alarm status** if the adjustment has been performed correctly.

Reminder:

The PLF detection circuit does not use the load voltage, but the reference voltage.

CURRENT LIMIT ADJUSTMENT

Linear limit

The linear current limit can be adjusted using the "**I limit / Limit.I**" potentiometer on the front fascia.

- Make sure that the load is connected.
When used in conjunction with the threshold current limit (potentiometer or external signal), make sure first of all that the "Threshold limit" setpoint (terminal 5 "**I Limit I/P**" on the control terminal block) is at the maximum value.
- Turn the "**I limit / Limit. I**" linear current limit potentiometer completely **anti-clockwise (minimum current)**.
- At the input, apply a 0 V signal and connect the power voltage.
The RMS voltage at the load terminals must be zero.
- Increase the input signal to 100 %.
The load voltage must represent approximately **15 %** of the supply voltage.
- Turn the current limit potentiometer gradually clockwise and check that the current rises slowly.
Adjust the "**I limit / Limit. I**" potentiometer in order to obtain the maximum current **permitted** by the load.

Attention !



For the current limit adjustment, only use an ammeter which gives the **TRMS** value to measure the load current in order to prevent risks of errors which may reach 50 %.

For a **three-phase installation** using 2 or 3 TC1028 thyristor units, take care to turn each of the current limit potentiometers gradually in succession in order to maintain the balance of the currents in each phase.

Attention !



In the case of "Star with neutral" configuration, the neutral current for a load with a **high temperature coefficient**, when starting cold, can be **1.7 times greater** than the phase currents, limited by the current limit.
Redesign the installation as a consequence.

Threshold limit

The threshold current limit is independent of the control signal, it is one of the following:

- **110 %** of the thyristor unit nominal current (terminal **5** of the control terminal block directly connected to terminal **2**),
- controlled by an external potentiometer, of approximately **5 kΩ**, connected between terminal **2** (+ 10 V) and terminal **1** (0 V); the wiper is connected to terminal **5**,
- controlled by an external dc voltage (**0-10 V**).

The threshold "I Limit I/P" input impedance (terminal **5**) is greater than or equal to **150 kΩ** for the threshold current limit adjustment:

- After adjusting the linear limit (using the potentiometer on the front fascia), switch on the thyristor unit, set the control to maximum. Reduce the "Threshold current limit" setpoint gradually until the current starts to decrease.
- Mark the current limit setpoint corresponding to position **5** of the diagnostic unit and increase it by approximately **10%** so that it is only activated as a back-up for the linear current limit.

Attention !



The threshold current limit can be **pre-adjusted** when a thyristor unit is switched on but not firing.

The value of the **squared** RMS load current is **proportional** to the "Threshold current limit" setpoint observed at position **5** of the diagnostic unit.

Current limit signal (position 5 of the diagnostic unit)	I_{RMS}^2 (%)	I_{RMS} (%)
10 V	120	110
9.1 V	100	100
4.1 V	50	71

Table 6-5 Example of the threshold current limit

The **simultaneous** use of the two limits is possible:

- to set an absolute current limit with the threshold limit and
- to adjust the linear current limit with the potentiometer on the front fascia.

CHECKS IN THE EVENT OF ABNORMAL OPERATION

Symptom	Action
1. The thyristor unit is not fired after a firing demand	<p>1.1. Check that the "Enable" input (terminal 9 on the driver board) is connected to "+10 V" (terminal 2).</p> <p>1.2. Check that the control signal arrives correctly on the driver board user terminal block:</p> <ul style="list-style-type: none">• on terminal 7 with the external control• on terminal 6 in manual control. <p>1.3. Check that the input signal type and level are compatible with the type and level of the configured signal.</p> <p>1.4. Check the cabling of the thermal switches on the power board</p> <p>1.5. Check the presence of the thyristor firing pulses:</p> <ul style="list-style-type: none">• pulses at 20 V for Phase angle firing• pulses at 26 V in Burst firing mode in position 13 of the diagnostic unit. <p>1.6. Check that the power limit is not at zero (position 5 of the diagnostic unit) and that the setpoint is present (external input in position 4 or manual input in position 2)</p> <p>1.7. Check that the supply voltage is greater than or equal to 80% of the thyristor unit nominal voltage.</p>

Symptom

Action

2. The transient over-current during the inductive load start is too high.

2.1. Check that the load cabling is correct.

2.2. Check the level of the oscillator input signal (signal in position 15 of the diagnostic unit is 6.4 V peak; for measurement, use an oscilloscope).

2.3. The pre-adjustment at 90° (in the factory) of the firing delay angle has not been readjusted.

Decrease this angle slightly by turning the "Delay" potentiometer on the front fascia of the thyristor unit anti-clockwise.

See "Preliminary adjustment of the inductive load", page 6-11.

If the fault persists after all these checks, contact your nearest EURO THERM office, where technicians will be able to advise you and assist you during commissioning.

Chapter 7

MAINTENANCE

Contents	Page
Thyristor protection	7-2
Thyristor protection fuse	7-3
Fuse blown indication micro-switch	7-4
Protection fuses for reference voltage connection	7-5
Servicing	7-5
Tools	7-6

Chapter 7 MAINTENANCE

Danger !



The unit must be maintained by qualified personnel only

THYRISTOR PROTECTION

The thyristors of the TC1028 series power units are protected as follows:

- the internal high speed fuse against over-currents
- the RC snubber and the varistor against too fast voltage variations and transient over-voltages when the thyristors are not firing
- the thermal switch (in the event of accidental overheating of the cooler the thermal switch opens, which causes the thyristor firing to be stopped).

THYRISTOR PROTECTION FUSE

The standard version of TC1028 series units is supplied with the high speed fuse mounted on the line busbar.

Attention !



High speed fuses are only used for the internal protection **of thyristors** against wide amplitude over-loads.

This high speed fuse may under no circumstances be used to **protect the installation**.



Danger !

The user's installation **must be protected upstream** (non-high speed fuse, thermal or electromagnetic circuit breaker, suitable fuse-isolator) and comply with current standards.

Table 7-1 contains all the references of the original internal fuses (when the thyristor unit leaves the factory) and the fuse which can be used for replacements during maintenance.

Maximum line-to-line voltage: **480 V**.

Nominal current		Part No.		
Th. unit (A)	Fuse (A)	EUROTHERM	FERRAZ	BUSSMANN
300	400	LA172468U400	H300065	170M5458
400	500	LA172468U500	K300067	170M5460
500	630	LA172468U630	M300069	170M5462

Table 7-1 Recommended high speed fuses for thyristor protection



The use of any fuses **other** than those recommended for thyristor protection **invalidates the thyristor unit guarantee**.

FUSE BLOWN INDICATION MICRO-SWITCH

As an option, high speed fuses may be equipped with a fuse blown indication micro-switch (**FUMS** option) with the part No.:

for **BUSSMANN** fuses:

EUROTHERM DC172267 or FERRAZ P96015 or **BUSSMANN** 170H0069

for **FERRAZ** fuses:

EUROTHERM DC172997 or **FERRAZ** G310 000

To ensure improved insulation between the cabling of the micro-switches and the power and the cover, TC1028 power thyristor units are supplied with three "flag" type lugs and insulating sleeves.

Each external terminal of the fuse blown indication micro-switch must be cabled with a "flag" lug and an insulating sleeve in compliance with figure 7-1.

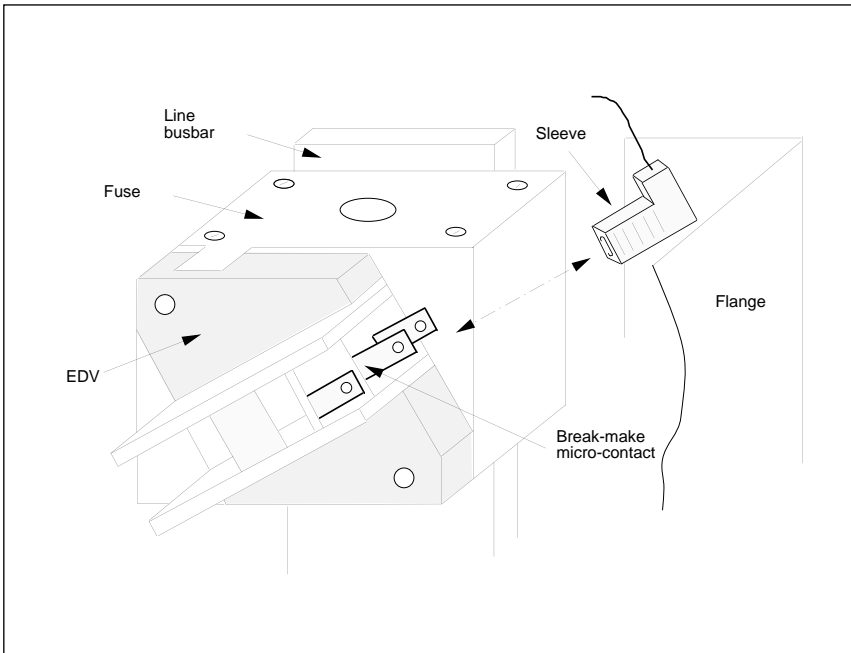

Figure 7-1 Use of "flag" lugs and insulating sleeves to observe insulating distances.

PROTECTION FUSES FOR REFERENCE VOLTAGE CONNECTION

These fuses must be installed in the connection wires of the reference voltage (see "Cabling" chapter).

Reference voltage (max)	1 A fuse 6.3 x 32 mm	Fuse-isolator support	Overall "Fuse-isolator" dimensions (mm)
480 V	CS174289U1A0	CP174293	63 x 15 x 52

Table 7-2 Recommended protection fuse for the reference voltage connection

SERVICING

TC1028 thyristor units must be mounted with the heatsink positioned vertically and with no obstructions either above or below which could block the passage of the ventilation air.



Attention !

If multiple units are installed in the same cabinet, they should be arranged in such a way that the air expelled by one unit **cannot be admitted** into the unit located above it.

In order to ensure correct cooling of the unit, users are advised to **clean the heatsink and the protective grill** of the fans regularly according to the degree of environmental pollution.



Danger !

Every **six months**, check that the screws of the power cables and safety earth are **tightened correctly** (see "Cabling", page 3-3).

TOOLS

Operation	Flat screw-driver (mm)	Wrench	Electrical equipment
Fixing		Depending on M8 screw heads selected	
Opening (closing) of front door		CHc No. 4 for M5 screw	
Safety earth connection		HEX19 (M12)	
Power connection (supply side) and thyristor fuse change		HEX17 (M10)	
Load connection		HEX19 (M12)	
Cable clamp tightening	0.5 x 3.5		
Control and reference voltage connection	0.5 x 3.5		
Board fixing	0.8 x 5.5	For M4 nut	
Commissioning and calibration	0.4 x 2.5		Ammeter or RMS clip. Eurotherm type 260 diagnostic unit recommended

Table 7-3 Tools