

# ULTRA SLIMPAK® II MODEL WV438-2000

## Potentiometer Input Isolating Signal Conditioner

### Installation and Calibration Instructions

**NOTE:** The unit has been shipped with the Power Clips attached. Please remove the clips before installing the module on the DIN rail. If the Power Clips are chosen as the means to route power, they can be installed once the modules are in place on the DIN rail.

#### DIN Rail Mounting

The WV438 mounts on a 35mm TS35 DIN rail, by simply hooking one side of the mounting foot over the rail and pressing the module towards the rail until it locks into place. To remove the unit from the rail, place the tip of a flat-bladed screwdriver under the release clip on either the top or the bottom of the module and pry up until the module releases from the rail. See Figure 1.

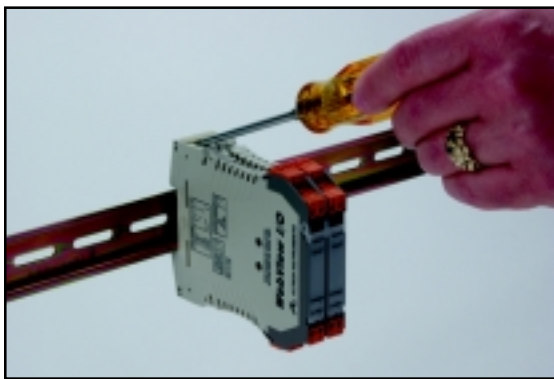

Figure 1

the front side of the upper and lower terminal blocks for a positive fit. The board slides in where the switch and the switch position chart on the case can be viewed together.

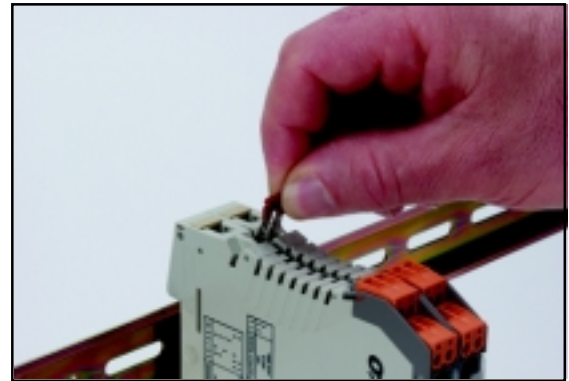

Figure 2

#### Wiring Connections

Pin	Description
11	Potentiometer Input (full CW)
12	Potentiometer Input (full CCW)
21	DC Power (+)
22	DC Power (-)
41	Potentiometer Input (wiper)
42	Shield Ground
51	Output (+)
52	Output (-)

#### Input Range Configuration

Unless otherwise specified, the factory presets the Model WV438 as follows:

Input: Potentiometer  
Range: 100 ohms to 100k ohms  
Output: Current  
Range: 4-20mA  
Reverse Out: Off  
Remote Cal: Off

1. For other ranges, refer to the SWITCH SETTINGS table. Reconfigure switch S1 for the desired output type and range.
2. Set position 1 of S1 to ON if a WVC16 will be utilized and remote calibration capability is desired.
3. Set position 2 and 3 of S1 for the desired output type.
4. Set position 4 of S1 to ON for reverse output operation.

#### Power Connections

The power jumper clips (see Figure 2) are used to distribute power to a maximum of 16 modules. In applications using more than 16 modules, power wiring must be connected to the first and last module, and distributed to the remaining modules using the power clips. This technique allows for "hot swapping" of a module without interrupting power to the remaining units.

#### Opening the Case

The case can be opened by simultaneously pressing in on the two ribbed tabs located at the top and bottom of the front cap of the case and sliding out the circuit board. This provides easy access to the DIP switch for range selection. To close the case, slide the board back in until the two tabs lock firmly in place. This may require pressing on

## Switch Settings

Function	S1			
	1	2	3	4
Remote Cal Enable	■	-	-	-
<b>Output Range</b>				
0 to 10V	-	■	■	-
0 to 20mA	-		■	-
4 to 20mA	-			-
Reverse Out	-	-	-	■

Key: ■ = 1 = ON or Closed; - = n/a

## Diagnostic LEDs

Other than when executing the pushbutton calibration routine, the LEDs blink under the following conditions:

<b>GREEN:</b>	Flashes at 2Hz when the input is under range. Flashes at 8Hz when the input is over range.
<b>RED:</b>	Flashes at 2Hz when the output is under range. Flashes at 8Hz when the output is over range.

An Under Range condition exists when the signal is lower than the operation low value minus 6.25% of operational span. An Over Range condition exists when the signal is higher than the operation high value plus 6.25% of operational span.

A voltage output short circuit can cause an under range condition (RED blinking at 2Hz rate). A current output open circuit can cause an over range condition (RED blinking at an 8Hz rate).

There could be two or more LEDs blinking at the same time, which means the module has more than one error condition. Only when all error conditions have been removed will the LEDs be back to normal (green on, red and yellow off).

## Calibration

For best results, calibration should be performed in the operating environment, mounted to a piece of DIN rail, allowing at least one hour for thermal equilibrium of the system. If pre-calibration on a test bench is desired, then an output load equal to the input impedance of the devices connected to the WV438 output is recommended, along with the warm-up period.

Note: Many applications do not require calibrating the output levels and simply utilize the default operational output ranges of the unit (0-10VDC, 0-20mA or 4-20mA). If the factory default calibration has been changed, the last saved operational output values are utilized. In those applications, the only calibration required is the operational

input values. Once the maximum and minimum input values have been set, the Green and Red LEDs will be on. At that point simply press the CAL button rapidly 3 times and you will exit the calibration routine without effecting the last saved calibration for the operational output values.

1. Connect the input to a potentiometer of the same value to be used in operation and the output to a voltage or current meter. Apply power and allow the system to reach thermal equilibrium. Refer to Figure 3 for a detailed flow chart of the procedure. The section in the dotted-line box is all that is required for the user to calibrate operational input and output, and is all that is described in this procedure.

2. Adjust the input signal to the desired maximum and observe that the Green LED is on or flashing. Push the CAL button and hold for more than 4 seconds. The Yellow and Red LEDs should be on. Push the CAL button momentarily and the Yellow and Green LEDs will be on. From this point on, you can exit the calibration procedure at any step, without saving new data, by holding the CAL button for at least 4 seconds.

3. Apply the maximum input signal level desired and push the CAL button. The Yellow LED should now be on.

4. Apply the minimum input signal level desired and push the CAL button. The Green and Red LEDs should now be on. If you do not wish to change the output calibration, press the CAL button rapidly three times to exit the calibration routine.

5. Adjust the input signal upward until the output is at the desired maximum level (e.g. 20.00mA), and then push the CAL button. The Red LED should be on.

6. Adjust the input signal level downward until the output is at the desired minimum level (e.g. 4.00mA), and then push the CAL button. All three LEDs should now be on.

7. Push the CAL button once more to save the calibration data. The Green LED should be on if the input is within the calibrated range.

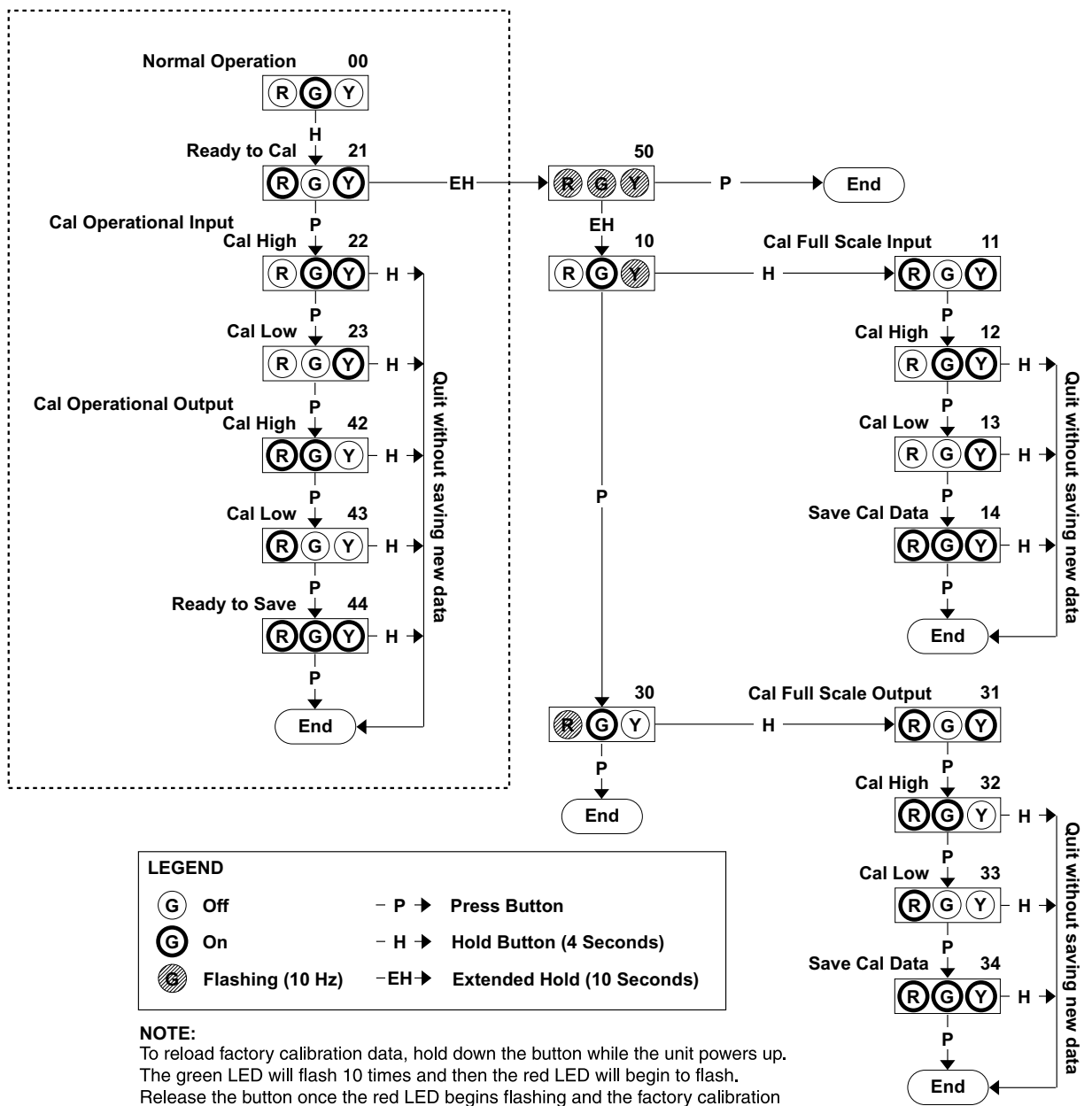

LEGEND	
(G) Off	- P → Press Button
(G) On	- H → Hold Button (4 Seconds)
(G) Flashing (10 Hz)	- EH → Extended Hold (10 Seconds)

**NOTE:**  
 To reload factory calibration data, hold down the button while the unit powers up. The green LED will flash 10 times and then the red LED will begin to flash. Release the button once the red LED begins flashing and the factory calibration data will be reloaded.

Figure 3: WV438 Calibration Flowchart

## Specifications

### Potentiometer Resistance (end to end)

100 ohms (min) to 100k ohms (max)

### Input Ranges

Pushbutton adjustable

Effective zero offset:  $\geq 95\%$

Effective span turndown:  $\geq 95\%$

### Input Impedance

> 1M ohms

### Linearity

$\pm 0.1\%$  of span, typical

### Excitation

300mV, nominal

### Turn-Up/Turn-Down

80% (90% to  $\pm 0.2\%$  linearity)

### Common Mode Rejection

60Hz: >100dB

DC: >120dB

### Output Ranges

0-10VDC,

0-20mA, 4-20mA

### Response Time

100mSec typical

### Stability

$\pm 100$ ppm of span/ $^{\circ}$ C

### Output Ripple

0.2% of span, or 5mVrms, whichever is greater

### Output Impedance

Voltage Output: <10 ohms

Current Output: >100k  $\Omega$

### Output Drive

Voltage Output: 10mA, max

Current Output: 20V compliance @ 20mA (1k ohms, max)

### Power

9 to 30VDC

1W typical, 2W maximum

### Isolation

Input to Output to Power: 1800VDC

### Size

DIN rail case – 0.5" wide (12.7mm), refer to Dimensions drawing

### Environmental

Operating Temperature:  $0^{\circ}$ C to  $+60^{\circ}$ C ( $32^{\circ}$ F to  $140^{\circ}$ F)

Storage Temperature:  $-25^{\circ}$ C to  $+85^{\circ}$ C ( $-13^{\circ}$ F to  $185^{\circ}$ F)

Operating Relative Humidity (non-condensing): 15% to 95%RH at  $45^{\circ}$ C

Non-operating Relative Humidity: 90%RH at  $60^{\circ}$ C for 24 hours

### Agency Approvals

CUL

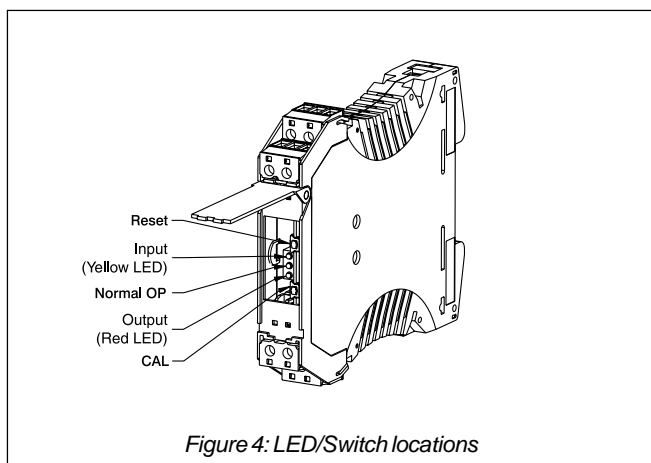

## Dimensions

Dimensions are in mm (inches)

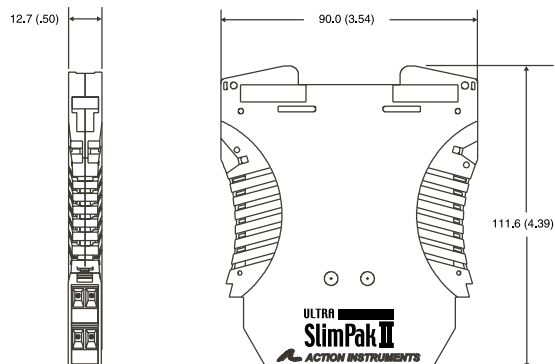

Eurotherm Controls

741-F Miller Drive

Leesburg, VA 20175-8993

703-443-0000

info@eurotherm.com

## Factory Assistance

For additional information on calibration, operation and installation contact our Technical Services Group:

**703-669-1318**

actionsupport@eurotherm.com

HA136738WV438 Rev - Copyright © Eurotherm, Inc 2004